



TREKHAKEN • ATTELAGES • ANHÄNGERVORRICHTUNGEN • TOWBARS • ENHANCES • ANHÆNGERTRÆK • GANCI DI TRAINO

Montagehandleiding | instructions de montage | Einbauanleitung | Mounting instruction  
Instrucciones de montaje | monteringsvejledning | istruzioni di montaggio



## BYD Dolphin

08/'21-

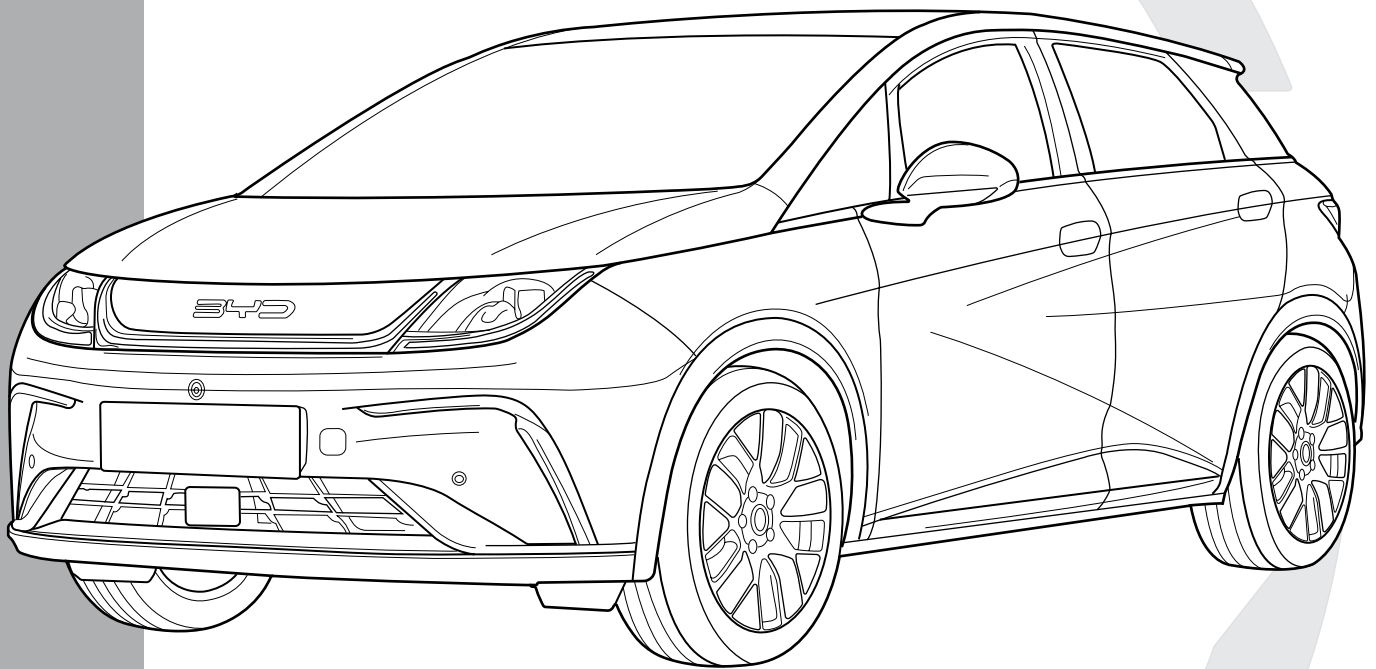

# NO TOWING

*Montage*

- Voor de montage moet de fietsdragerconstructie eerst op het voertuig gepresenteerd worden.

De belasting van een accessoire dat op de koppelingskogel wordt voorzien is anders van aard. Voor deze accessoires kunnen verschillende limieten van toepassing zijn. Hiervoor verwijzen we naar het instructieboekje van de wagen of naar uw concessiehouder.

*Montage*

- Présenter la construction porte-vélos sous le véhicule avant d'effectuer le montage.

La charge d'une accessoire prévue sur la boule d'attelage, est de nature diverse. Pour les accessoires, il peut y avoir des limites d'utilisation différentes. Nous vous recommandons de vous référer à votre livret d'instructions ou de vous renseigner chez votre concessionnaire.

*Fitting*

- Present the bike carrier construction under the car first to check if all points are right.

The load of an accessory fitted on the towing ball is of a different nature. Different limits may apply. For this matter, we refer to the instruction manual of the vehicle or we advise you to contact your concessionaire.

*Montage*

- Erst die Konstruktion für Fahrradträger und das Fahrzeug kontrollieren, danach montieren.

Die Belastung eines Zubehörs, die man auf einer Kupplungskugel voraussieht, ist wesentlich anders. Für die Zubehöre geldet, dass diese unterschiedlich begrenzt sein können. Deswegen möchten wir verweisen auf die Bedienungsanleitung des Fahrzeugs oder auf Ihren Vertragshändler.

*Montaje*

- Presentar la construcción para portabicicletas debajo del vehículo antes de realizar el montaje.

La carga de un accesorio montado en una bola de remolque son de una naturaleza diferente. Se pueden aplicar diferentes límites a ambos. Para este asunto, nos referimos al manual de instrucciones del vehículo o le recomendamos que contacte a su distribuidor.

*Montering*

- Præsenter konstruktionen til cykelholdere under bilen først for at kontrollere, om alle punkter er rigtige.



Belastningen af tilbehør tilkoblet anhængertrækket er forskellige. Der kan være forskellige begrænsninger på begge. I disse tilfælde henviser vi til bilens manual, eller anbefaler dig at kontakte bilforhandleren

*Montaggio*

- In primo luogo, presentare la struttura sotto l'automobile per verificare che tutti i punti di attacco coincidano.

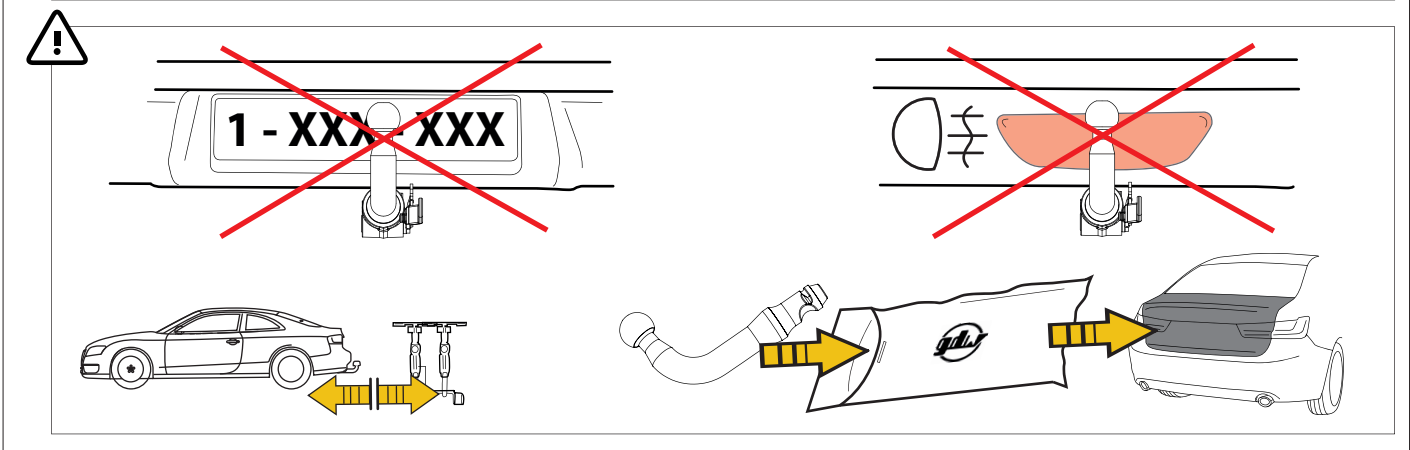
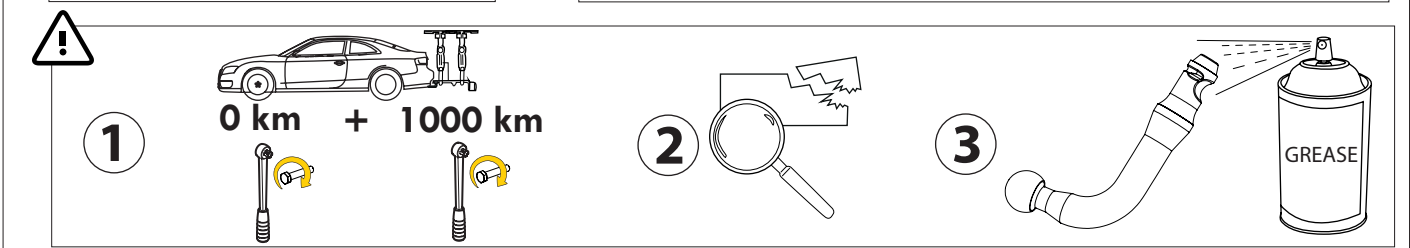
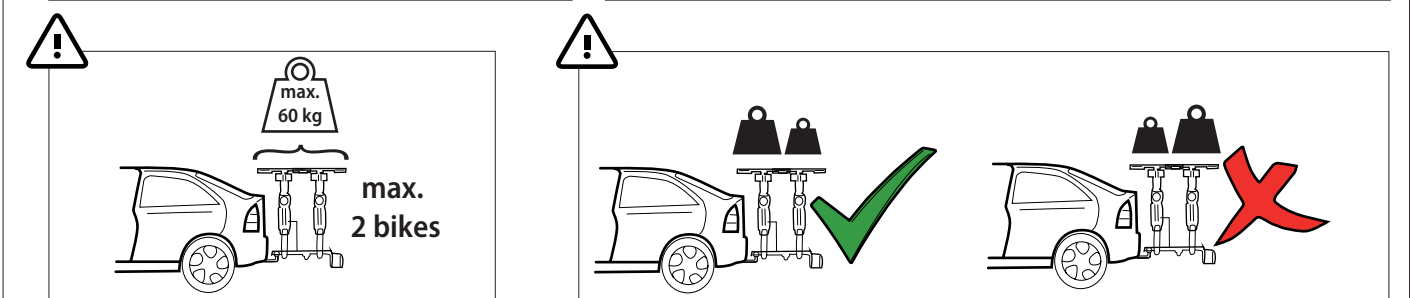
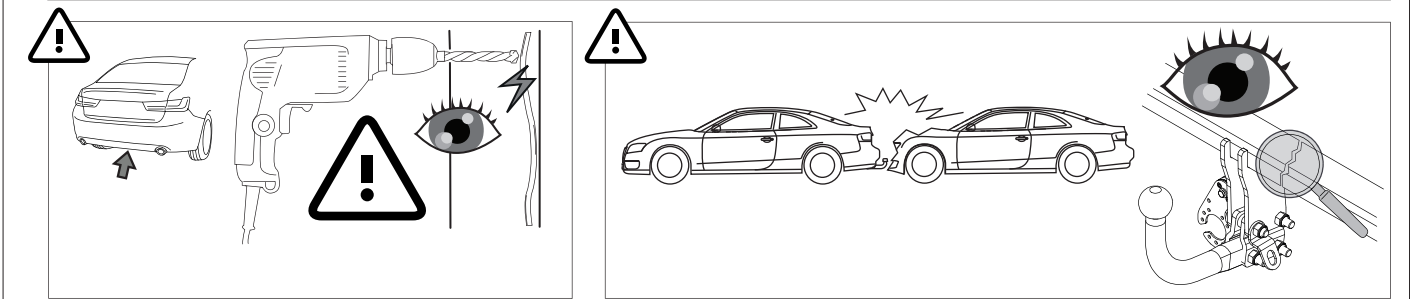
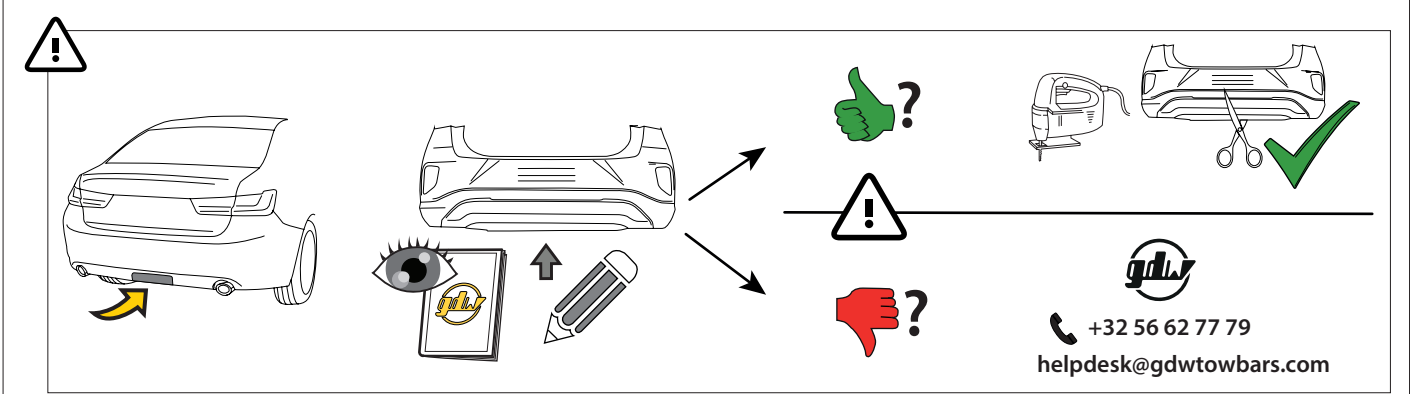
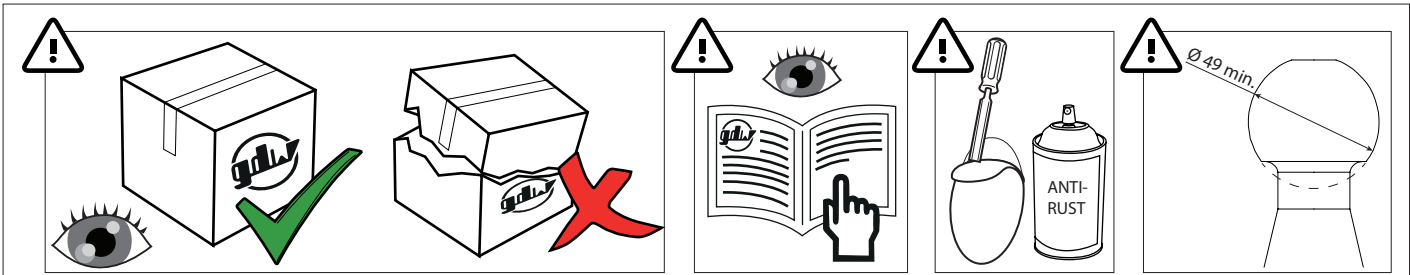
La massa rimorchiabile del veicolo potrebbe essere diversa dal valore riportato sul documento del gancio di traino. Per questo motivo, vi invitiamo a consultare sempre la carta di circolazione del veicolo (Pos. O.1) o a rivolgervi alla vostro concessionario di fiducia



MADE BY  

BELGIUM **NO TOWING** D 0,00

REF N° SERIAL N°

2817T60 xxx S 75

DISCRIPTION

BYD Dolphin 08/'21-

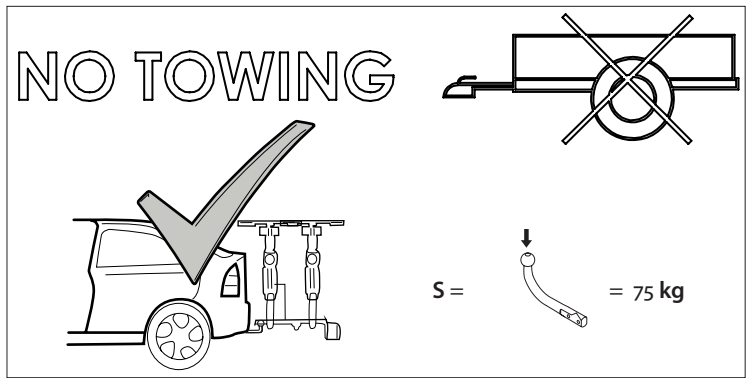

 See the Certificate Of Conformity (COC) of your vehicle or contact your dealer to verify the max. trailer weight of your car!

 See the user manual of the vehicle for correct use of bicycle carriers!

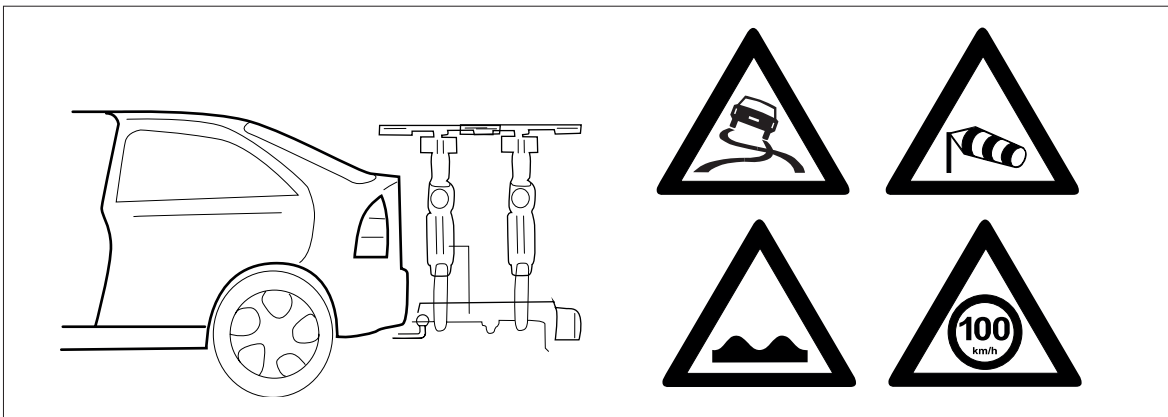
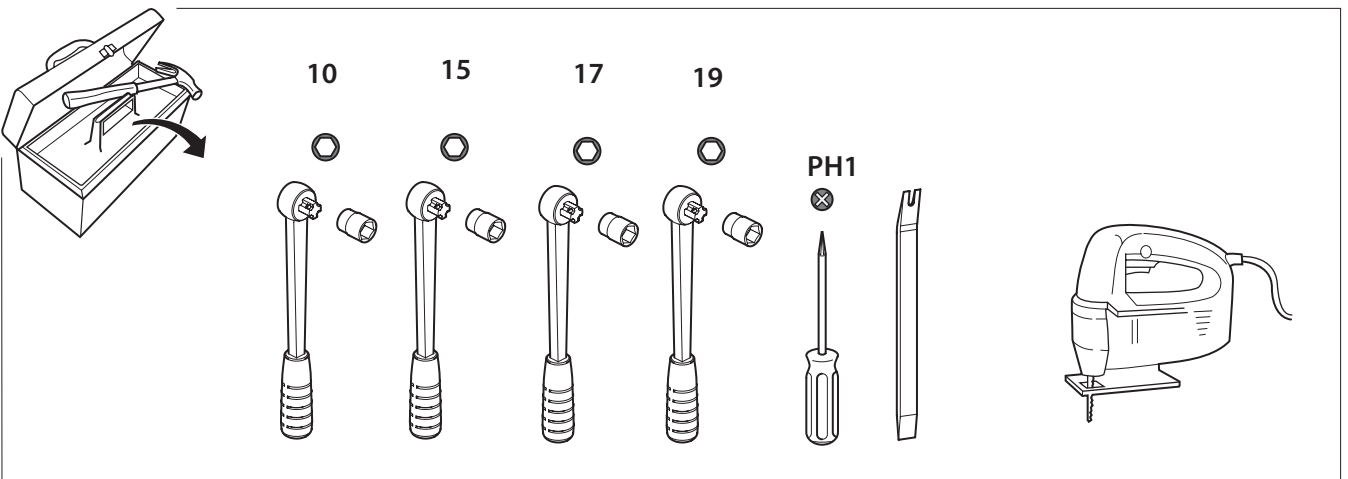

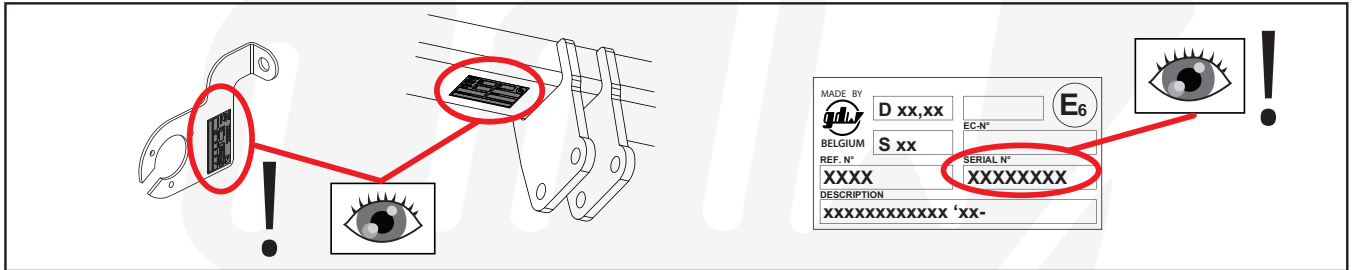







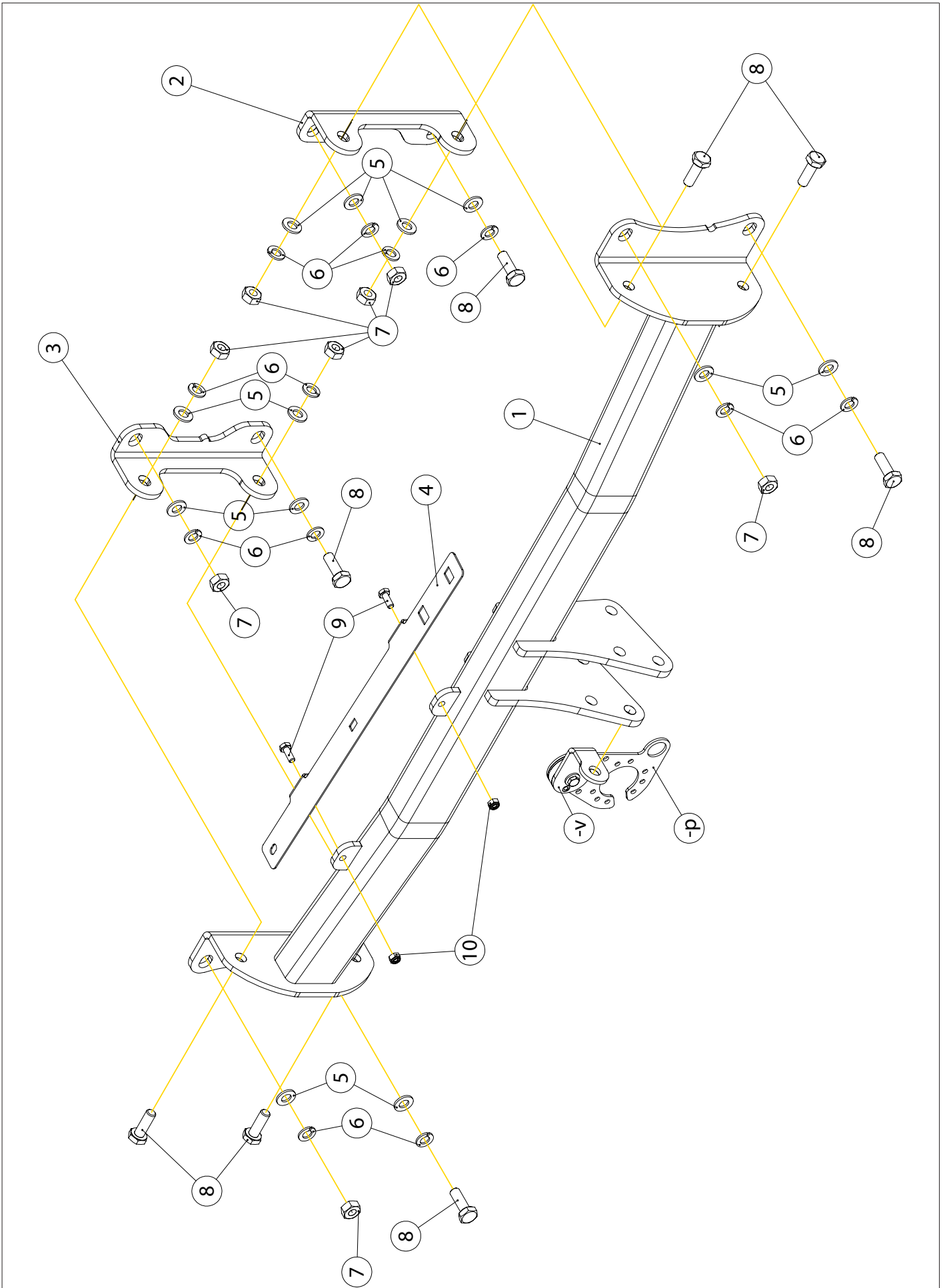

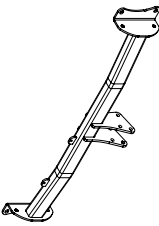
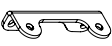







**helpdesk@gdwtowbars.com**  
**+32 56 62 77 79**







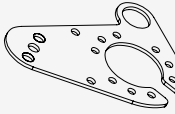

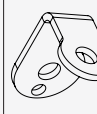

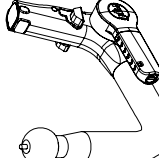
Monday	08:00 - 12:00	12:30 - 16:30
Tuesday	08:00 - 12:00	12:30 - 16:30
Wednesday	08:00 - 12:00	12:30 - 16:30
Thursday	08:00 - 12:00	12:30 - 16:30
Friday	08:00 - 12:00	12:30 - 15:30

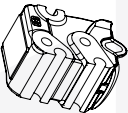
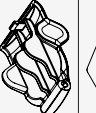

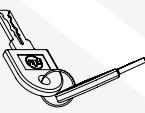

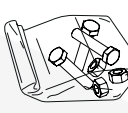
1		X1	GDW REF. 2817T60
2		X1	GDW REF. 2
3		X1	GDW REF. 3
4		X1	GDW REF. 4
5		X12	DIN 125A-10.5X20X2
6		X12	GROWER VSK-M10
7		X8	DIN 934-M10X1.25
8		X8	DIN 961-M10X30X1.25
9		X2	DIN 933-M6X16
10		X2	DIN 985-M6
-V		X1	GDW REF.908.096

-P		X1	GDW REF. P40
↳		X1	DIN985-M6
↳		X2	6,2 X 15,4 X 1,6 (NYLON)
↳		X1	GDW REF. 718.16.002
↳		X1	GDW REF. 718.16.003
↳		X1	GDW REF. 908.094
↳		X1	DIN933-M6 X 30
↳		X1	GDW REF. 908.096

Geleverd met - Livré avec - Delivered with Geliefert mit - Elementos adjuntos-Leveres med		X1	GDW REF. 960.V0810T
↳		X1	GDW REF. 740.200
↳		X1	GDW REF. 912.003
↳		X1	GDW REF. 740.112
↳		X1	GDW REF. 740.111
↳		X1	GDW REF. 740.12X X= LAST NUMBER ON KEY
↳		X1	GDW REF. 718.15.001
↳		X1	GDW REF. SYST60-10
↳		X3	DIN931-M12X110-8.8
↳		X3	DIN128A-M12
↳		X6	DIN125A-M12
↳		X3	DIN934-M12

1

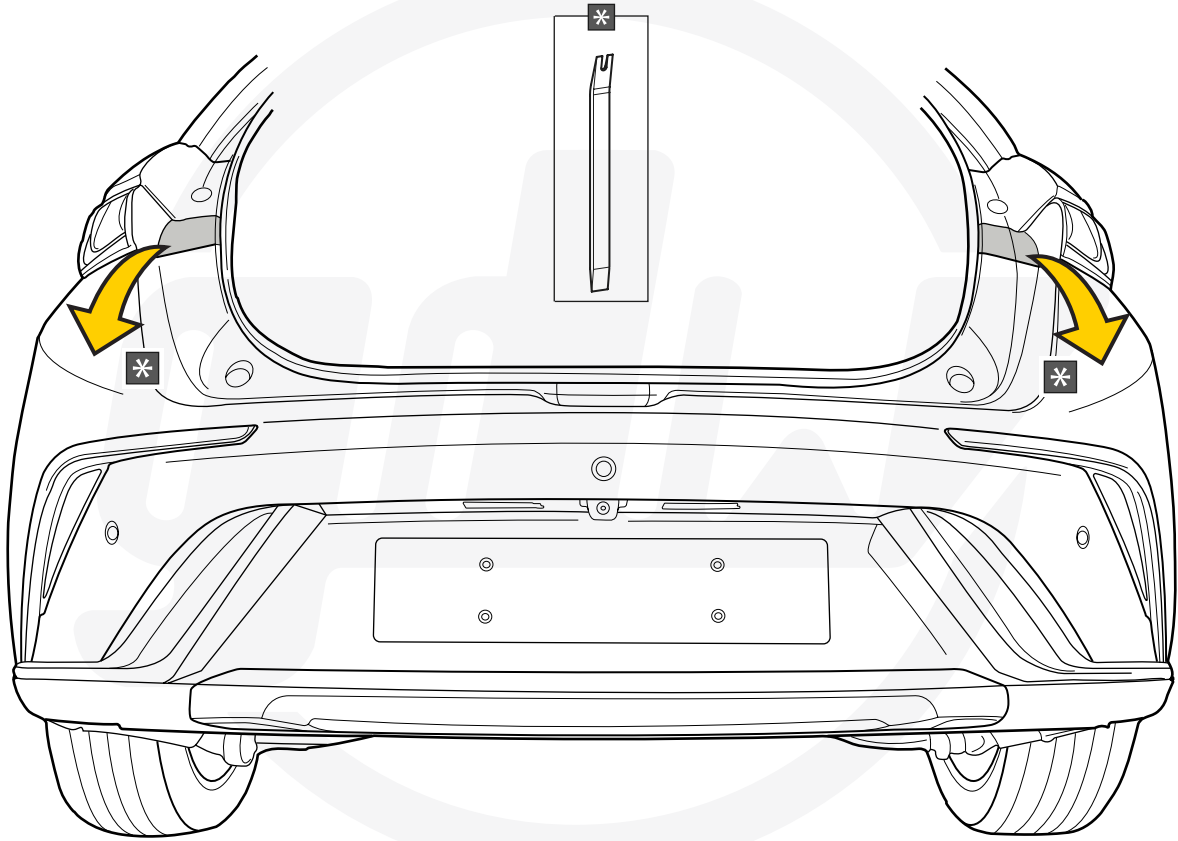

2

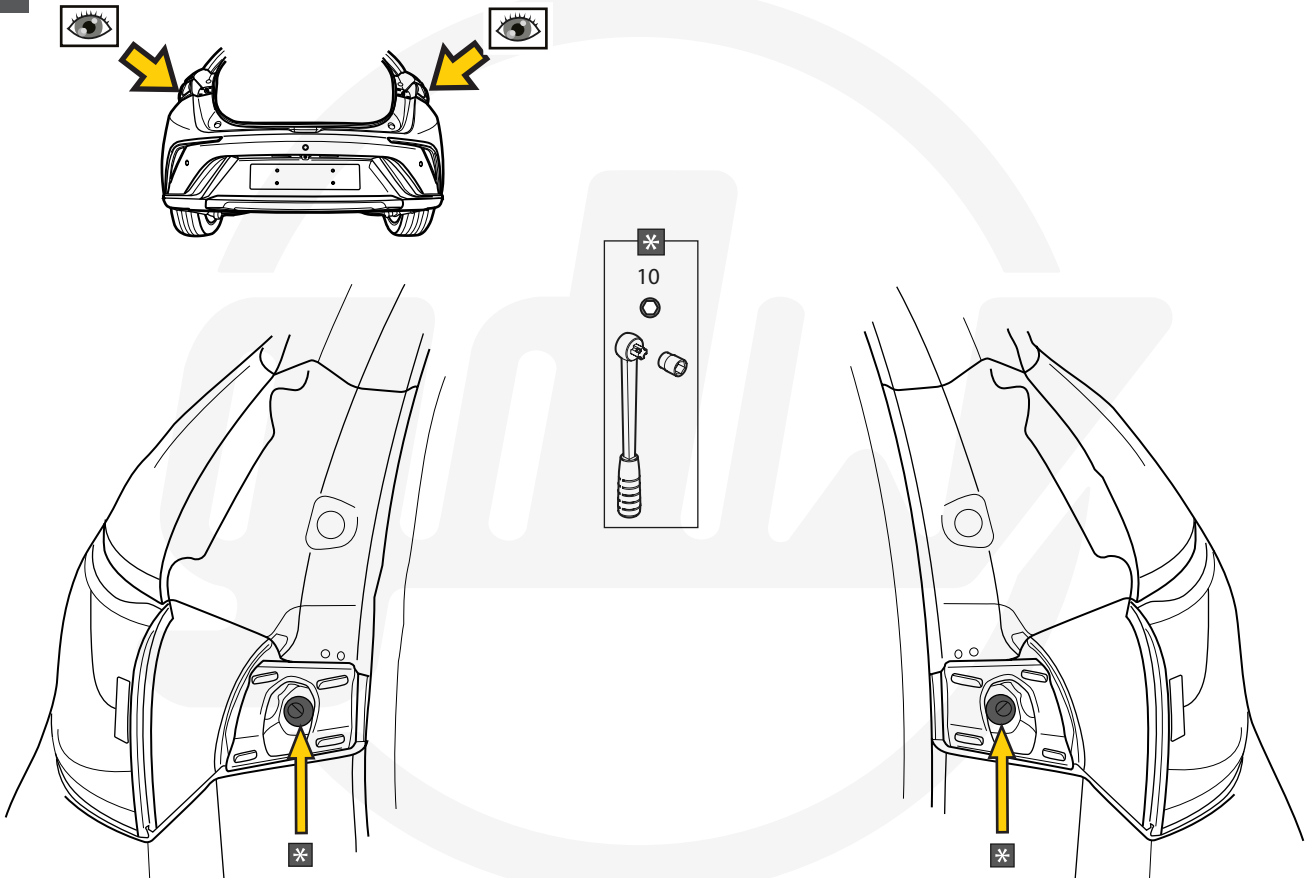

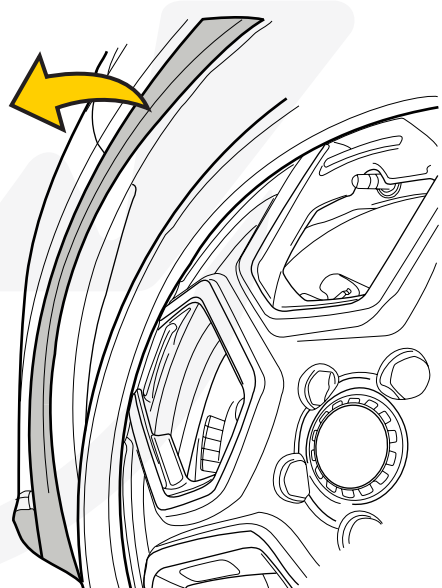
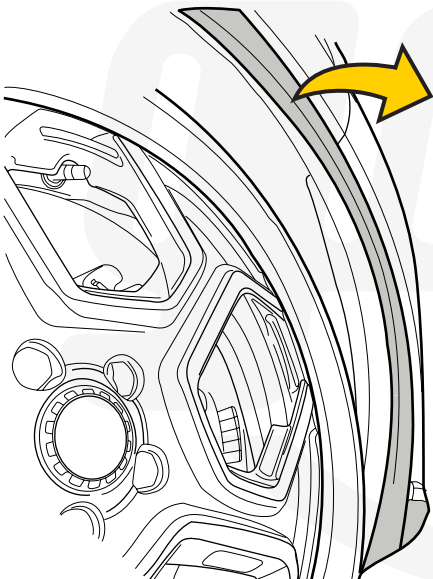
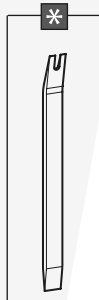
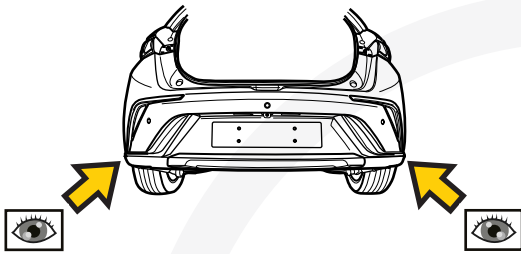
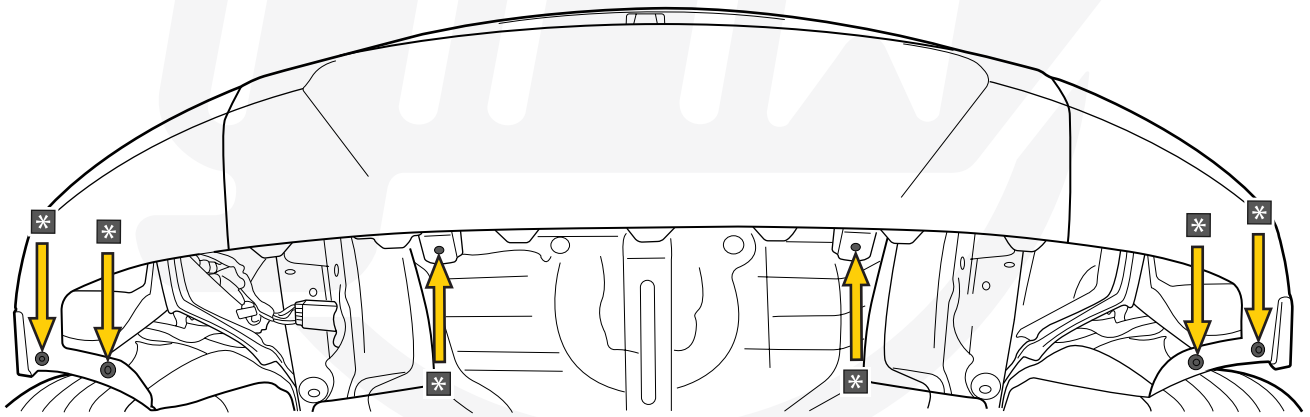
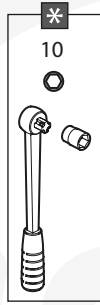
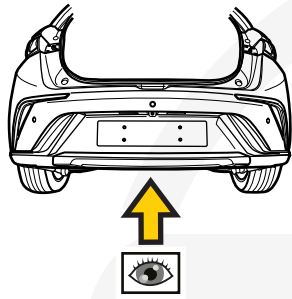

5

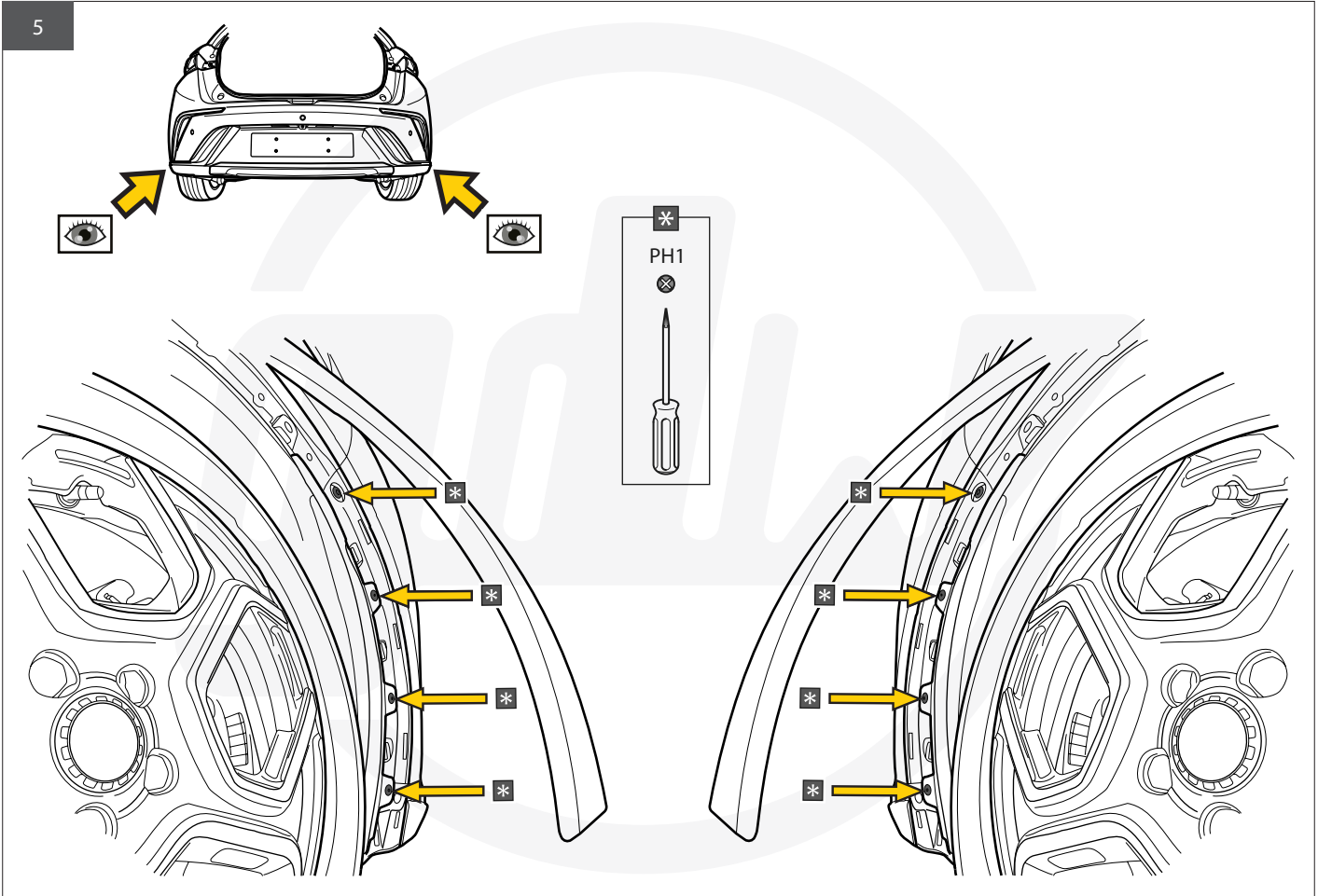

6

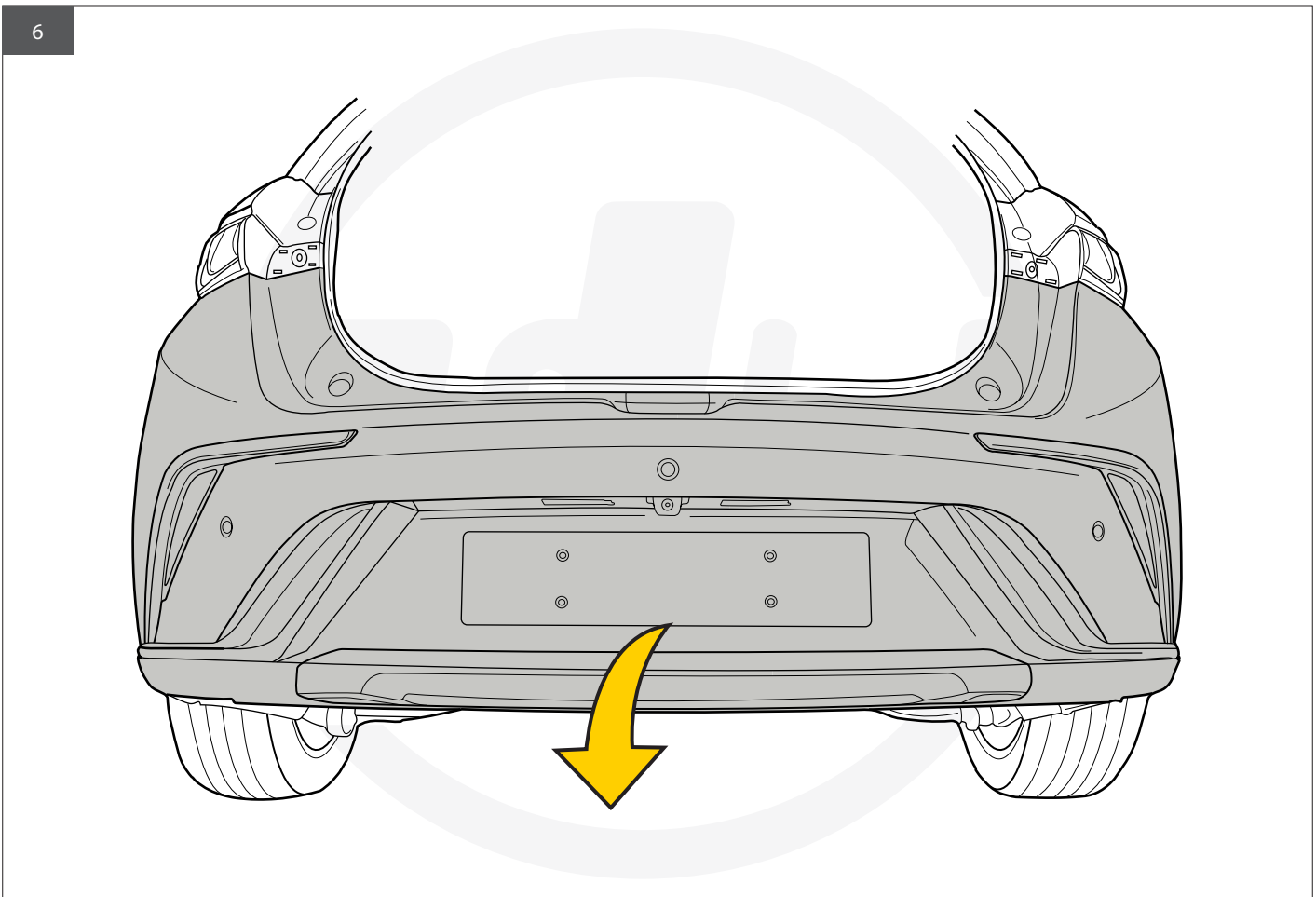

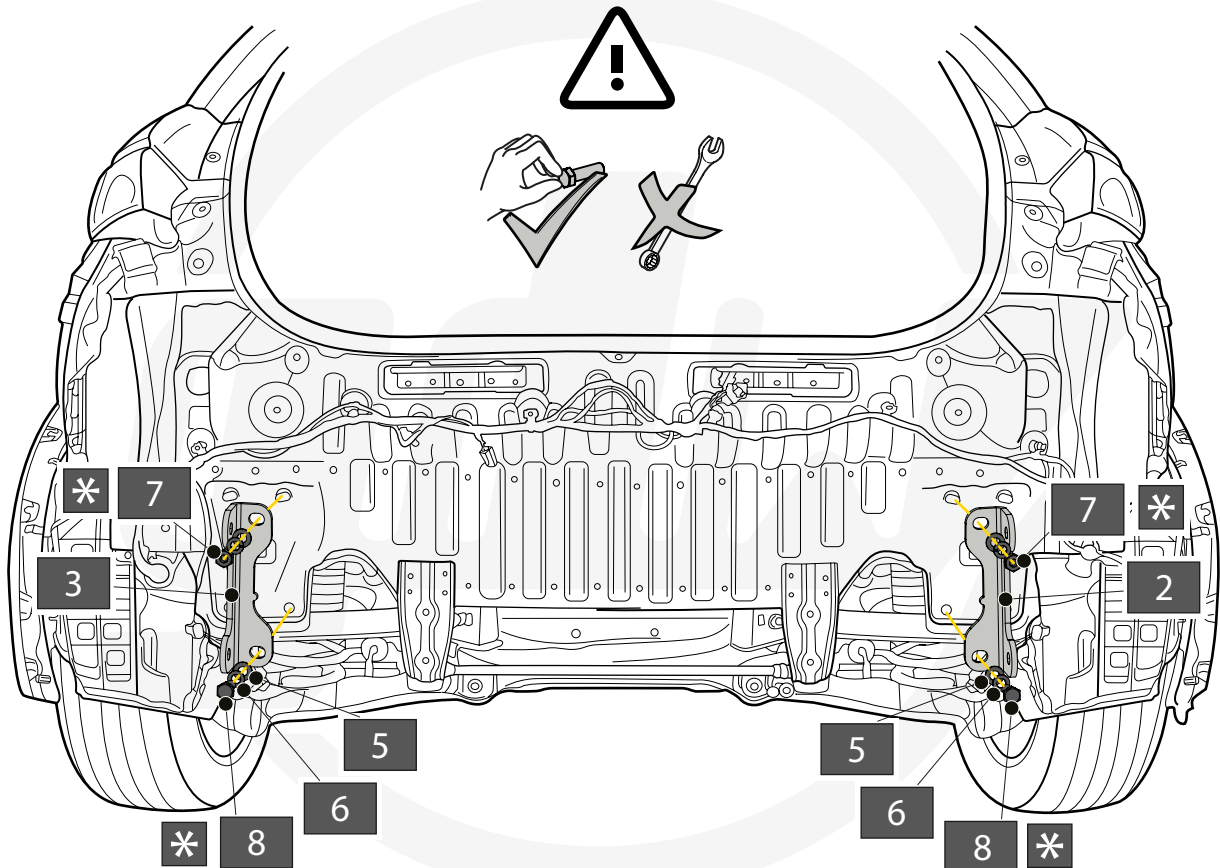
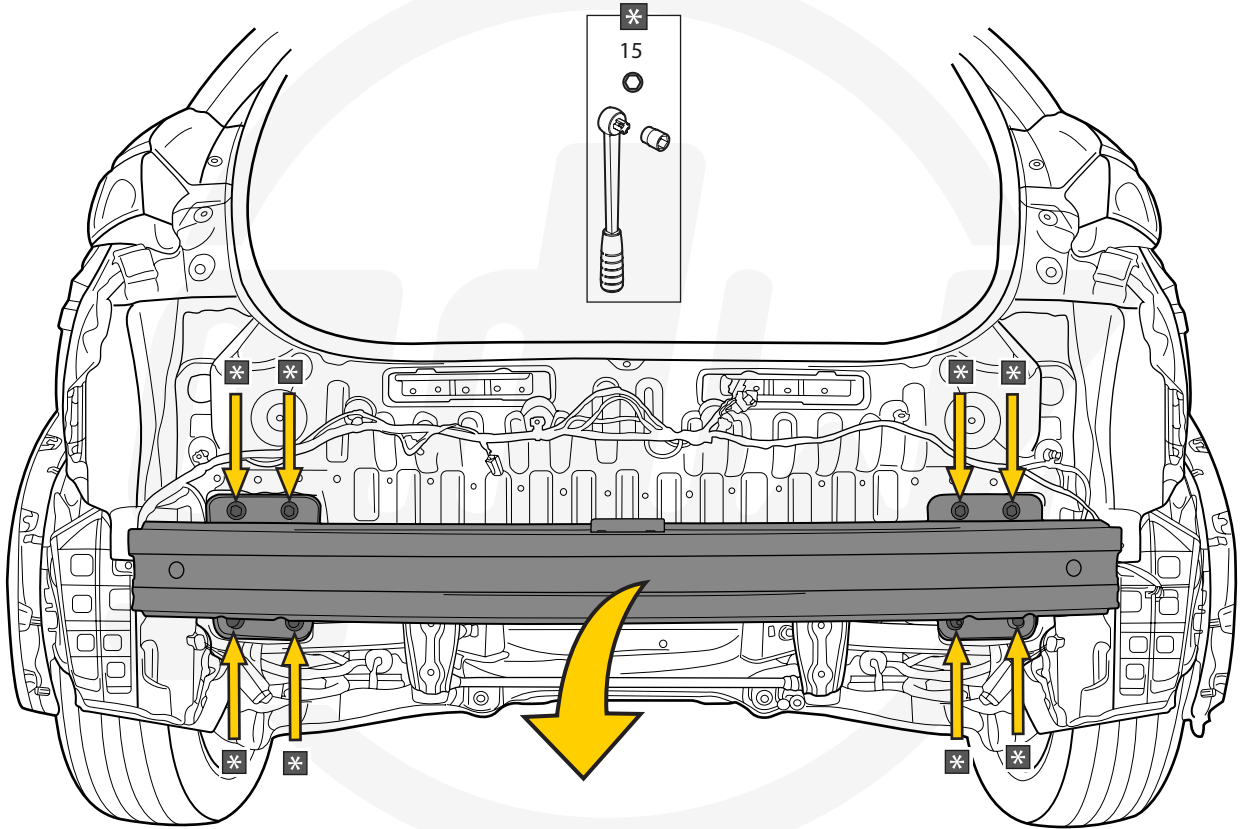

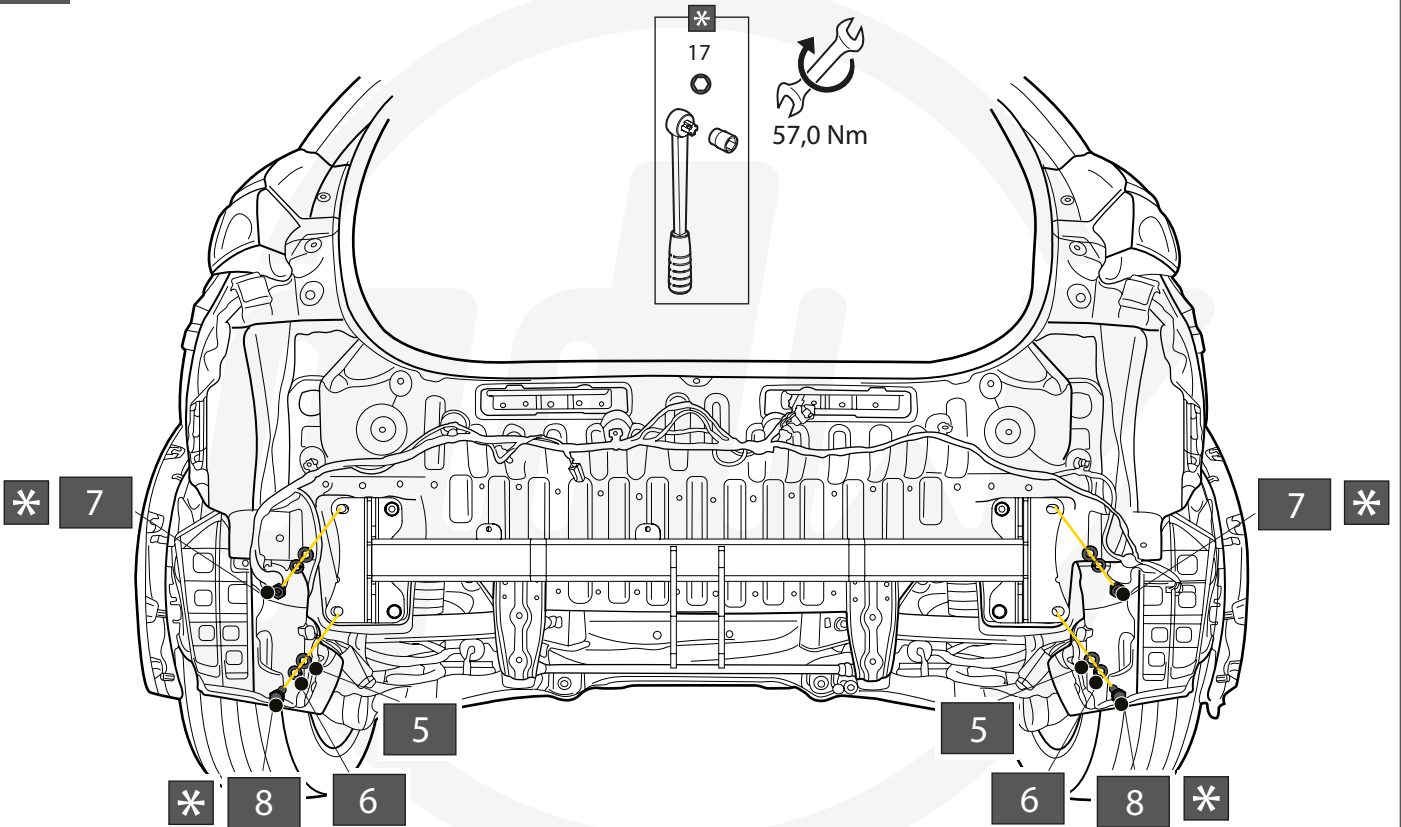
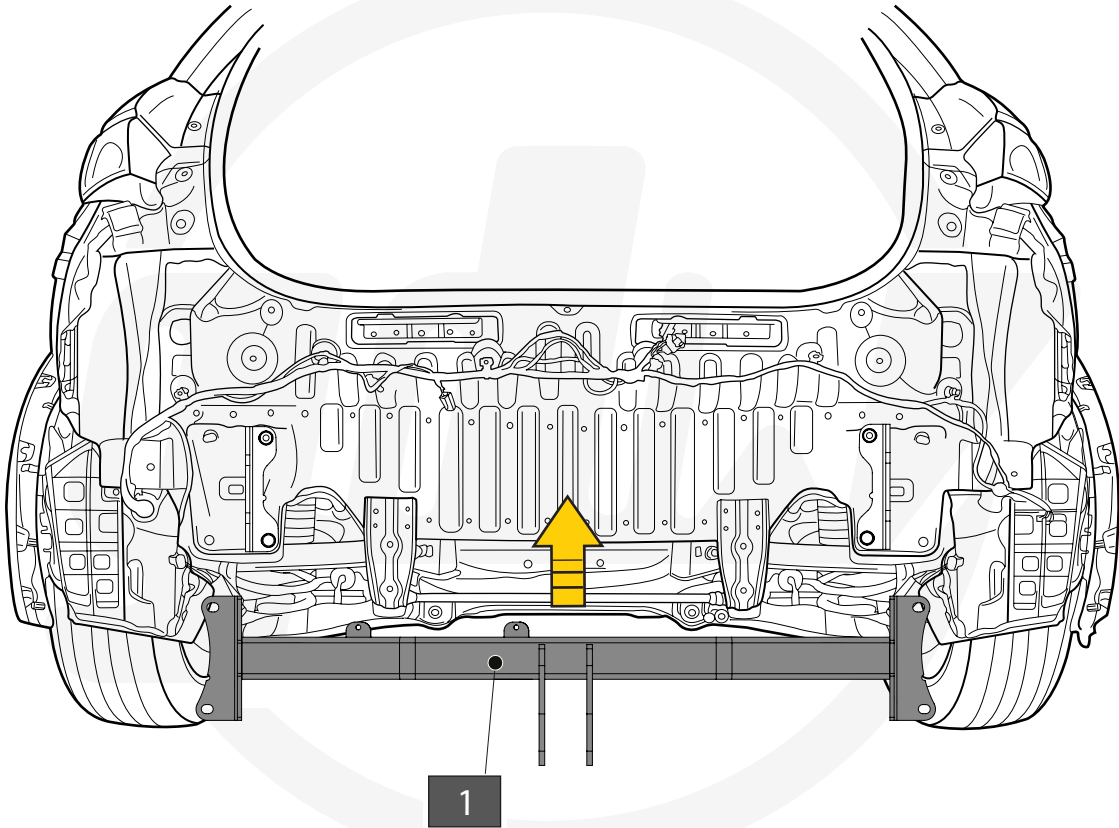

11

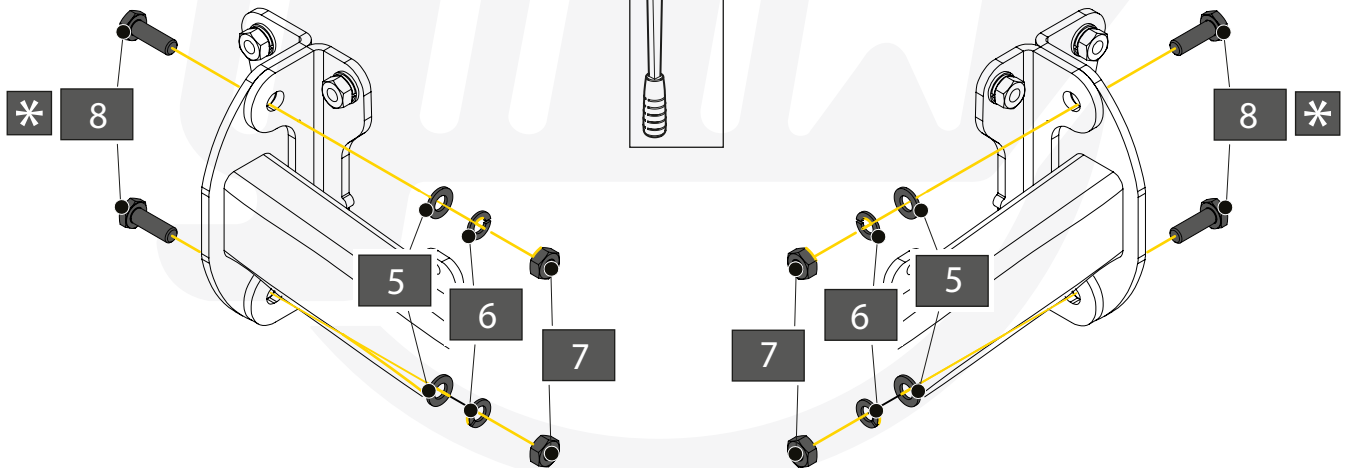
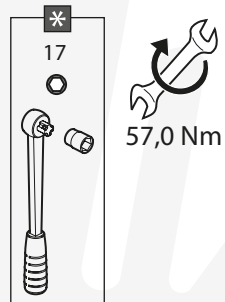
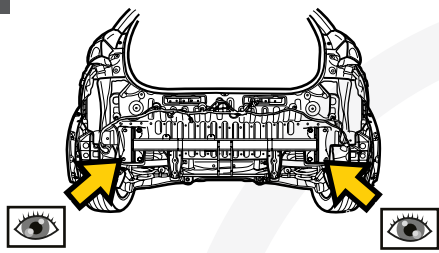

12

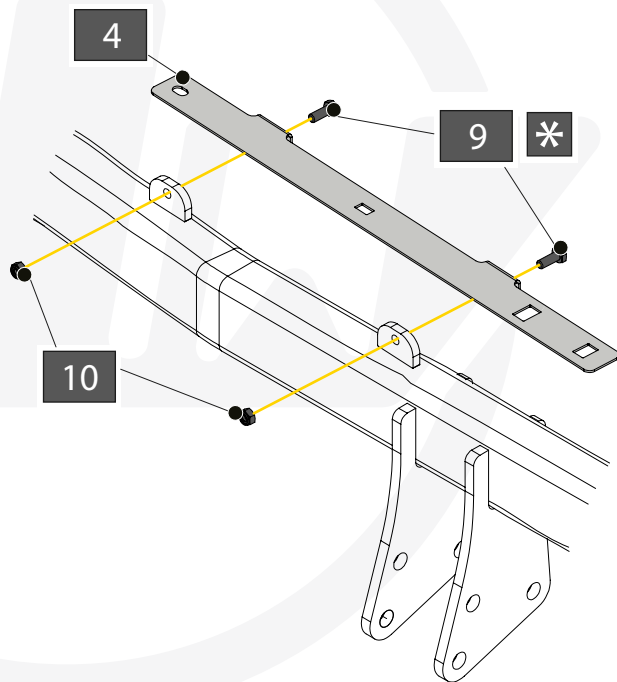
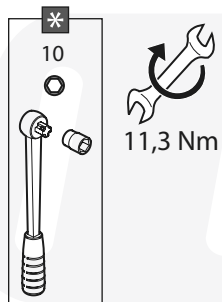
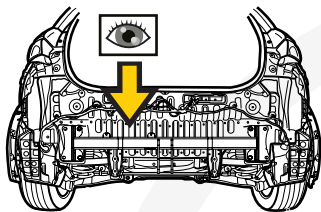

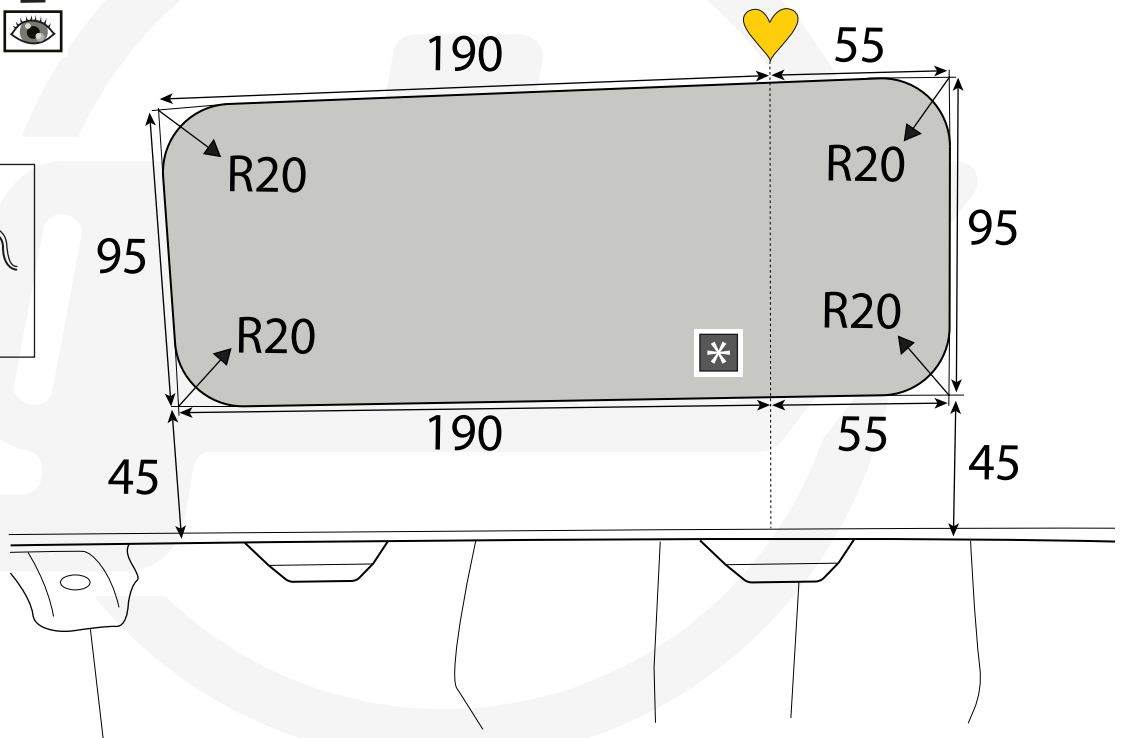
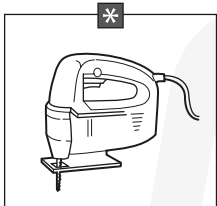
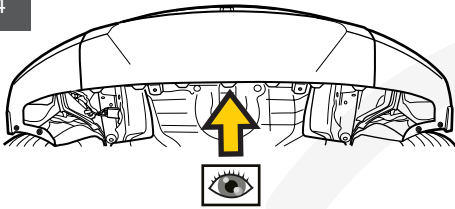
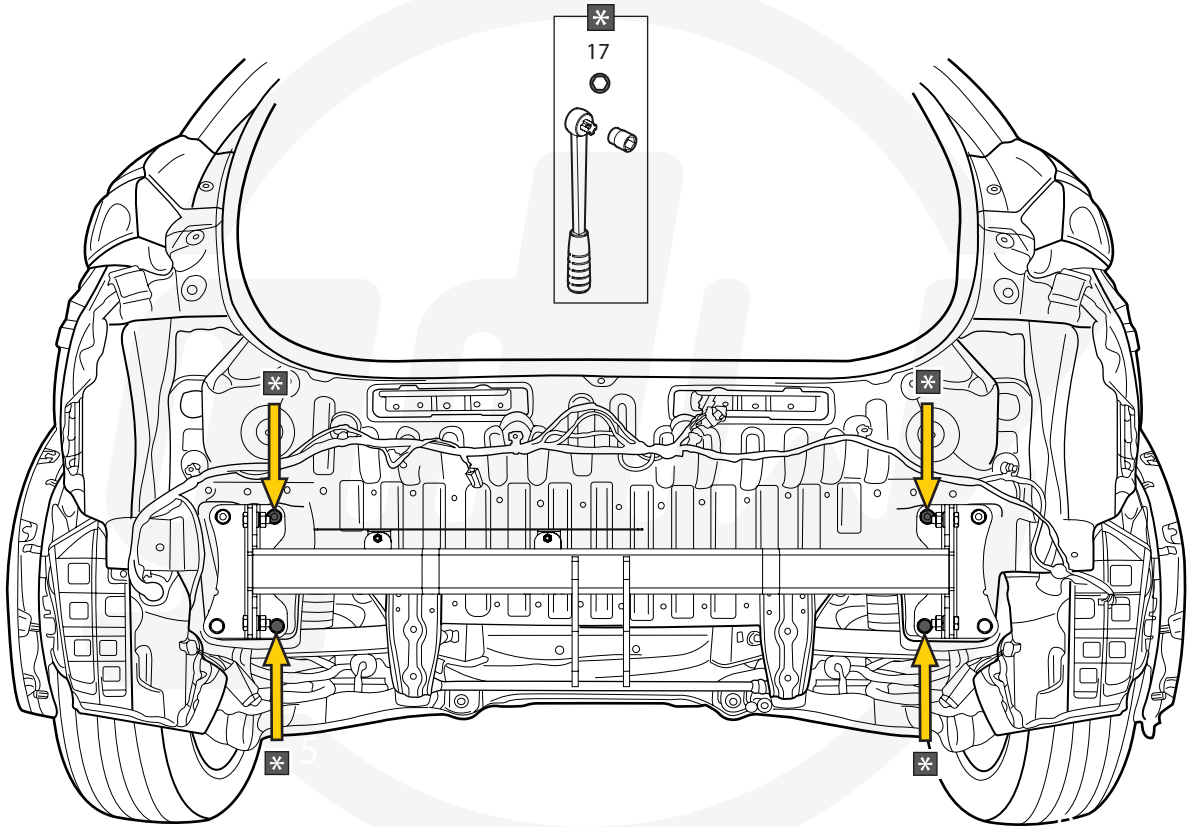

A		X1	GDW REF. 908.096
B		X1	DIN985-M6
C		X2	Ø15,4 X 6,2 X 1,6 (NYLON)
D		X1	GDW REF. 718.16.002
E		X1	GDW REF. 718.16.003
F		X1	GDW REF. 908.094
G		X1	DIN933-M6 X 30

A		X1	912.003
B		X3	DIN931-M12X110
C		X3	DIN128A-M12
D		X6	DIN125A-M12
E		X3	DIN934-M12

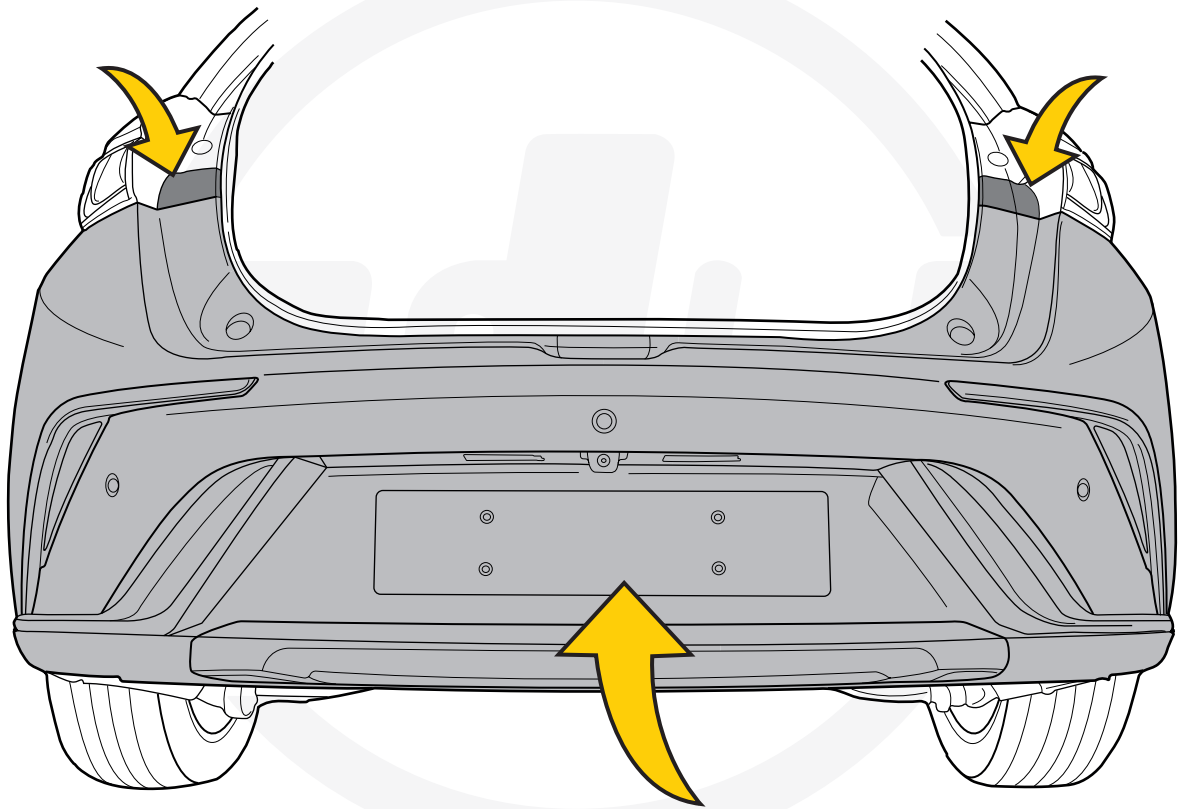

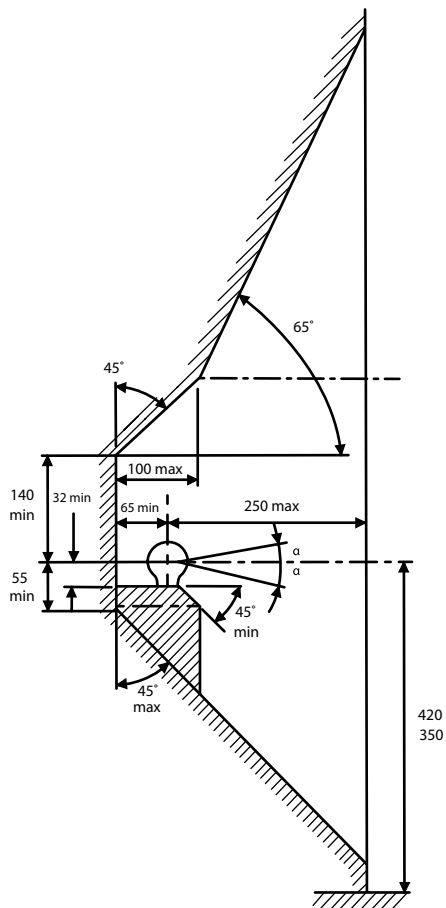

De tussenruimte conform bijlage VII, afbeelding 25 (a, b) van het reglement R55 UN/ECE moet in acht genomen worden. Deze voorschriften zijn niet van toepassing op terreinvoertuigen klasse G.

La zone de dégagement doit être garantie conformément à l'annexe VII, illustration 25 (a, b) de la règle R55 UN/ECE. Ces dispositions ne s'appliquent pas aux véhicules tout-terrain classe G.

The clearance specified in appendix VII, diagram 25 (a, b) of regulation R55 UN/ECE must be guaranteed. These requirements shall not apply to all-terrain vehicles class G.

Der Freiraum nach Anhang VII, Abbildung 25 (a, b) der Regulierung R55 UN/ECE ist zu gewährleisten. Diese Vorschriften gelten nicht für Geländefahrzeuge Klasse G.

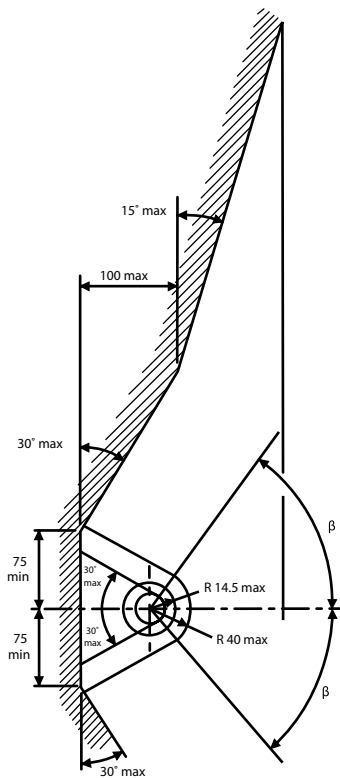

Bij toelaatbaar gewicht van het voertuig

Pour poids total en charge autorisé du véhicule

At laden weight of the vehicle

Bei zulässigem Gesamtgewicht des Fahrzeuges

Peso total admisible del vehículo

Ved tilladt samlet vægt for køretøjet

Peso totale ammissibile del veicolo