

Peugeot 308 (2022-)
Opel Astra (2022-)

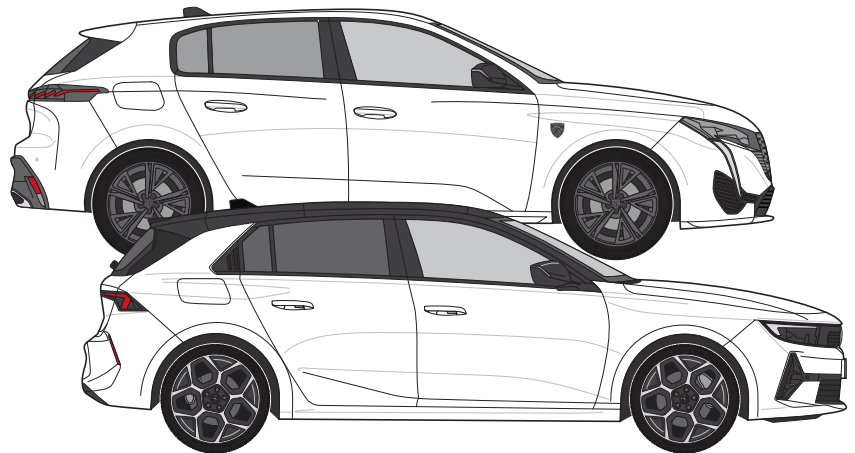

R55

Peugeot 308 (2022-)
Opel Astra (2022-)

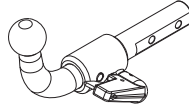

TowCar **aragon** enganches

E13 APPROVALNUMBER D D-VALUE
55R-02 4811 D 9,5 kN

TYPE CLASS MAX.VERT.LOAD
PEU053 A50-X S 115 kg

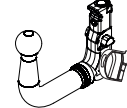

TowCar **aragon** enganches

E13 APPROVALNUMBER D D-VALUE
55R-02 4812 D 9,5 kN

TYPE CLASS MAX.VERT.LOAD
PEU054 A50-X S 115 kg

D=9,5 kN



S= 115 kg

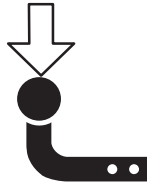

*T 1600 Kg



N/m	8,8	10,9	12,9
M6	10	15	18
M8	24	36	42
M10	51	75	87
M12	87	130	147
M14	138	198	231
M16	200	289	341

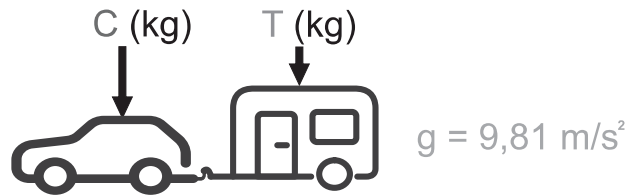







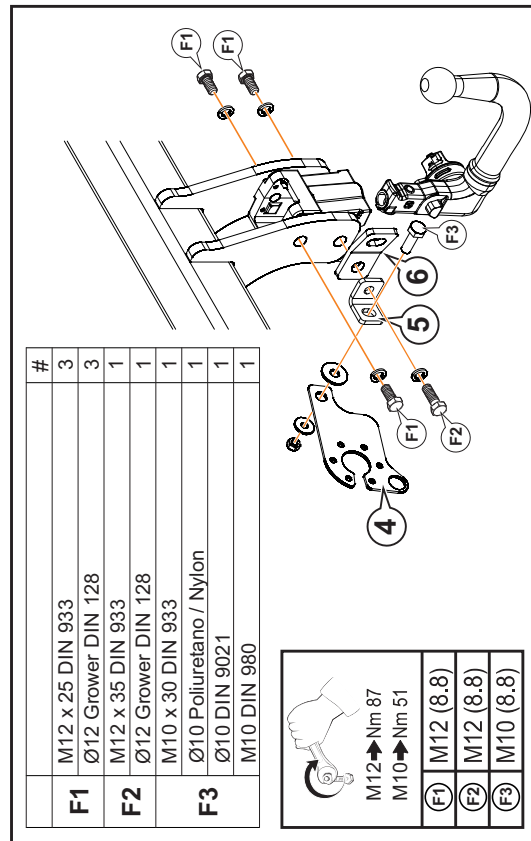
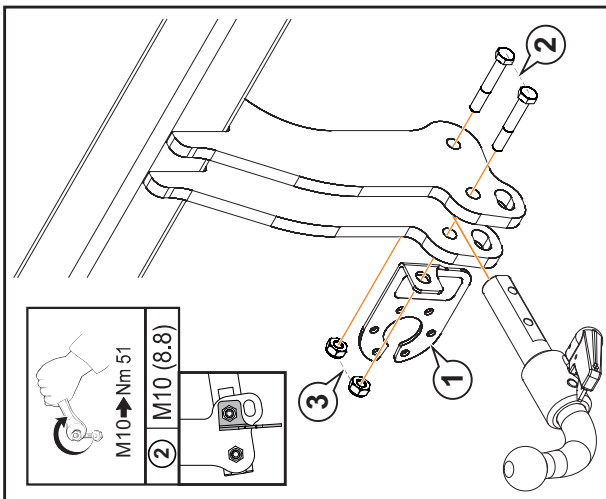
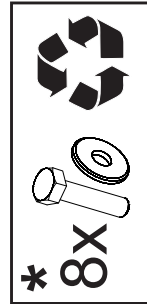
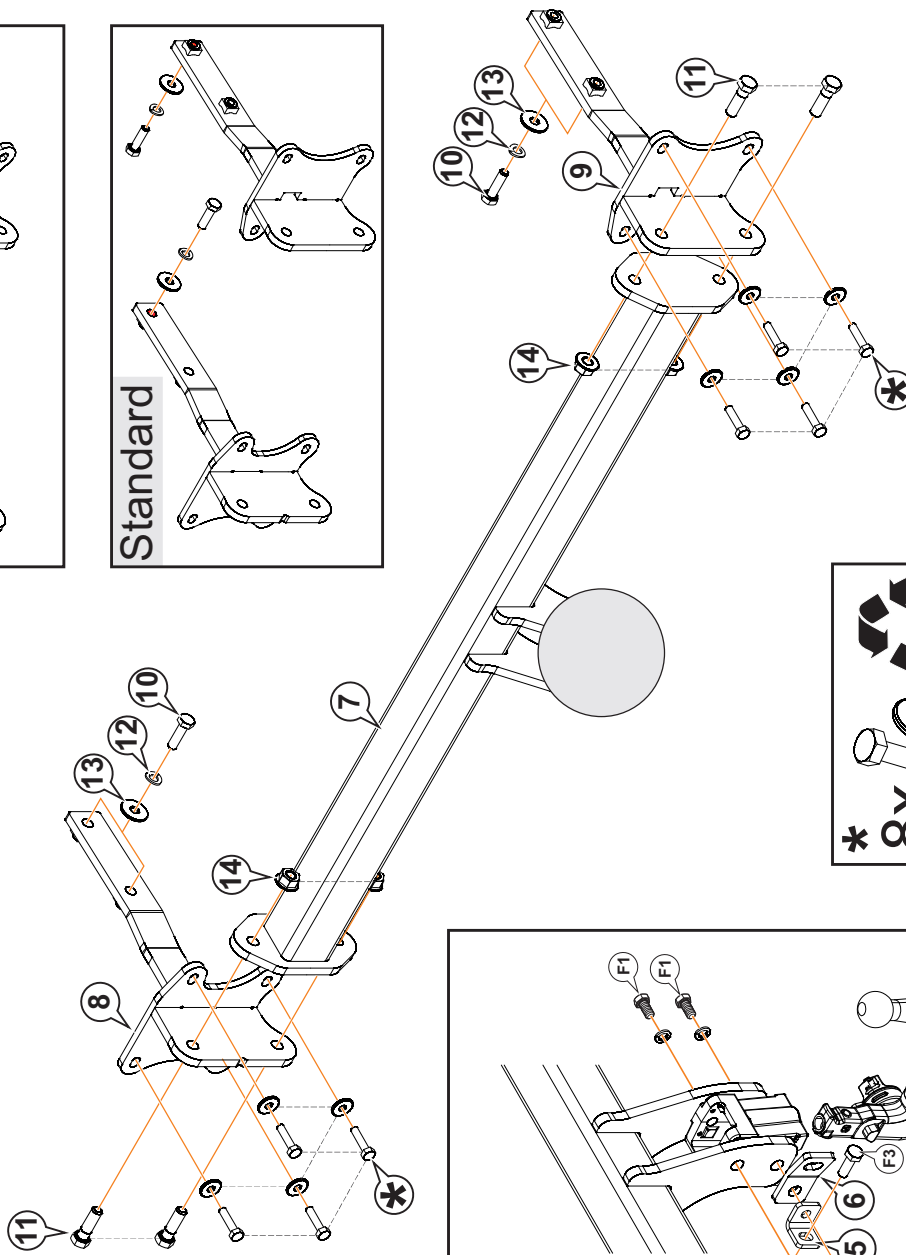
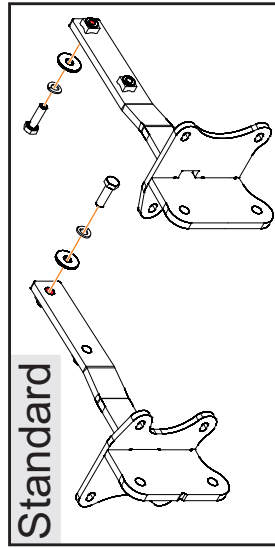
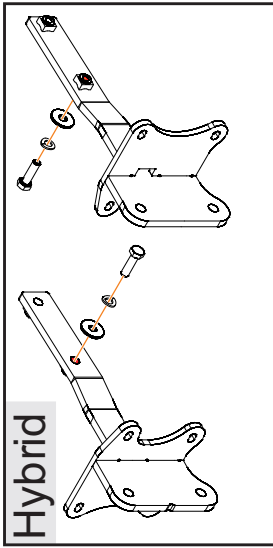

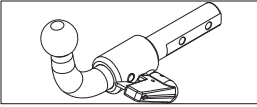
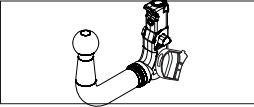





$$D \geq \frac{T \cdot C}{T+C} \cdot \frac{g}{1000} \text{ (kN)}$$

$$T \leq \frac{C \cdot D \cdot 1000}{(C \cdot g) - (1000 \cdot D)} \text{ (kg)}$$

*El MMR (T) puede variar dependiendo del vehículo.



				
1		AEV0005	1	
2		M10x65 DIN 931 (8.8)	2	
3		M10 DIN 980	2	
4		AEV0009		1
5		AEV0008		1
6		AEV0006		1
7		C4716CX60	1	1
8		C4716CV62	1	1
9		C4716CV61	1	1
10		M10x35 DIN 933 (8.8)	2	2
11		M12x40 DIN 933 (8.8)	4	4
12		Ø10 DIN 128A	2	2
13		Ø10 DIN 9021	2	2
14		M12 DIN 6923	4	4

1

5 min.

Tel.: (+34) 976 457 130

The diagram for step 1 is divided into two vertical panels. The left panel shows a cartoon character in overalls reading a manual, with a clock icon indicating a 5-minute duration. The right panel shows two cartoon characters on a phone call, with a question mark above them. Below the phone call is the contact number 'Tel.: (+34) 976 457 130'. At the bottom of the panel, there are four illustrations of tools: a screwdriver, a star-shaped bit, a long-handled screwdriver, and a power drill.

2

2x

2

3

The diagram for step 2 is divided into two vertical panels. The left panel shows a close-up of a car's rear bumper with two screws being installed. A callout box labeled '1' shows two screws and a screwdriver. The right panel shows a similar view with a blue arrow labeled '2' pointing to the second screw. A callout box labeled '3' shows a screw and a star-shaped bit. To the right of the main diagram is a small illustration of a car with arrows pointing to the rear bumper area.

3

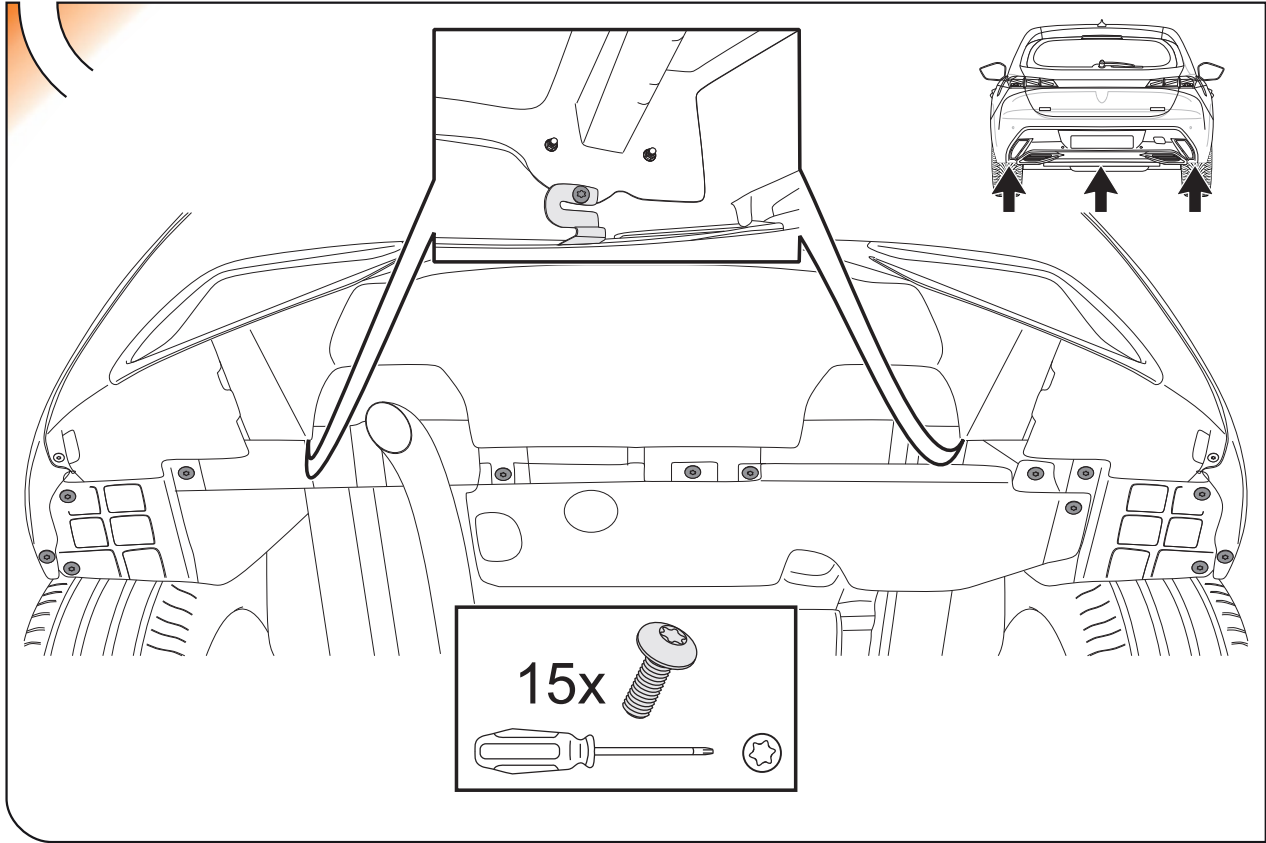

4

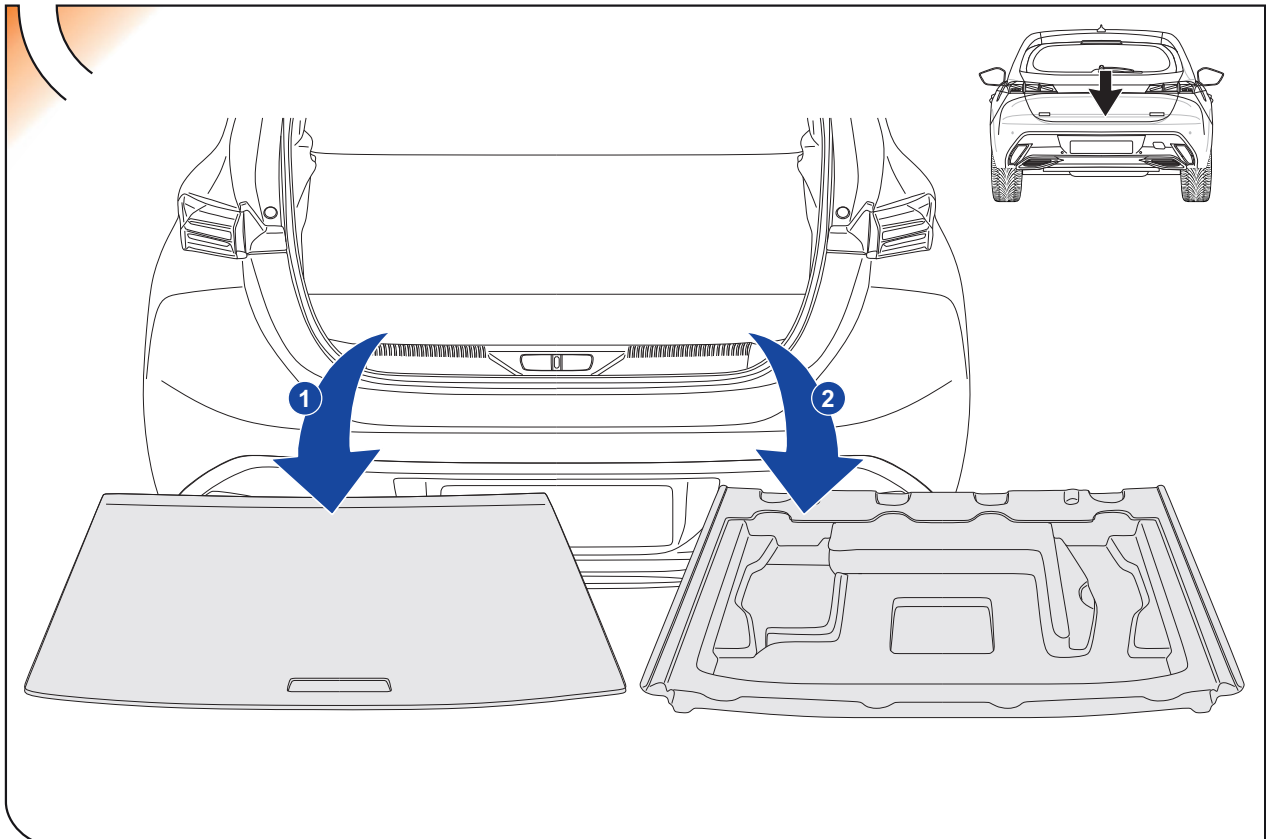

5

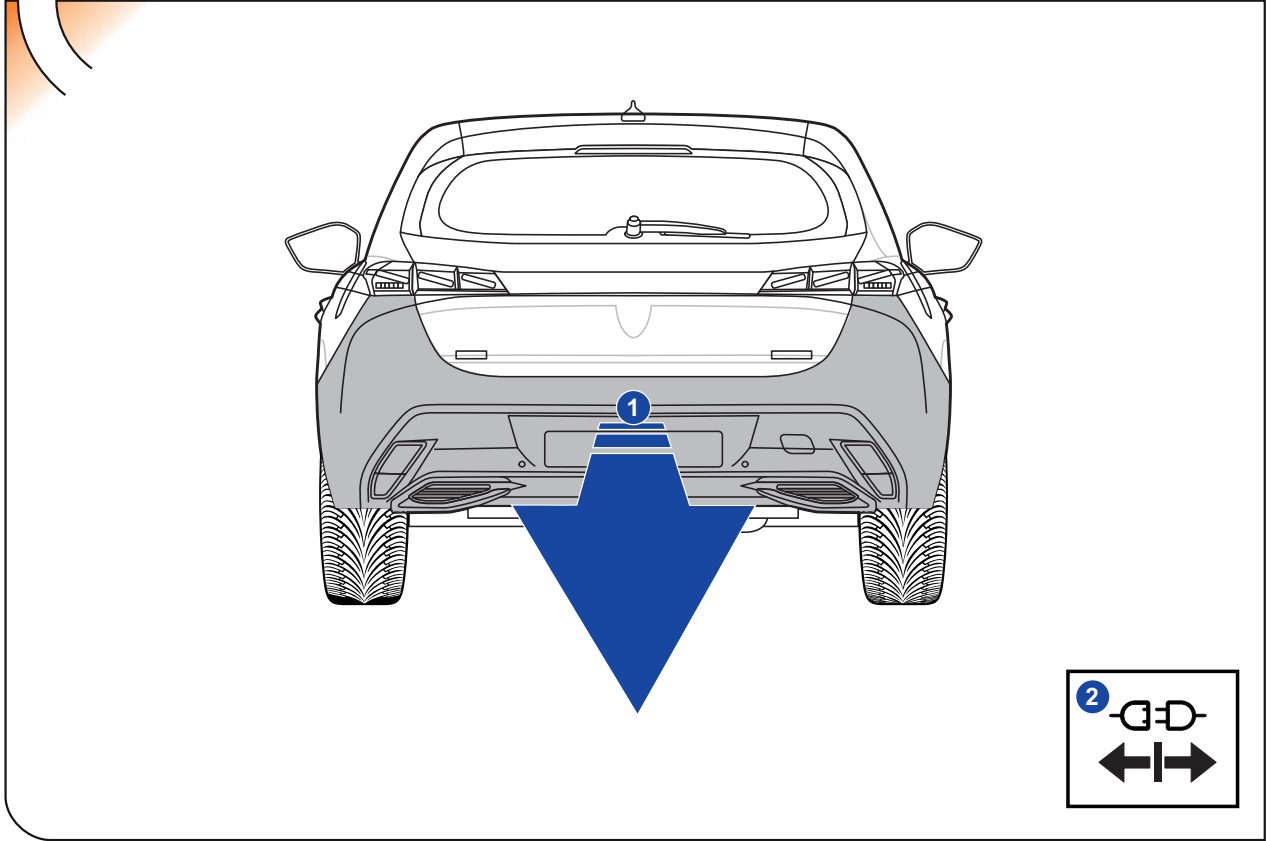

6

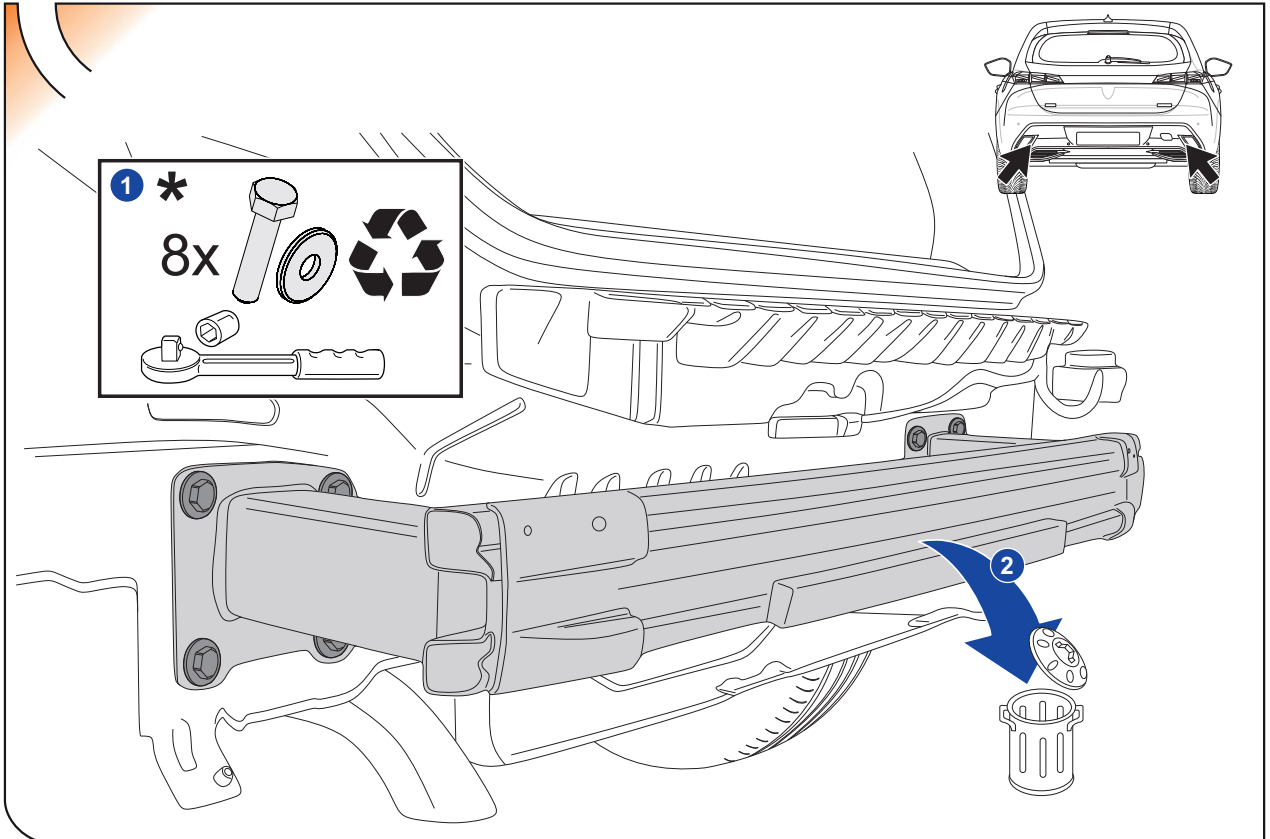

7

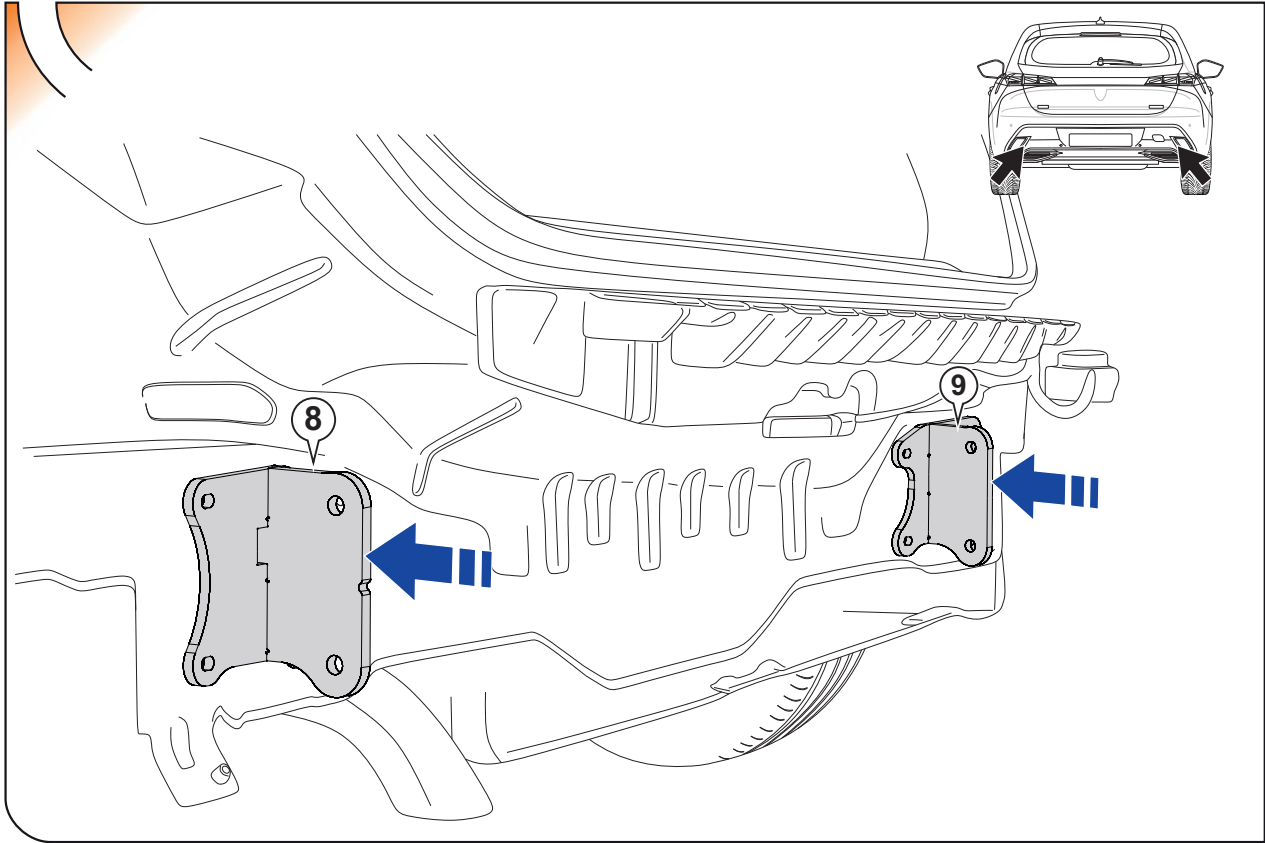

8

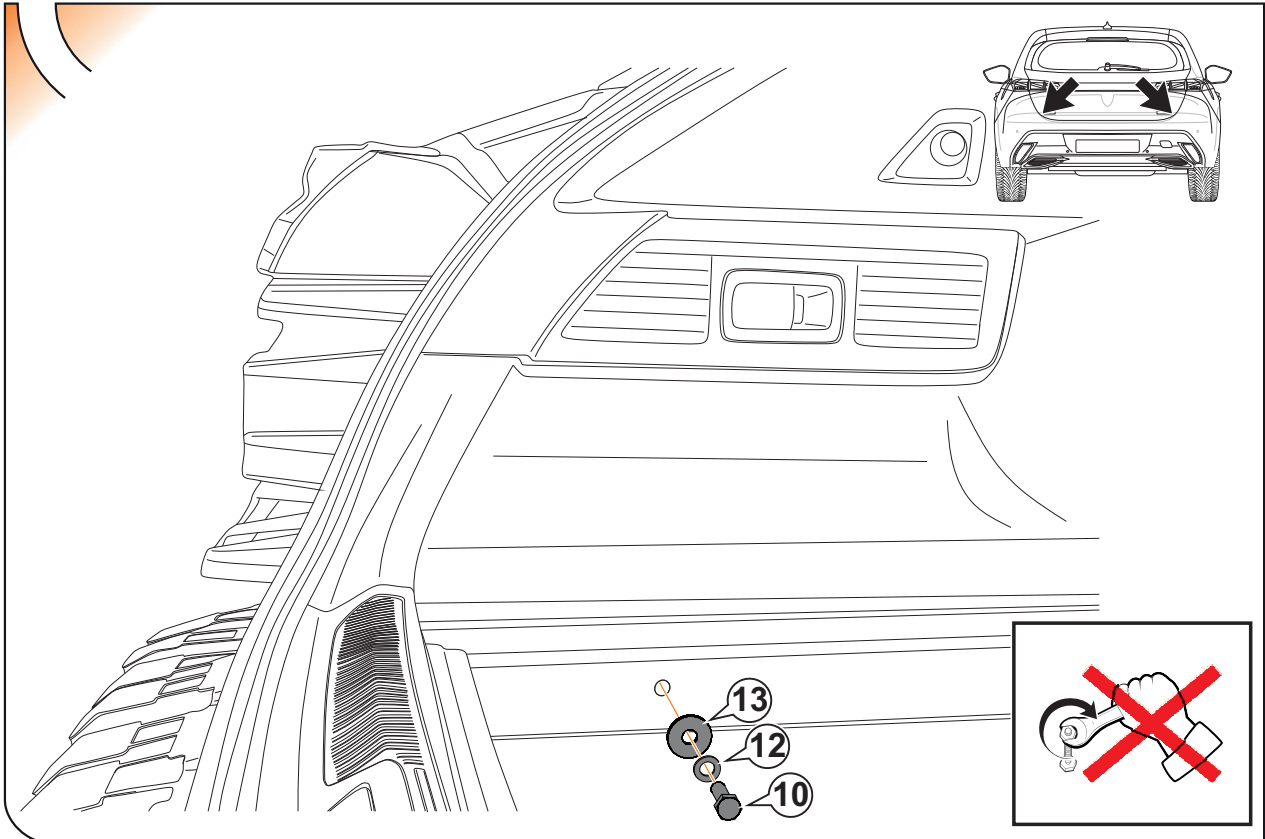

9

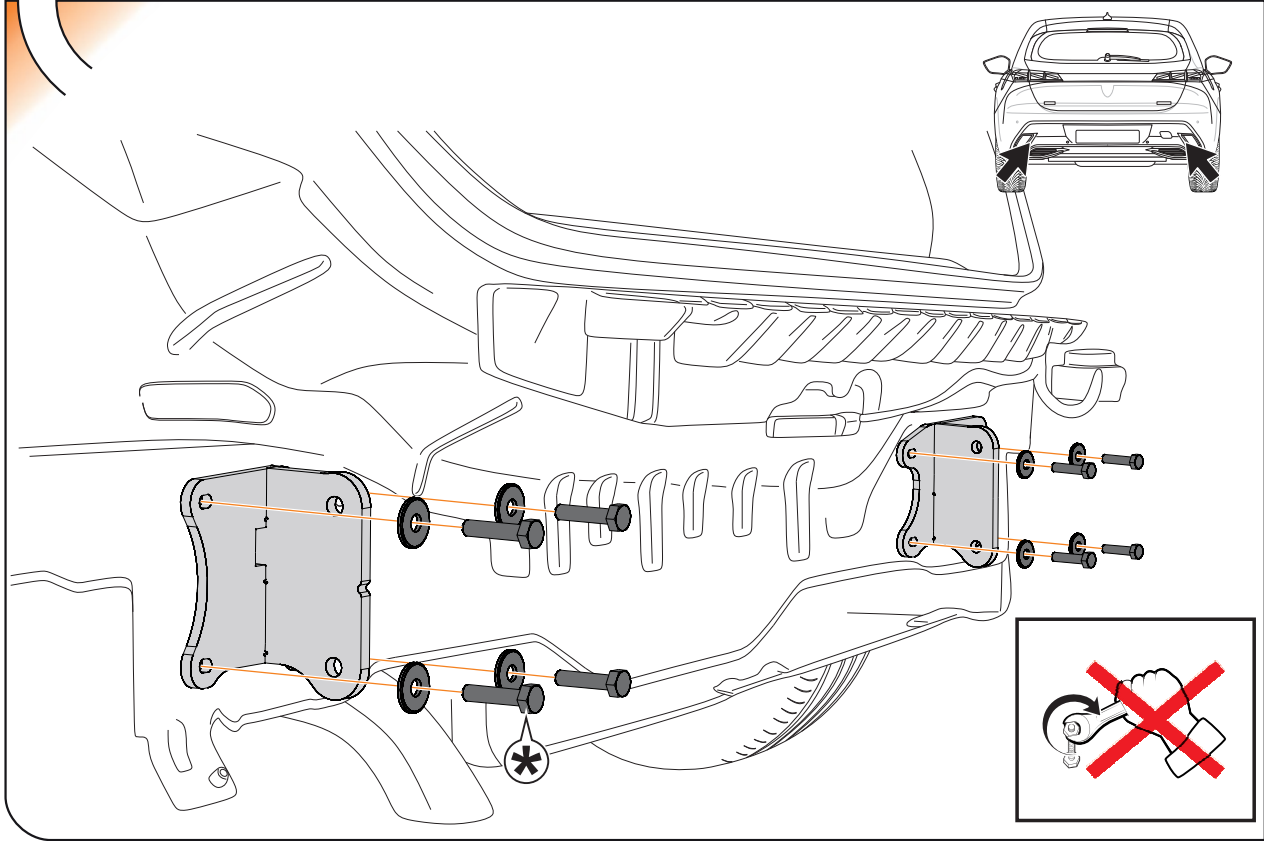

10

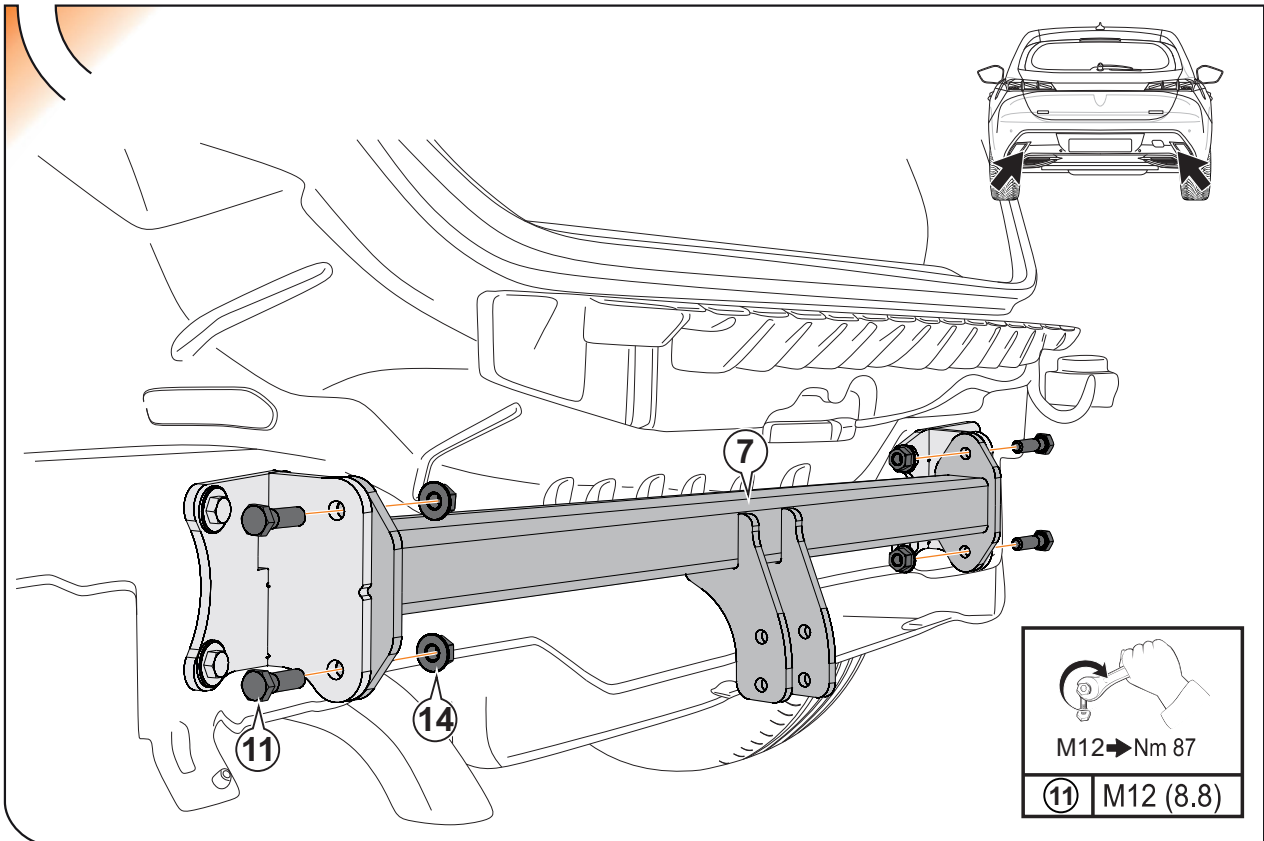

11

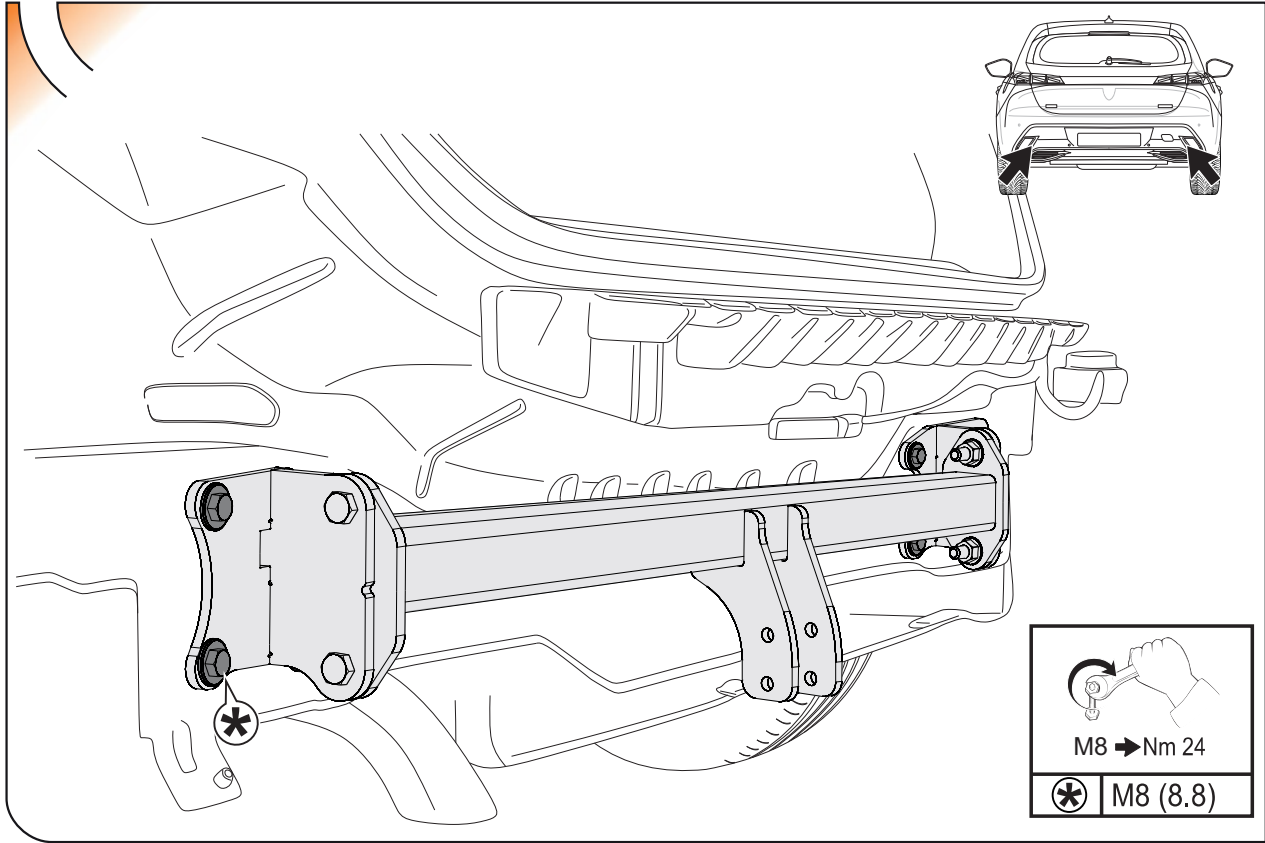

12

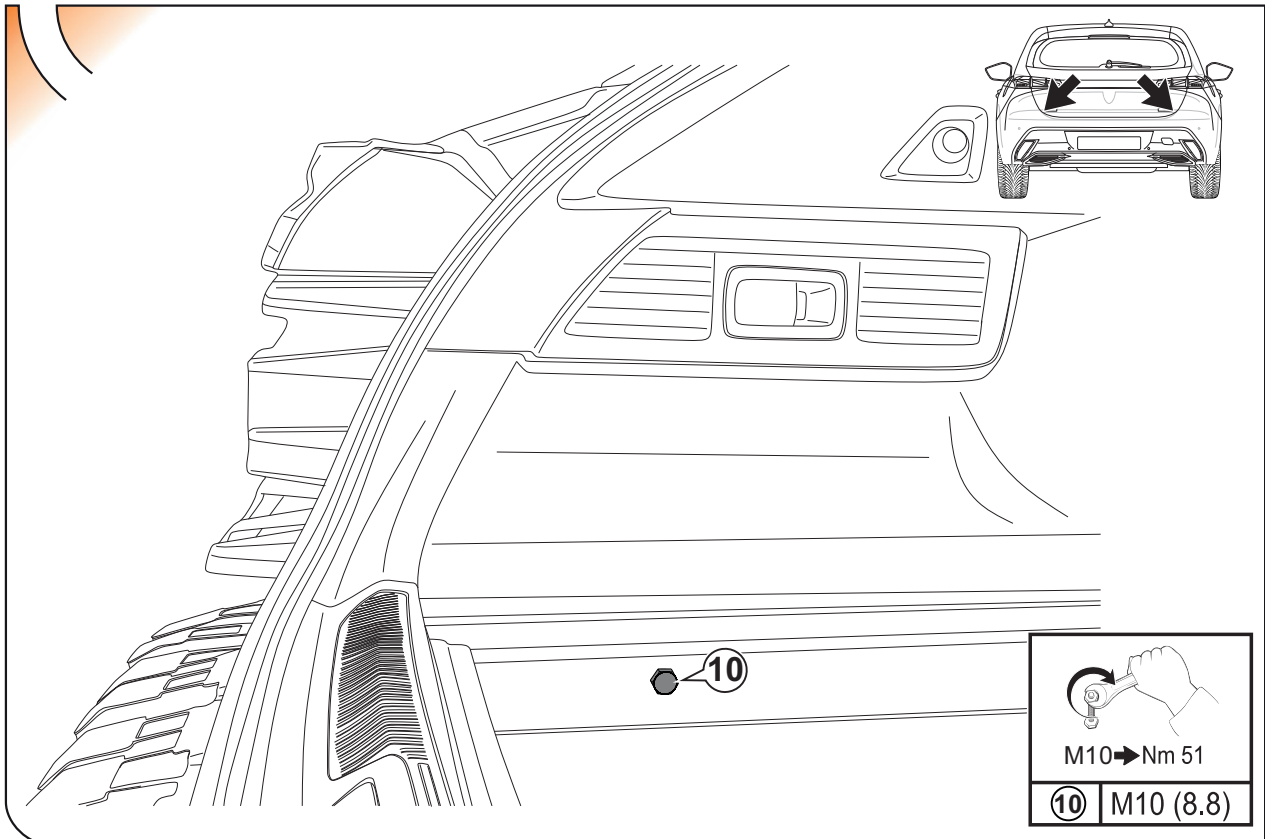

13

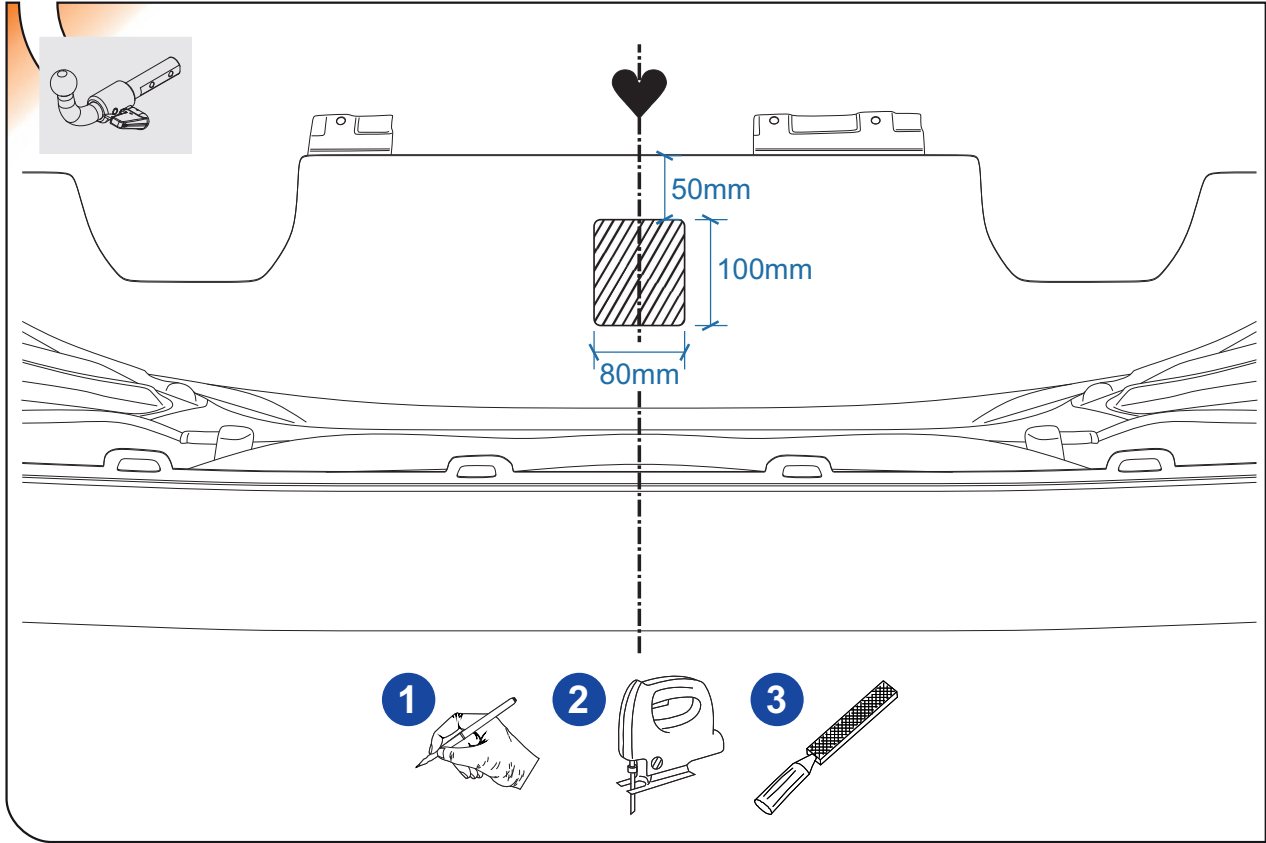

14

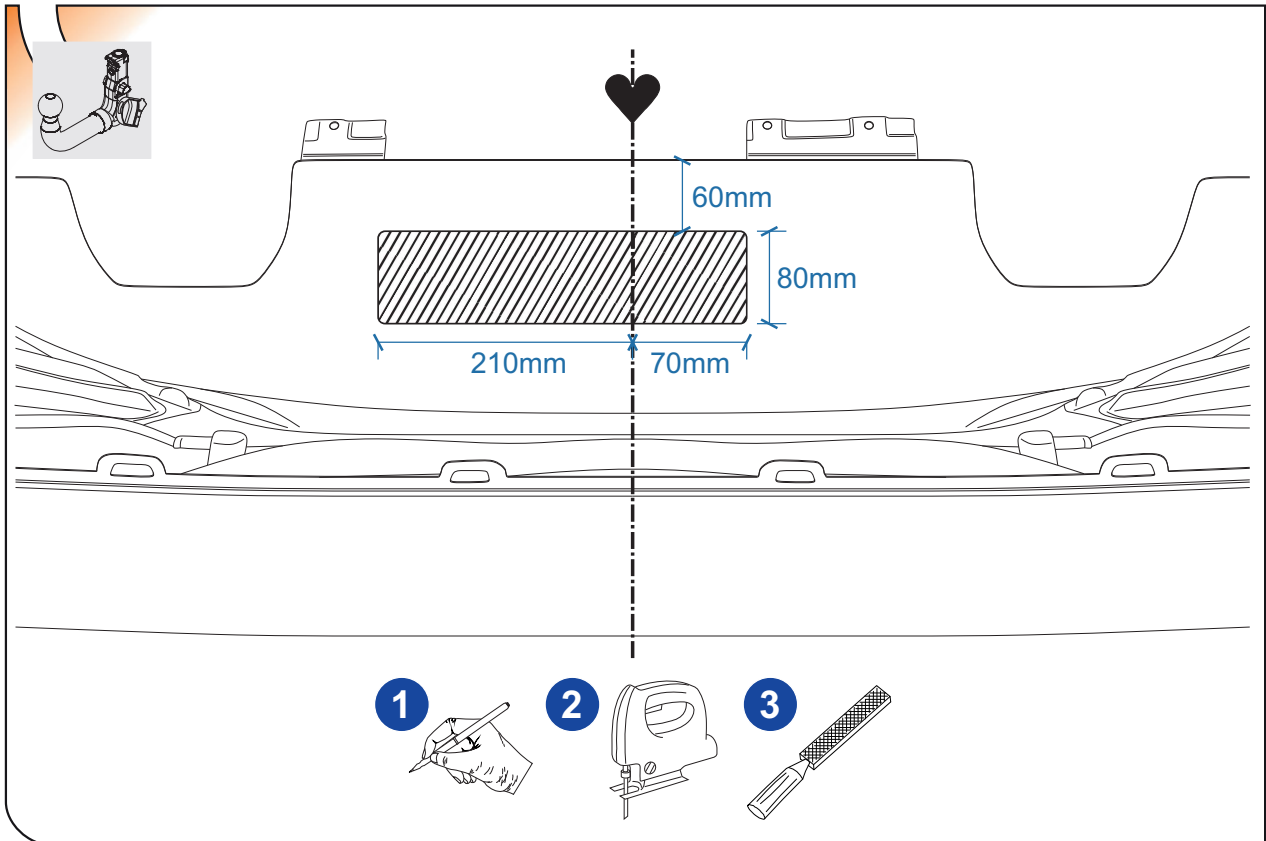

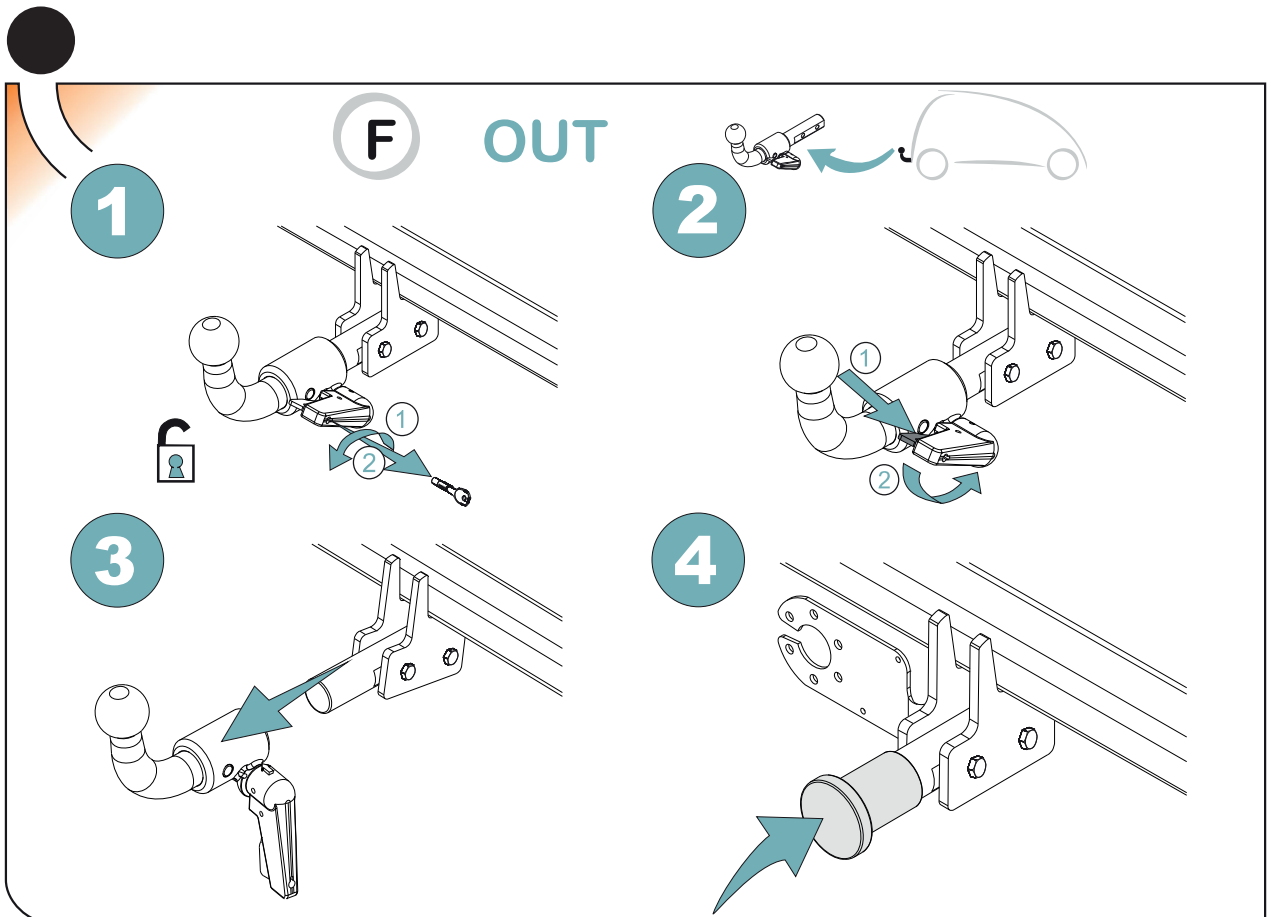
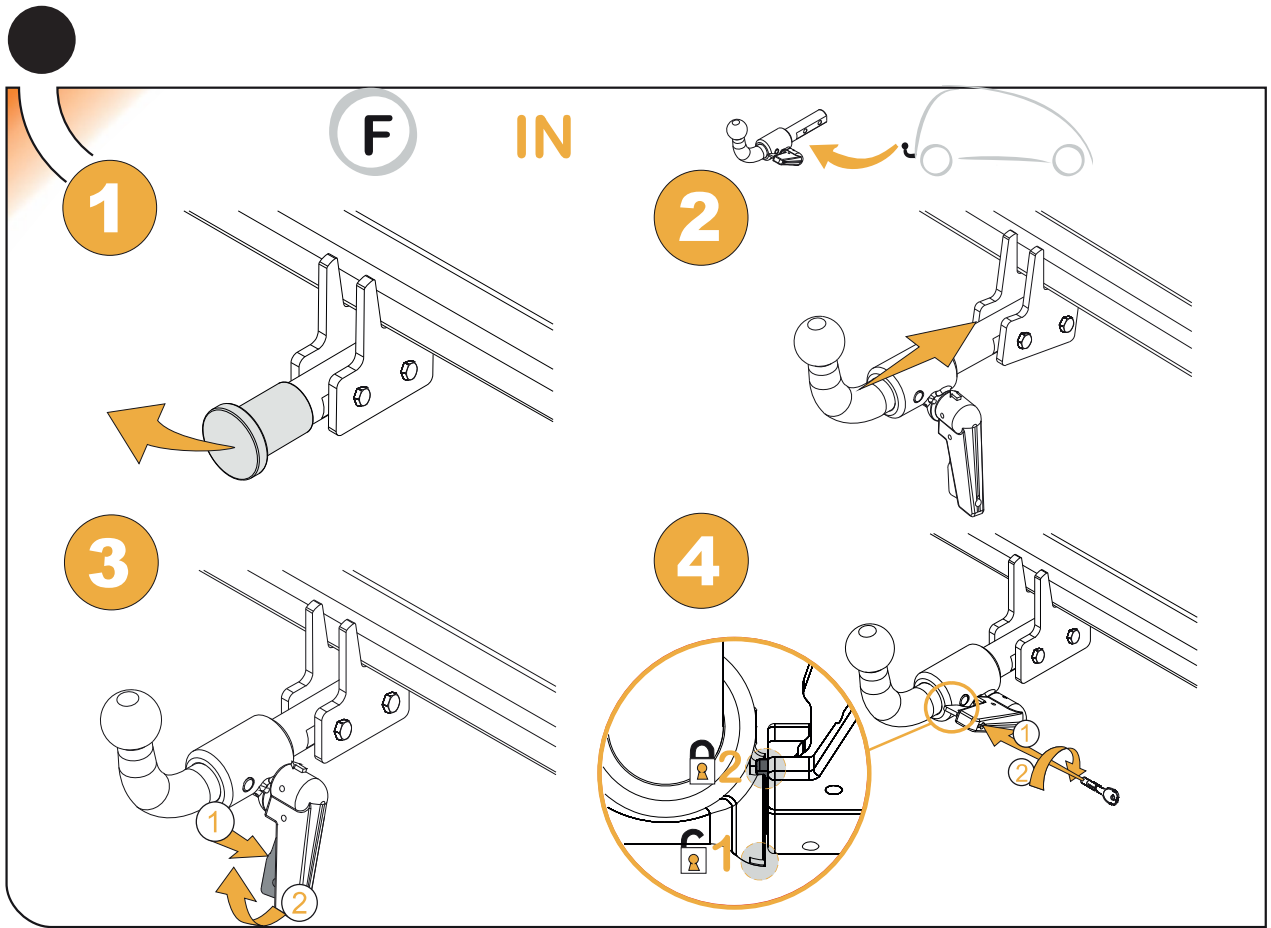

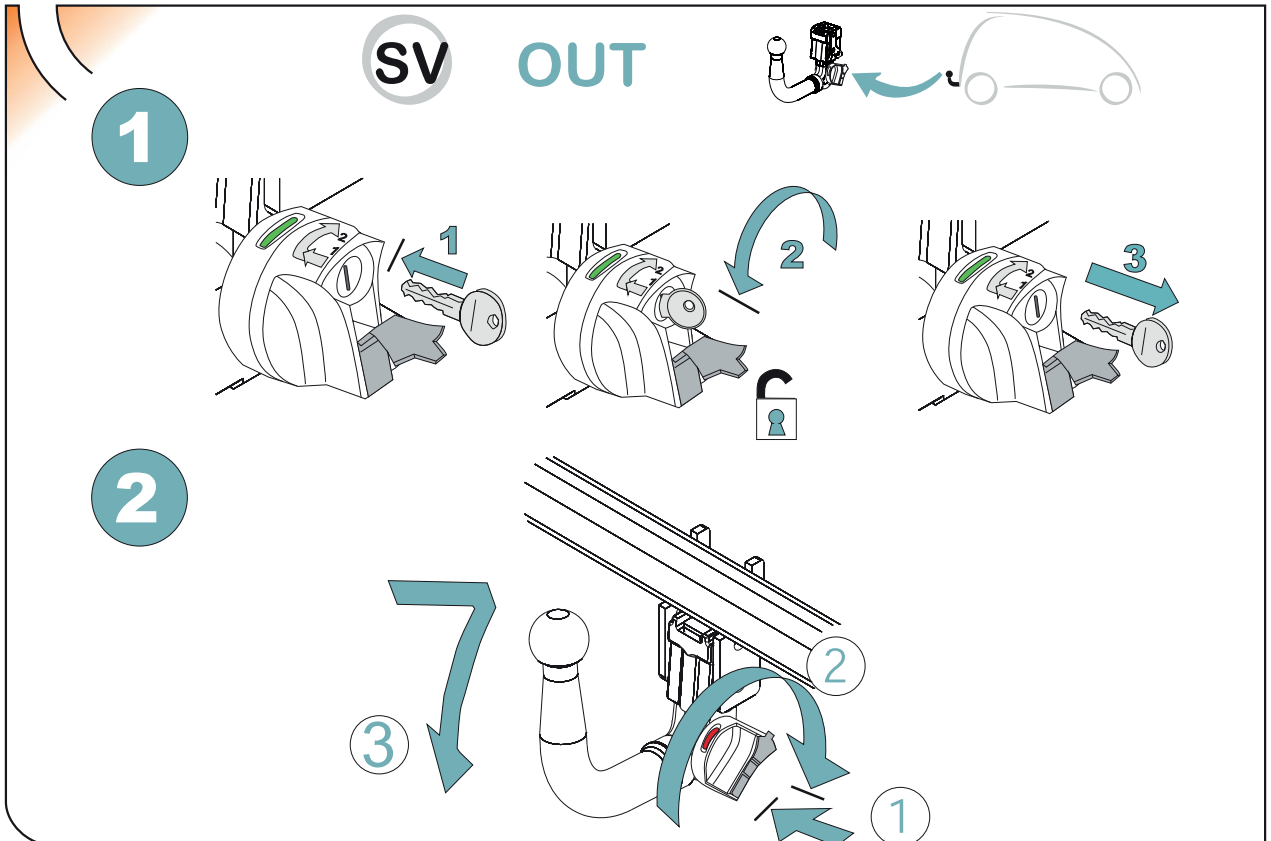
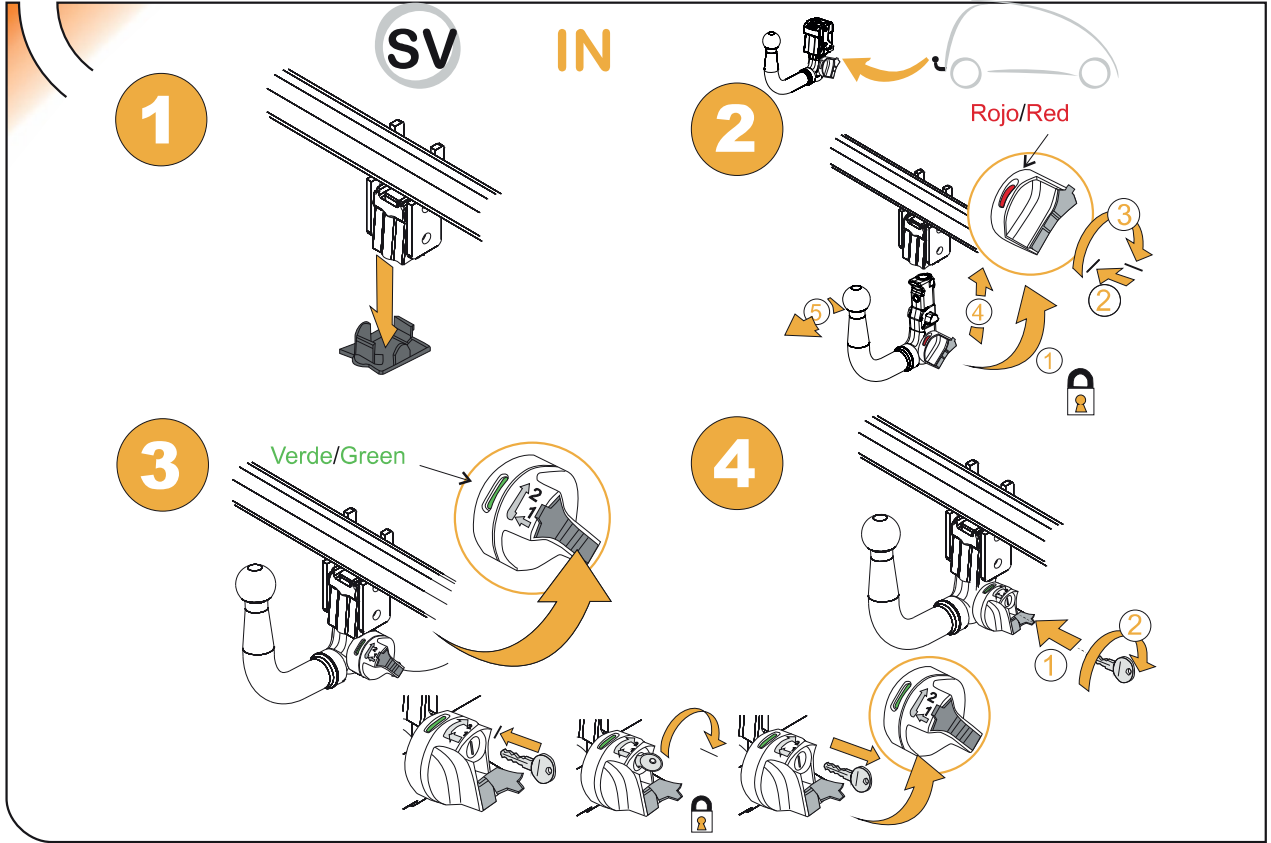

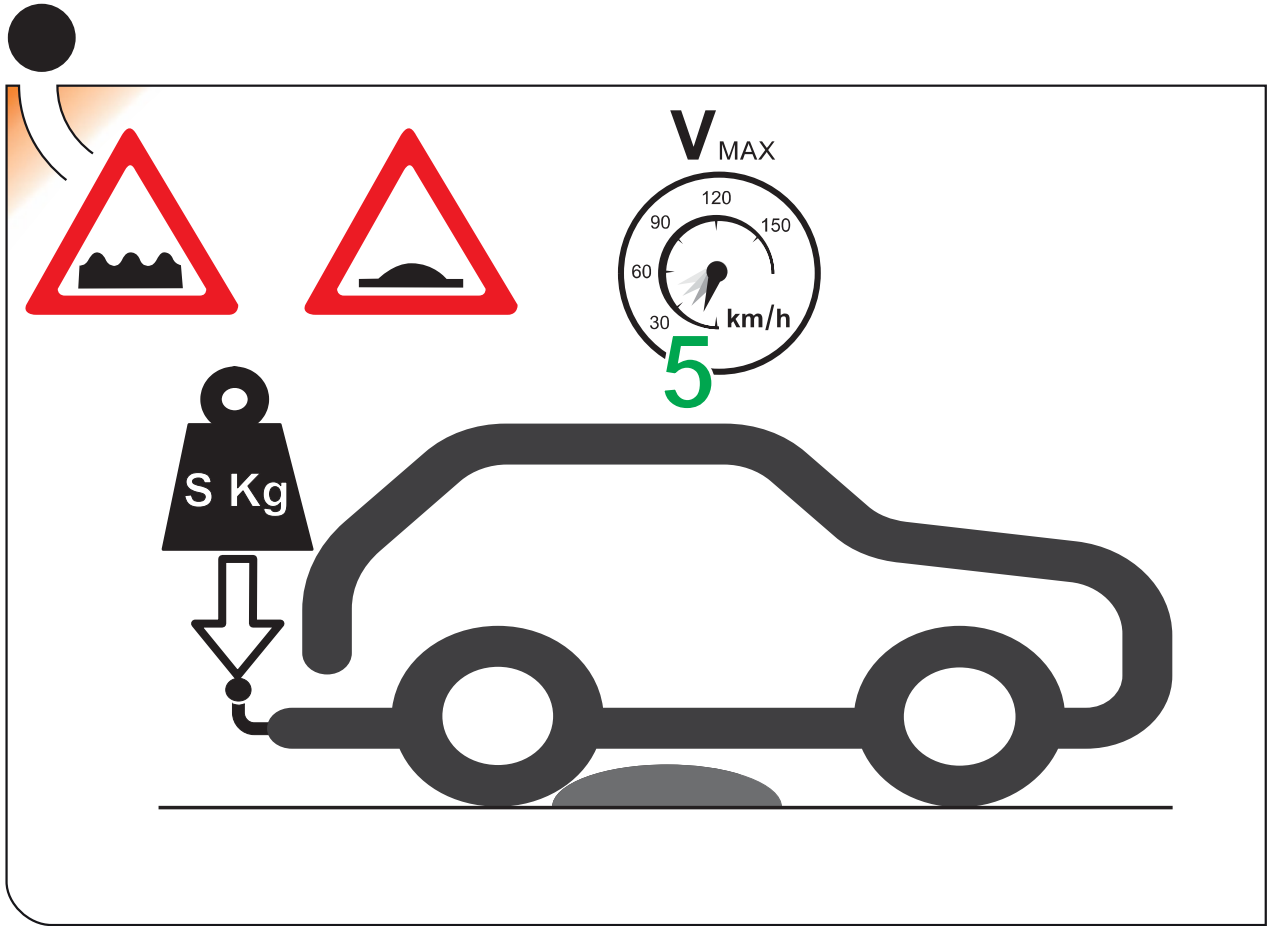

TowBox®

TowCar®

ANEXO III

CERTIFICADO DE TALLER

D. _____, expresamente autorizado por la empresa _____
domiciliada en _____, teléfono _____, dedicada
a la actividad de _____ n° de Registro Industrial _____ y n° de registro
especial (1)_____.

CERTIFICA

Que la mencionada empresa ha realizado la/s Reforma/s y asume la responsabilidad de la ejecución,
sobre el vehículo marca....., tipo.....
variante..... denominación comercial
matrícula y n° de bastidor, de acuerdo con:

- La normativa vigente en materia de reformas de vehículos.
- Las normas del fabricante del vehículo aplicables a la/s reforma/s llevadas a cabo en dicho vehículo.
- El proyecto descriptivo de la/s reforma/s, adjunto al expediente.

OBSERVACIONES: (2)

Tipificada/s con el código de reforma/s.....
Reforma consiste en:

COLOCACION DE ENGANCHE HOMOLOGADO EUROPEO MARCA:

n° de identificación / marca de homologación:

Type :

Garantizo que se cumple lo previsto en el artículo 6 del Reglamento General de vehículos y, en su caso, en el artículo 9 del R.D. 1457/1986, de 10 de enero, por el que se regula la actividad industrial en talleres de vehículos automóviles, de equipos y sus componentes, modificado por 455/2010 de 16 de abril.

....., a.....de.....de

Firma y sello:

(1) En el caso de que la reforma sea efectuada por el fabricante se indicará N/A.

(2) Se debe especificar en este apartado OBSERVACIONES, la identificación de los equipos o sistemas modificados.

ES

1



2



3



IT

1

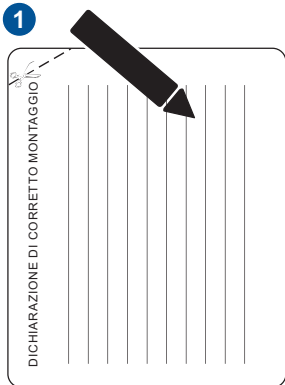

2

