

**Volkswagen ID.3 (2020- )  
Cupra Born (2021- )**

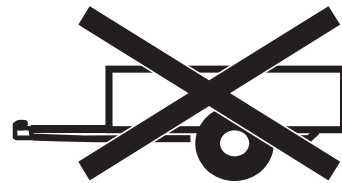

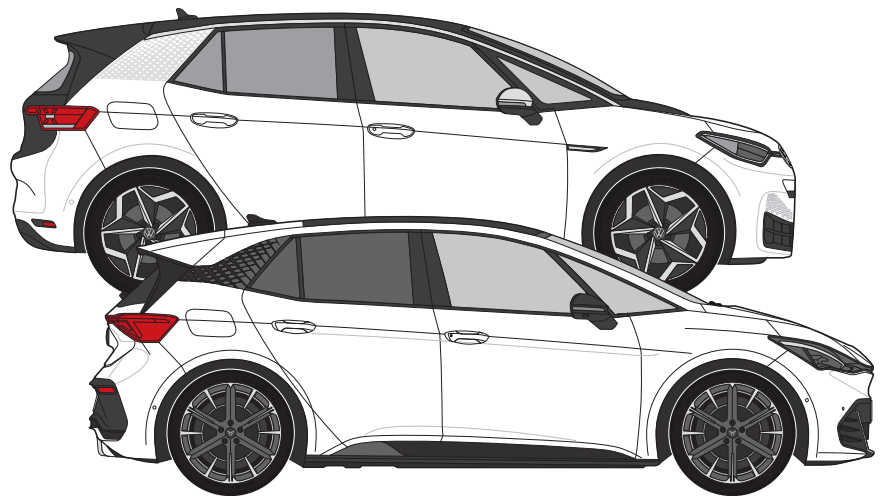



Volkswagen ID.3 (2020-)

Cupra Born (2021-)

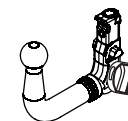

- ES** Este dispositivo ha sido diseñado y testado para soportar solamente cargas puntuales. Su uso solo es válido para transportar portabicicletas, portaequipajes o dispositivos suspendidos sobre la bola. En ningún caso y bajo ninguna circunstancia está permitido este dispositivo para remolcar. Enganches y Remolques Aragón, S.L. no se hará responsable de cualquier daño o reclamación derivada de un mal uso.
- GB** This device has been designed and tested for supporting exclusively occasional loads . Its use is suitable only for carrying bike carriers, luggage carriers or other devices fitted to the towball. It's not allowed to use this device for towing anything in any case. Enganches y Remolques Aragón, S.L. declines any responsibility or claim in case that it was not properly used.
- FR** Cet appareil a été conçu et testé pour supporter uniquement des charges ponctuelles. Son utilisation n'est valable que pour le transport de porte-vélos, porte-bagages ou autres dispositifs suspendus sur la rotule. En aucun cas et en aucune circonstance cet appareil n'est autorisé à remorquer. Enganches y Remolques Aragón, S.L. ne sera en aucun cas responsable de tout dommage ou réclamation découlant d'une mauvaise utilisation.
- IT** Questo dispositivo è stato progettato e testato per supportare esclusivamente cariche puntuali. Il suo utilizzo è valido solo per il trasporto di portabiciclette, portabagagli o dispositivi sospesi sulla sfera del gancio di traino. In nessun caso e in nessuna circostanza questo dispositivo può trainare. Enganches y Remolques Aragón, S.L. non sarà ritenuto responsabile per eventuali danni o reclami derivati da un uso improprio.
- DE** Dieses Gerät wurde entwickelt und getestet, um punktlích Lasten zu tragen. Die Verwendung gilt nur für den Transport von Fahrradträgern, Gepäckträger oder an der Kugel befestigten Geräten. In keinem Fall und unter keinen Umständen darf dieses Gerät ziehen. Enganches y Remolques Aragón, S.L. haftet nicht für Schäden oder Ansprüche, die durch Missbrauch entstehen.
- NL** Dit onderdeel is ontworpen en getest om uitsluitend een punctueel last te dragen. Het kan alleen gebruikt worden dragen van fietsendragers, bagagedragers of andere producten die op de trekhaak worden gemonteerd. Het is niet toegestaan om met dit product iets te trekken. Enganches y Remolques Aragón, S.L. weigert elke aansprakelijkheid of claim in het geval het product niet op de juiste wijze in gebruikt.
- TR** Bu ürün sadece ara sira yükleri taşımak için tasarlanmış ve denenmiştir. Kullanımı sadece bisiklet taşıyıcıları, bagaj taşıyıcıları, ya da çeki demirine uyumlu diğer donanımlar içindir. Bu ürünün başka hiçbir şey çekmek için kullanılmasına izin verilmemelidir. Enganches y Remolques Aragón, S.L., bu ürünün uygun olmayan şekillerde kullanılmasından doğacak hiçbir iddia ve zarar talebinden sorumlu değildir.
- GR** Αυτός ο μηχανισμός σχεδιάστηκε και ελέγχθηκε ειδικά για περιστασιακά φορτία.Χρησιμοποιείται μόνο για μεταφορά βάσεων ποδηλάτων ,μπαγκαζιερών και άλλων συσκευών οι οποίες εφαρμόζονται σε κοτσαδόρους.Δεν επιτρέπεται η χρήση αυτών των συσκευών για έλξη ή ρυμούλκηση σε καμία περίπτωση .Η εταιρεία ENGANCHES y REMOLQUES ARAGON S.L αποποιείται κάθε ευθύνη σε περίπτωση μη σωστής
- PT** Este dispositivo foi desenhado e testado para suportar somente cargas pontuais. Apenas serve para transportar bicicletas, porta bagagens ou dispositivos suspensos sobre a bola. Em caso algum e sob nenhum circunstância está autorizado para rebocar. Enganches y Remolques Aragón, S.L. não se responsabilizará de qualquer dano ou reclamação motivada por um mal uso.
- RU** Данное устройство разработано и протестировано только для случайных нагрузок. Его использование возможно только для велосипедных креплений, креплений для груза или других креплений такого рода, устанавливаемых на шар ТСУ. Использование данного устройства для буксировки какого-либо прицепа не допустимо. Компания Enganches y Remolques Aragón, S.L. снимает с себя любую ответственность при некорректном использовании данного устройства.
- PL** To urządzenie zostało zaprojektowane i przetestowane wyłącznie do przewożenia obciążeń sporadycznych, takich jak bagażniki rowerowe, kufry lub inne urządzenia dopasowane do przewożenia na haku. Niedopuszczalnym jest używanie tego urządzenia do holowania czegokolwiek. Enganches y Remolques Aragón, S.L. odrzuca wszelkie roszczenia oraz nie ponosi żadnej odpowiedzialności w przypadku nieprawidłowego
- CZ** Toto zařízení bylo navrženo a testováno výhradně pro podporu příležitostných nákladů. Jeho použití je vhodné pouze pro převoz nosičů kol, nosičů zavazadel a dalších zařízení upevněných na kulový čep. V žádném případě není povoleno jeho použití za účelem tažení (např. přívěsu). Enganches y Remolques Aragón, S.L. se zřiká jakékoli odpovědnosti nebo nároků v případě, bude-li zařízení nevhodně použito.

N/m	M6	M8	M10	M12	M14	M16
8,8	10	24	51	87	138	200
10,9	15	36	75	130	198	289
12,9	18	42	87	147	231	341

0 km      1000 km

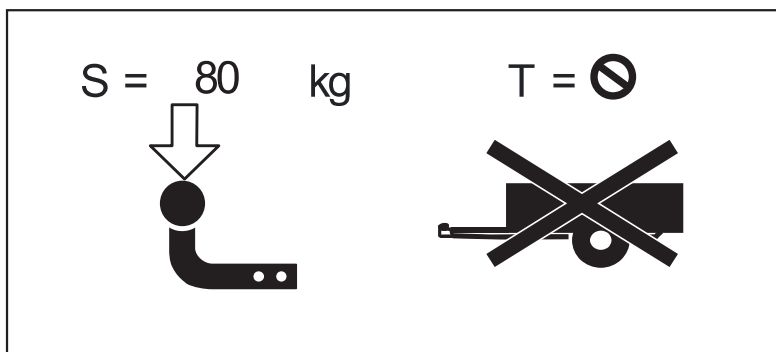

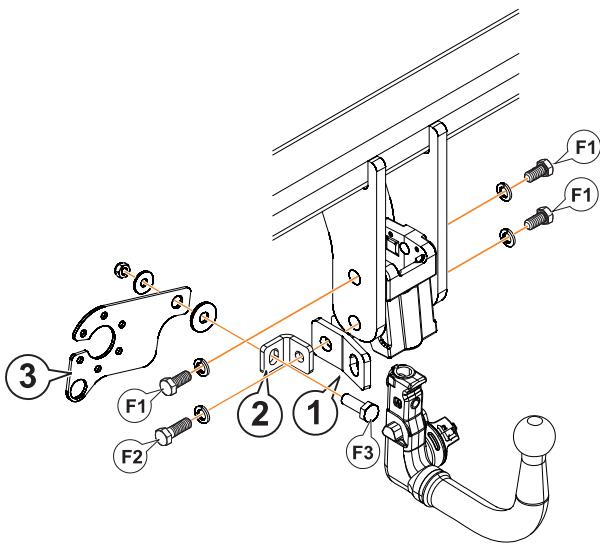
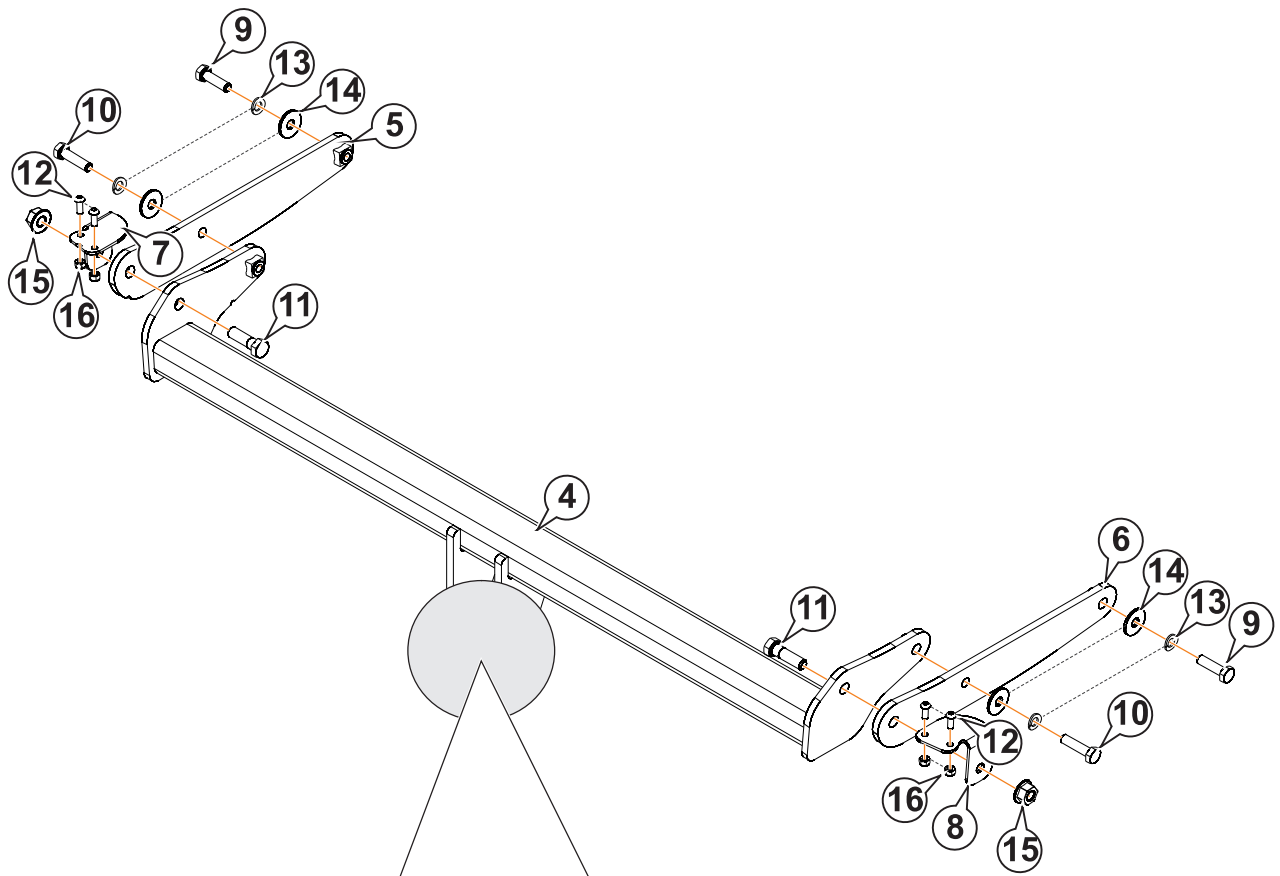

		#
<b>F1</b>	M12 x 25 DIN 933	3
	Ø12 Grower DIN 128	3
	M12 x 35 DIN 933	1
<b>F2</b>	Ø12 Grower DIN 128	1
	M10 x 30 DIN 933	1
	Ø10 Poliuretano / Nylon	1
	Ø10 DIN 9021	1
<b>F3</b>	M10 DIN 980	1

M12 → Nm 87  
M10 → Nm 51

<b>F1</b>	M12 (8.8)
<b>F2</b>	M12 (8.8)
<b>F3</b>	M10 (8.8)

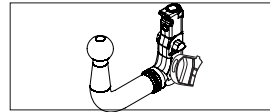

1		AEV0006	1	
2		AEV0008	1	
3		AEV0009	1	
4		C6721AV60	1	
5		C6721AV22	1	
6		C6721AV21	1	
7		C6721AV26	1	
8		C6721AV25	1	
9		M10x35 DIN 933 (8.8)	2	
10		M10x45 DIN 933 (8.8)	2	
11		M12x40 DIN 933 (8.8)	2	
12		M6x16 DIN 7380 (8.8)	4	
13		Ø10 DIN 128A	4	
14		Ø10 DIN 9021	4	
15		M12 DIN 6923	2	
16		M6 DIN 980	4	



1



5 min.

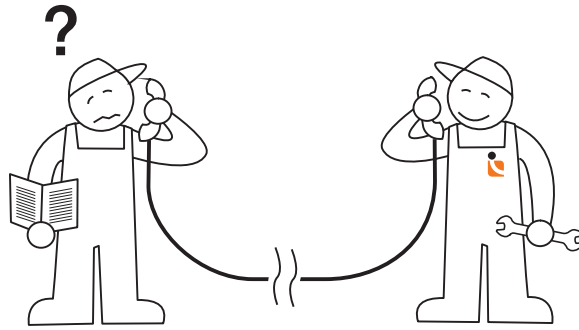

Tel.: (+34) 976 457 130

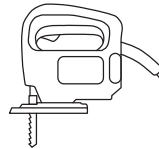
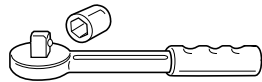
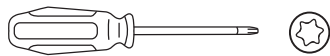

2

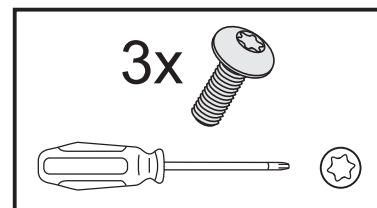
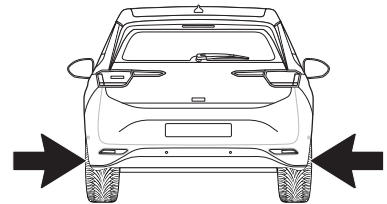
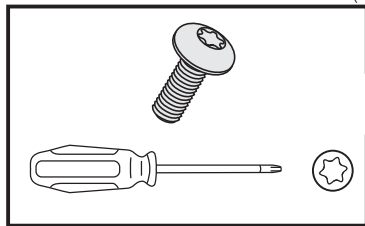



**3**

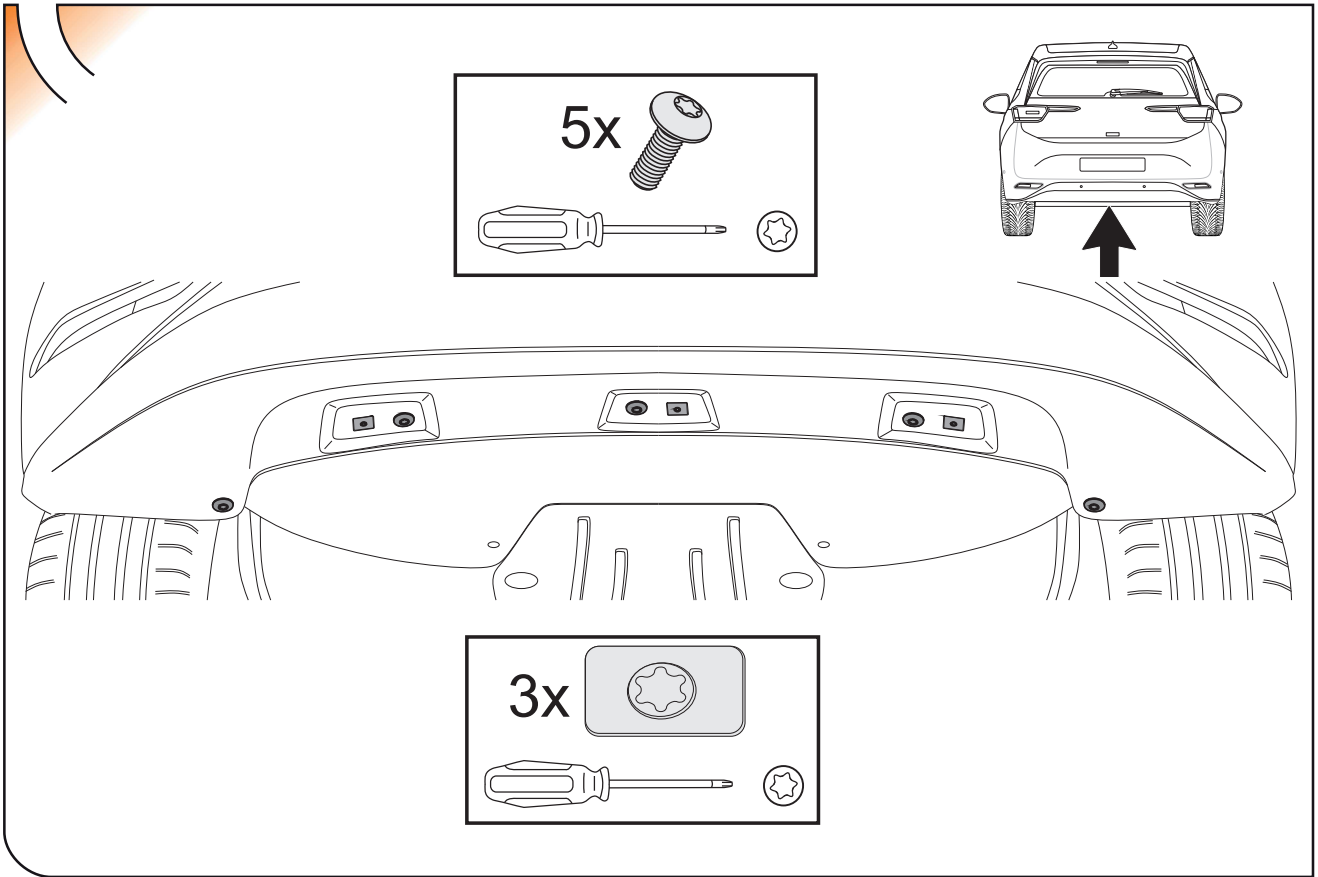

**4**

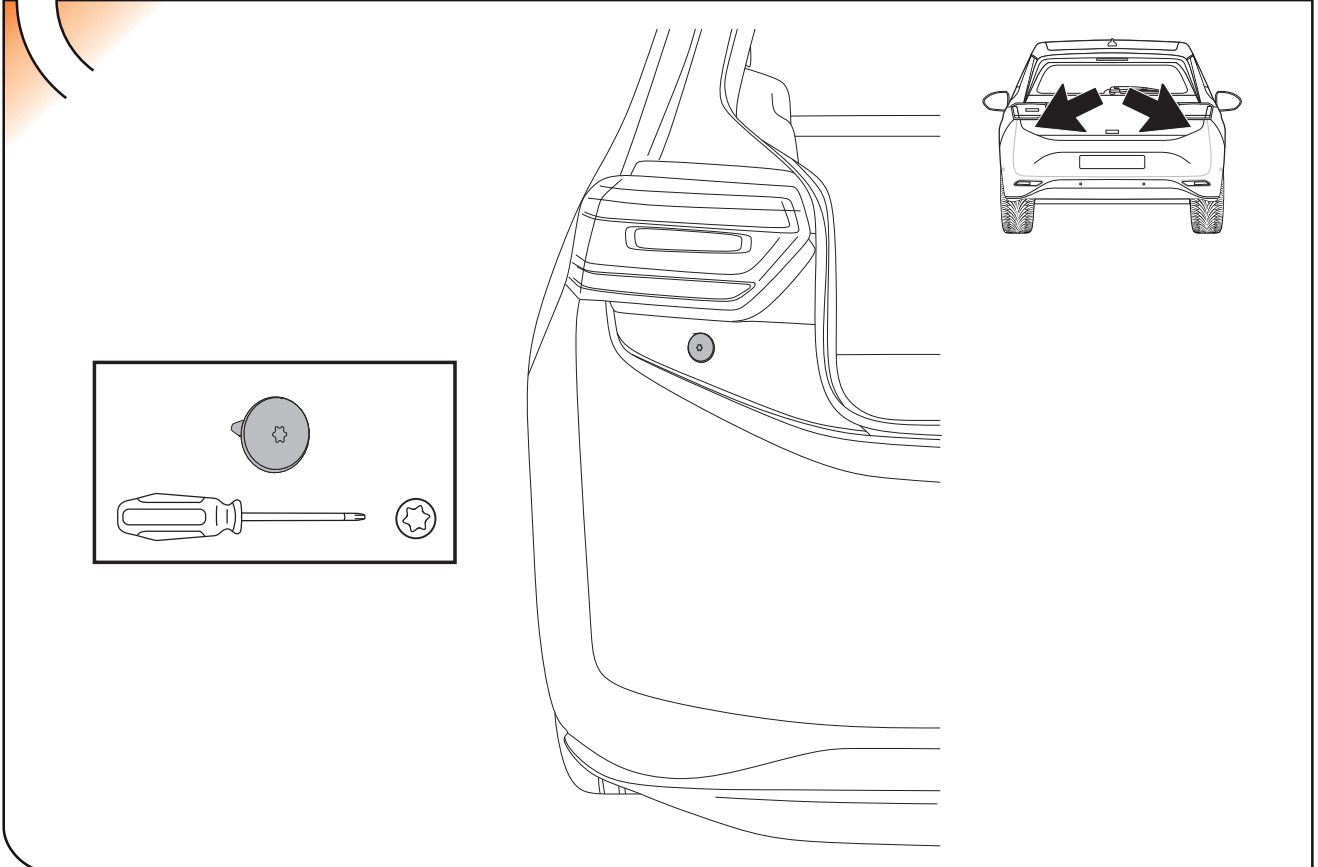



5

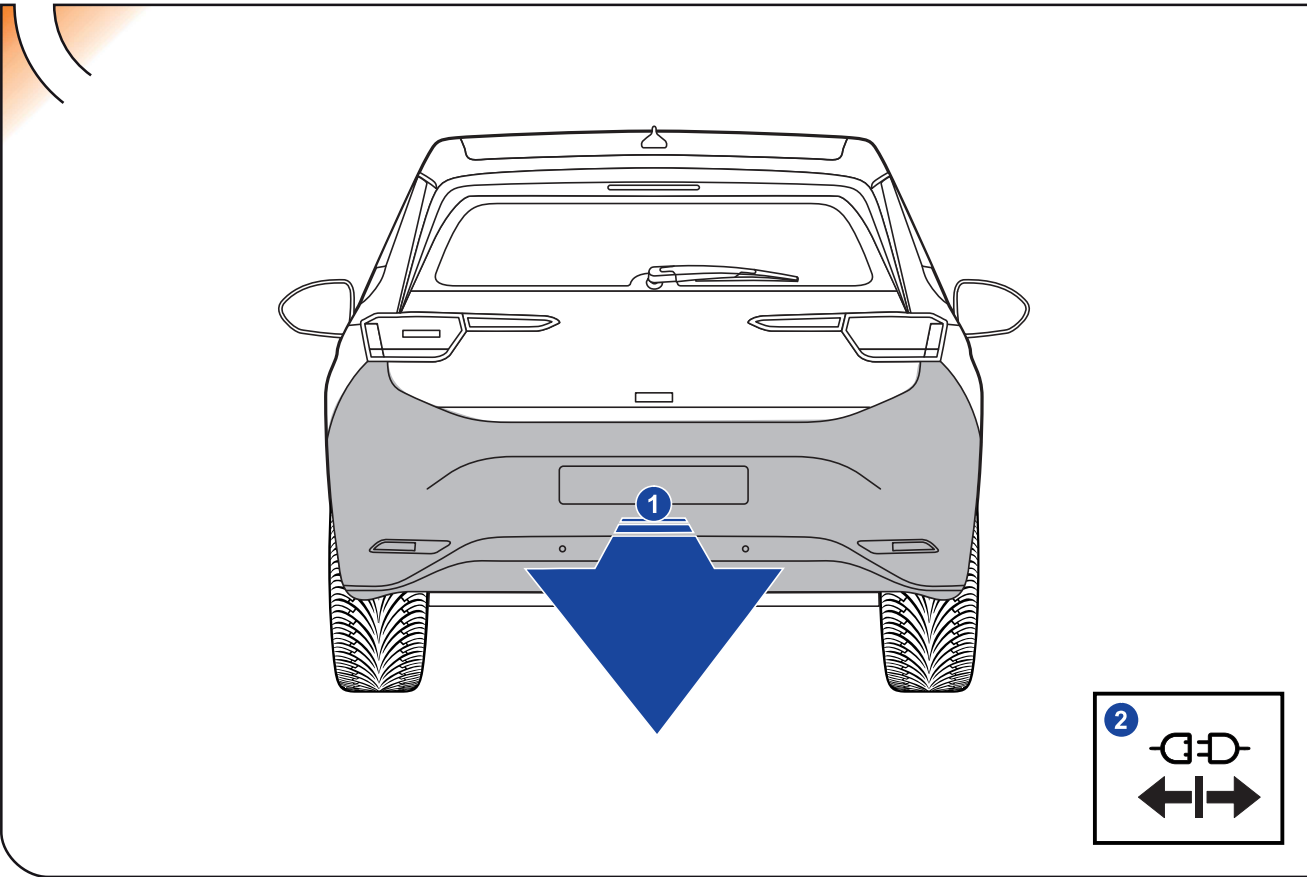

6

OPTIONAL

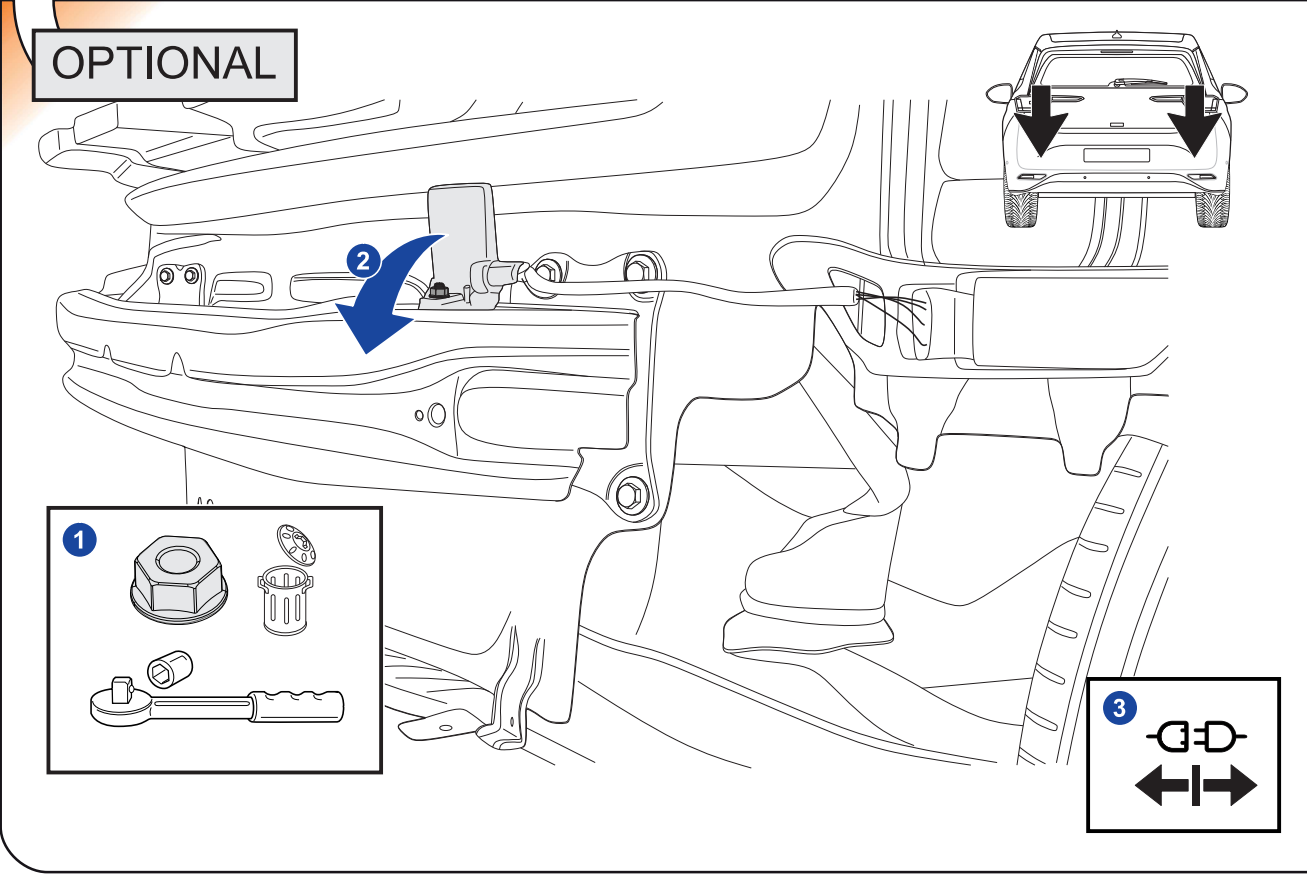





7

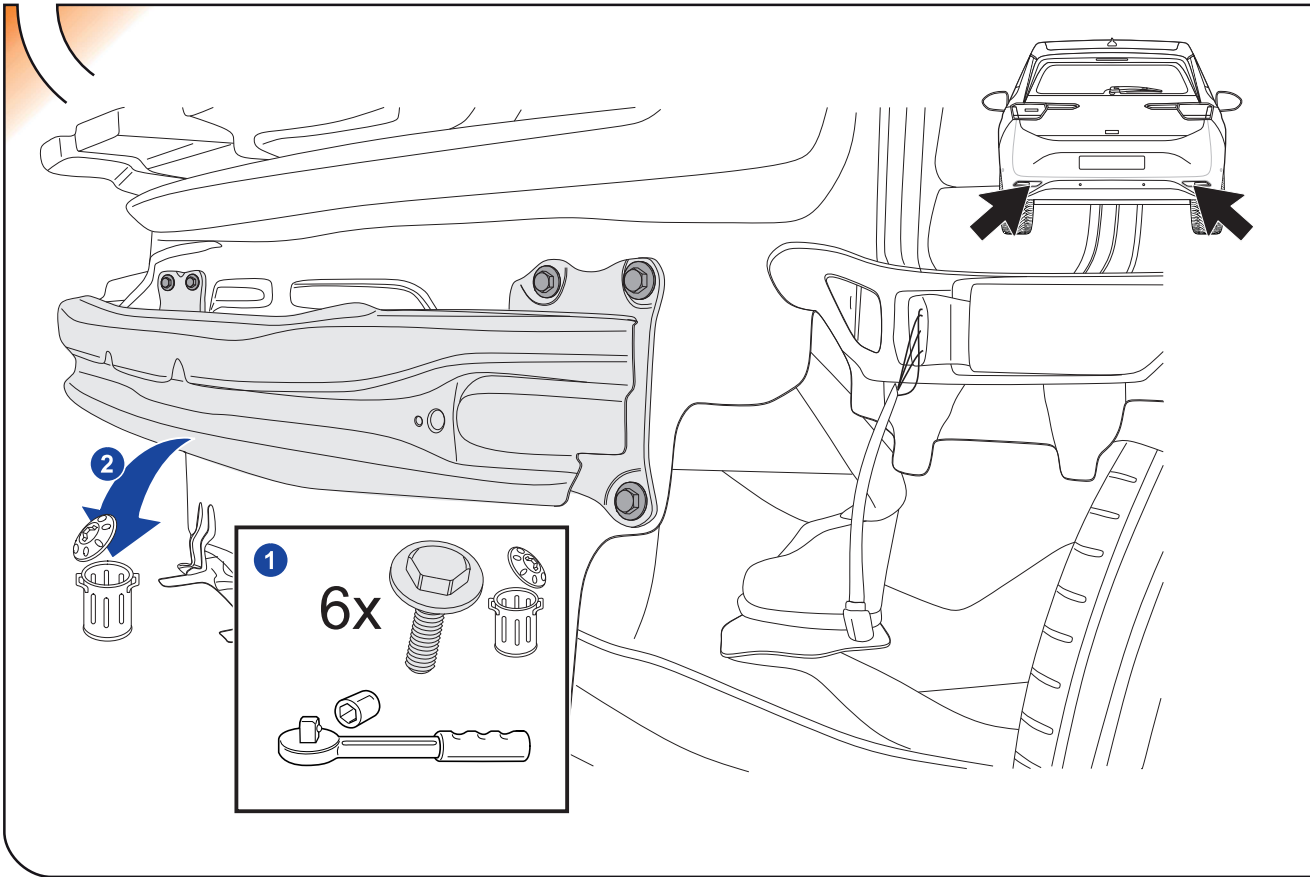

8

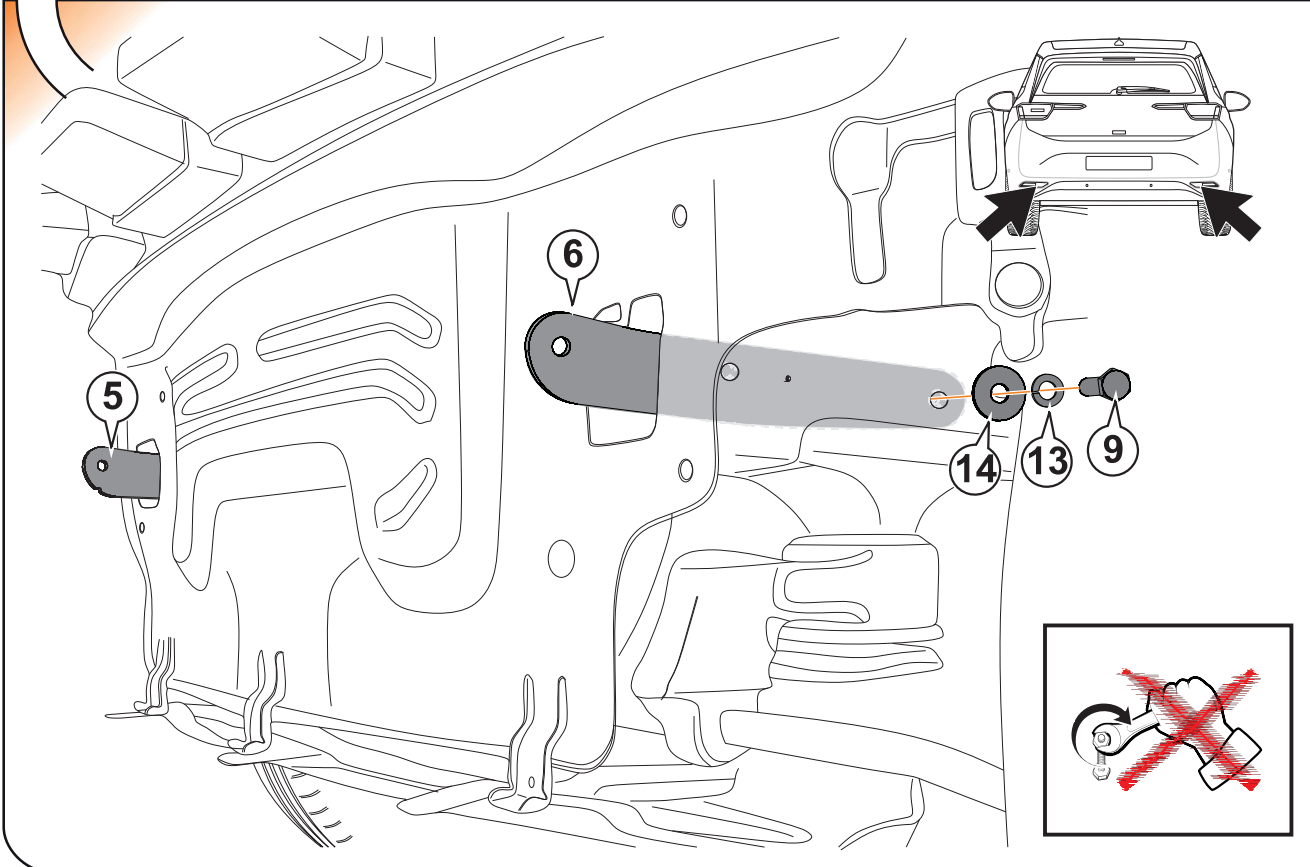



9

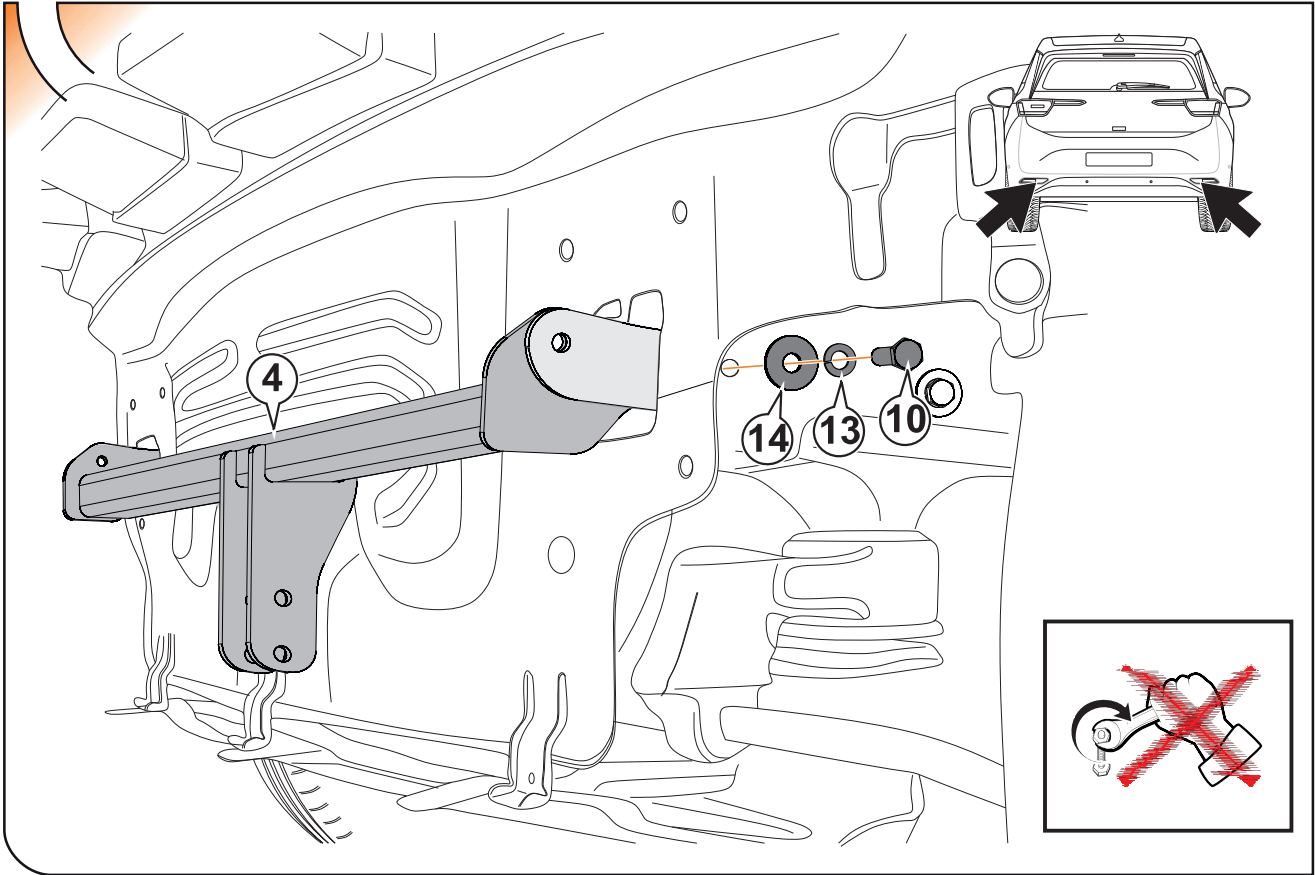

10

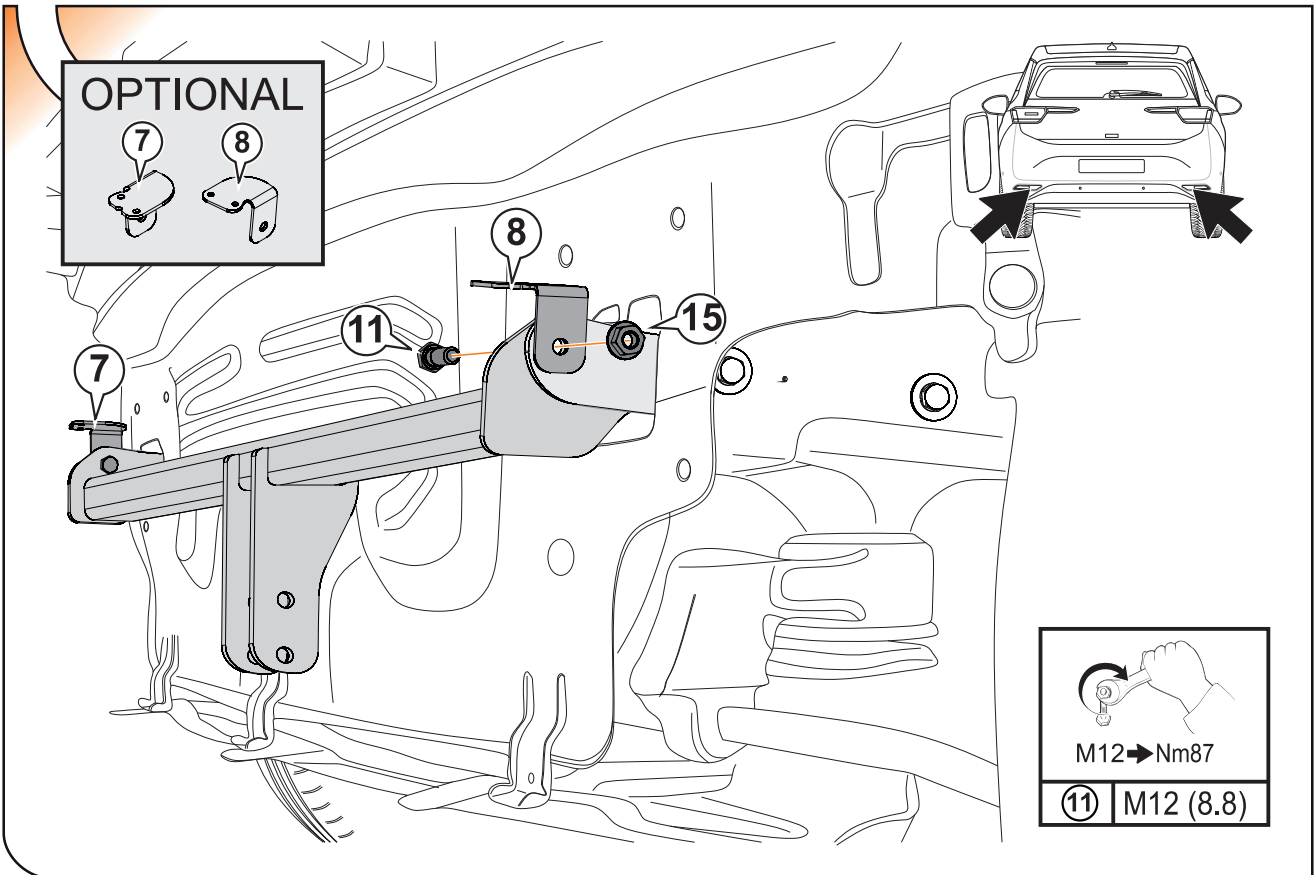



11

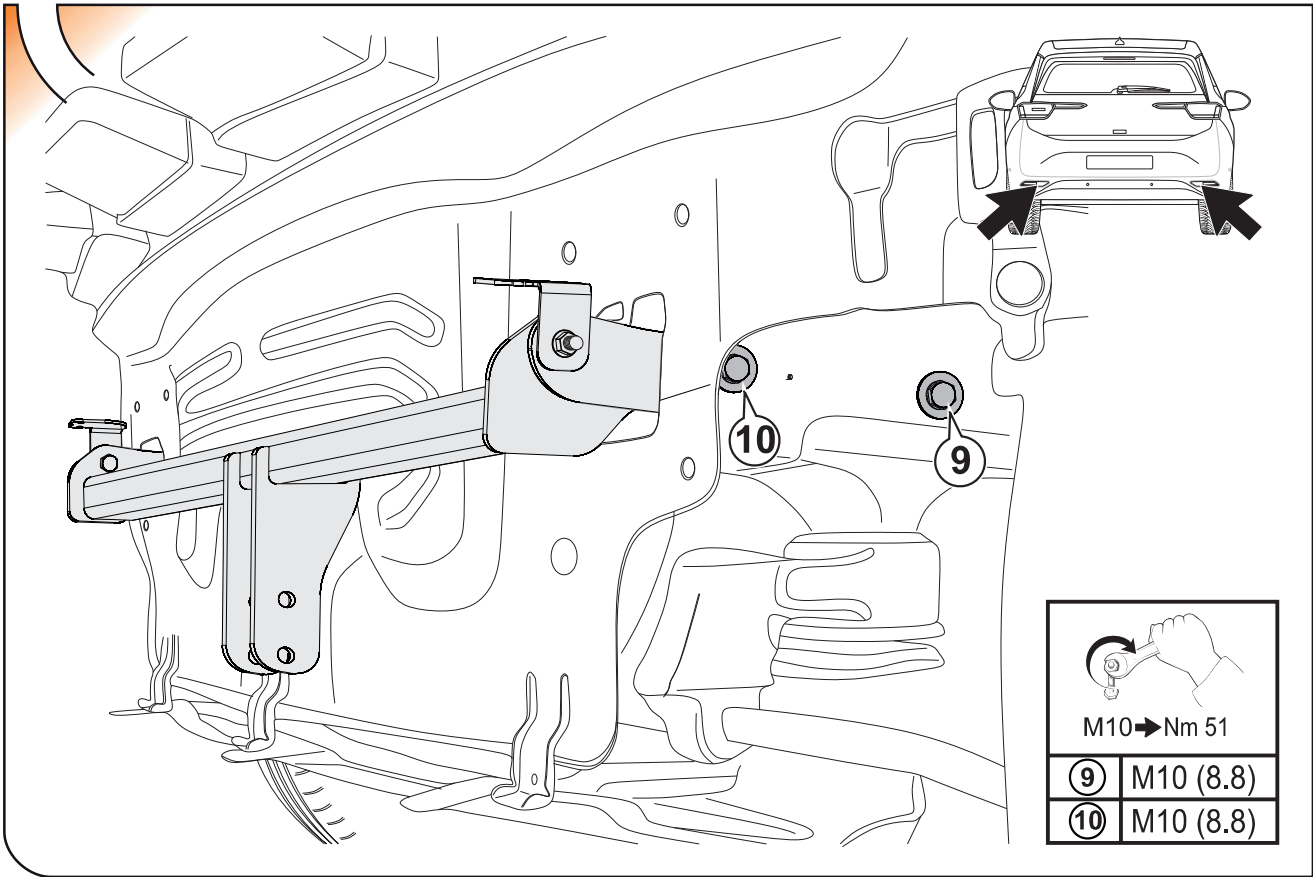

12

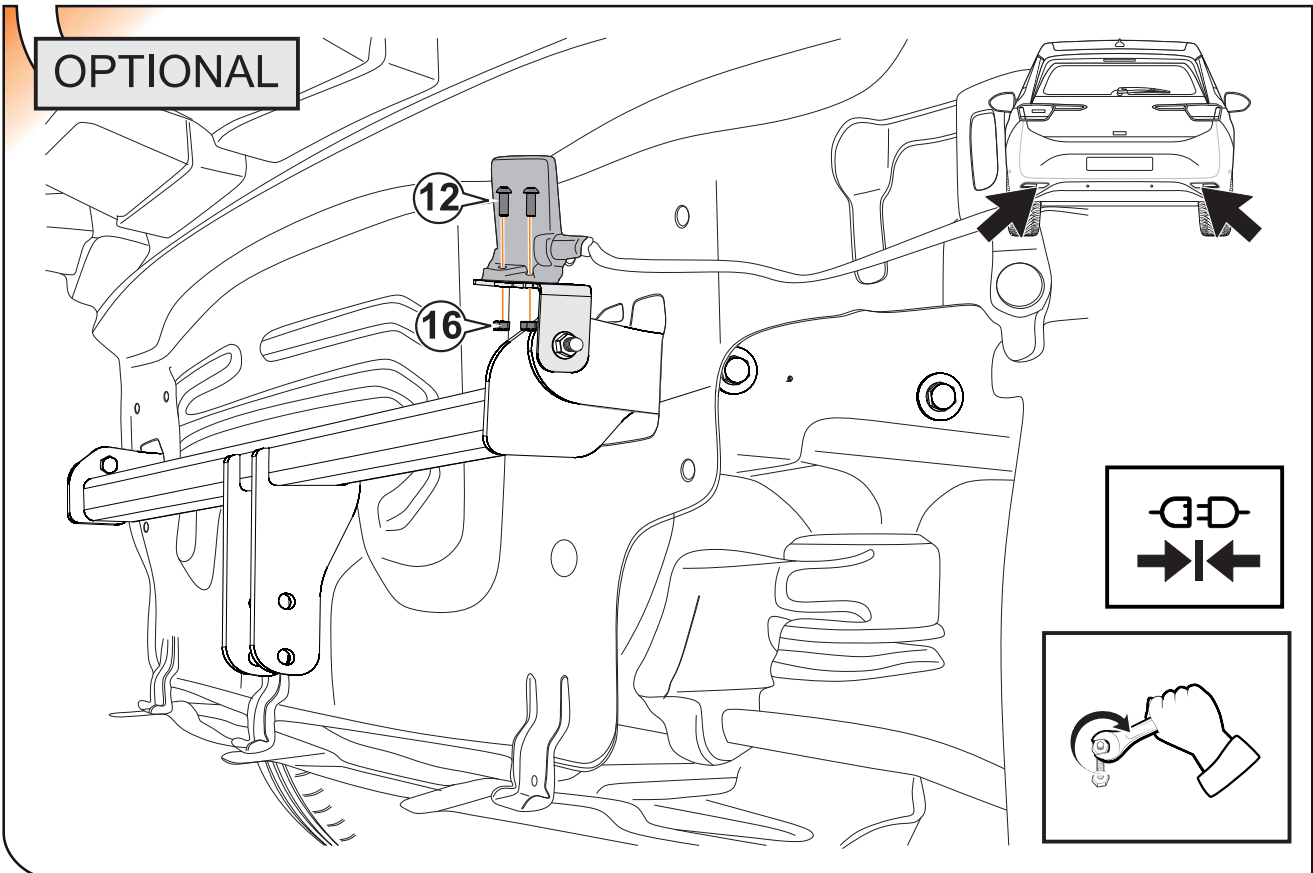



13

### Volkswagen ID.3

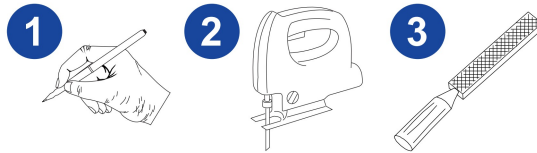
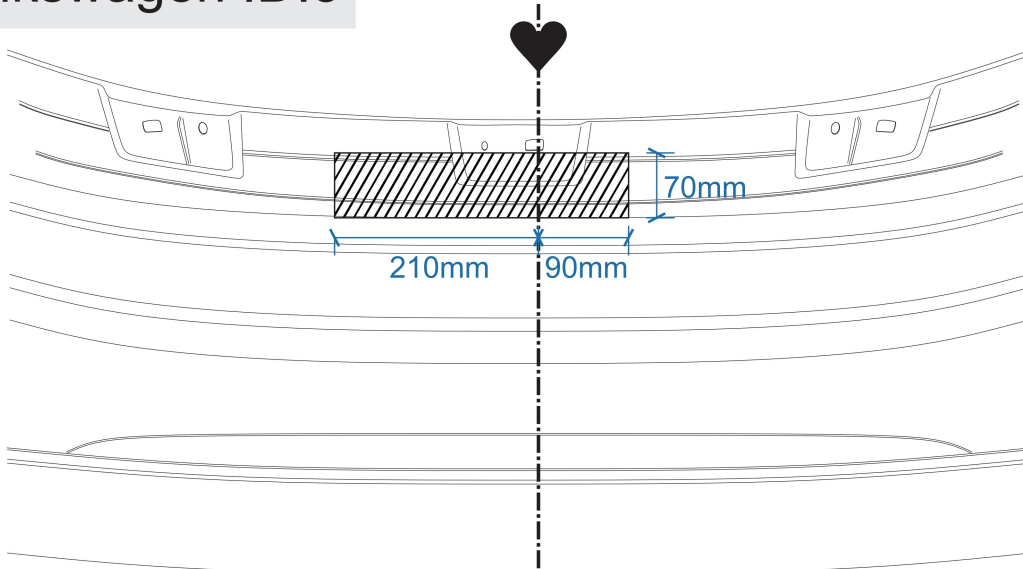

14

### Cupra Born

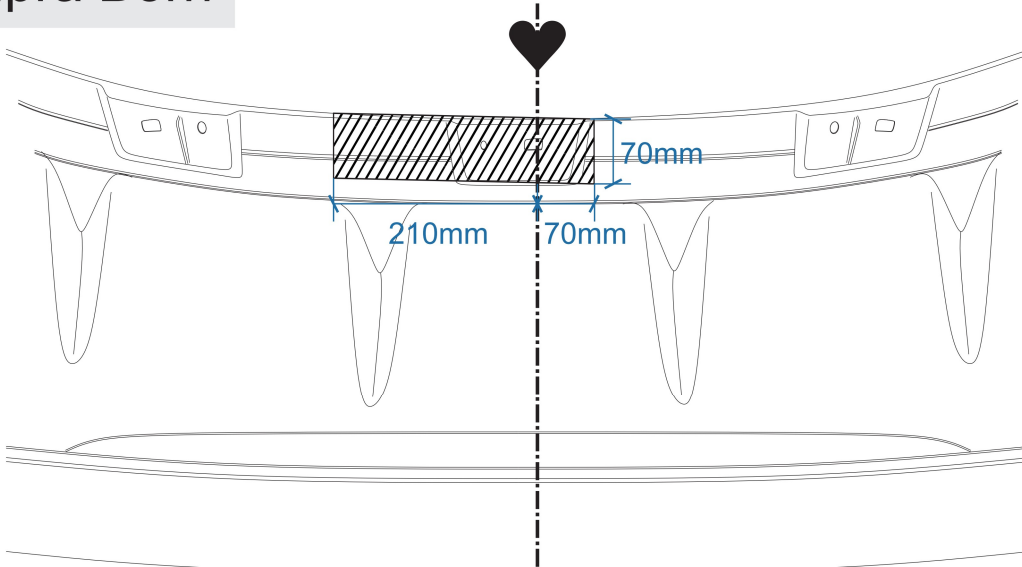

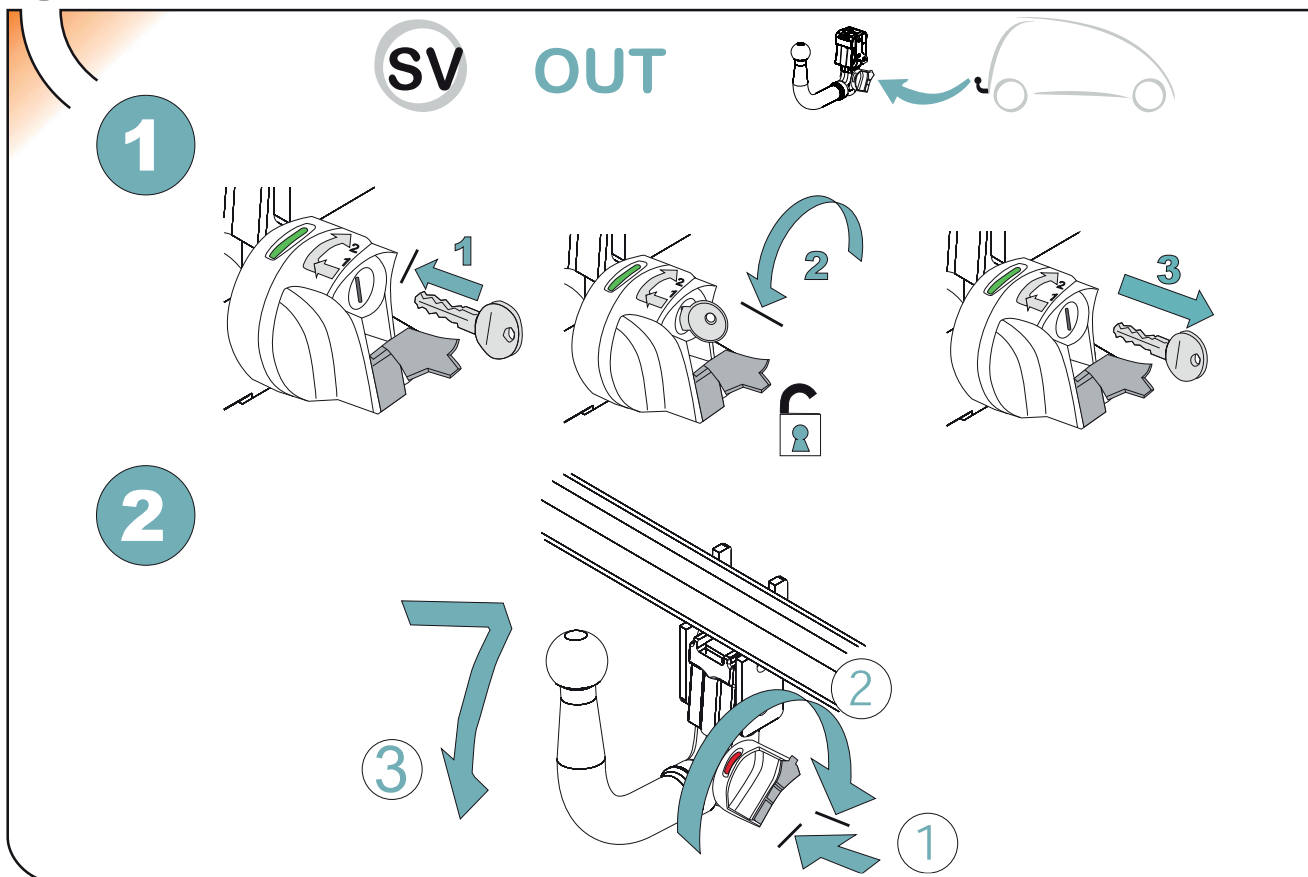
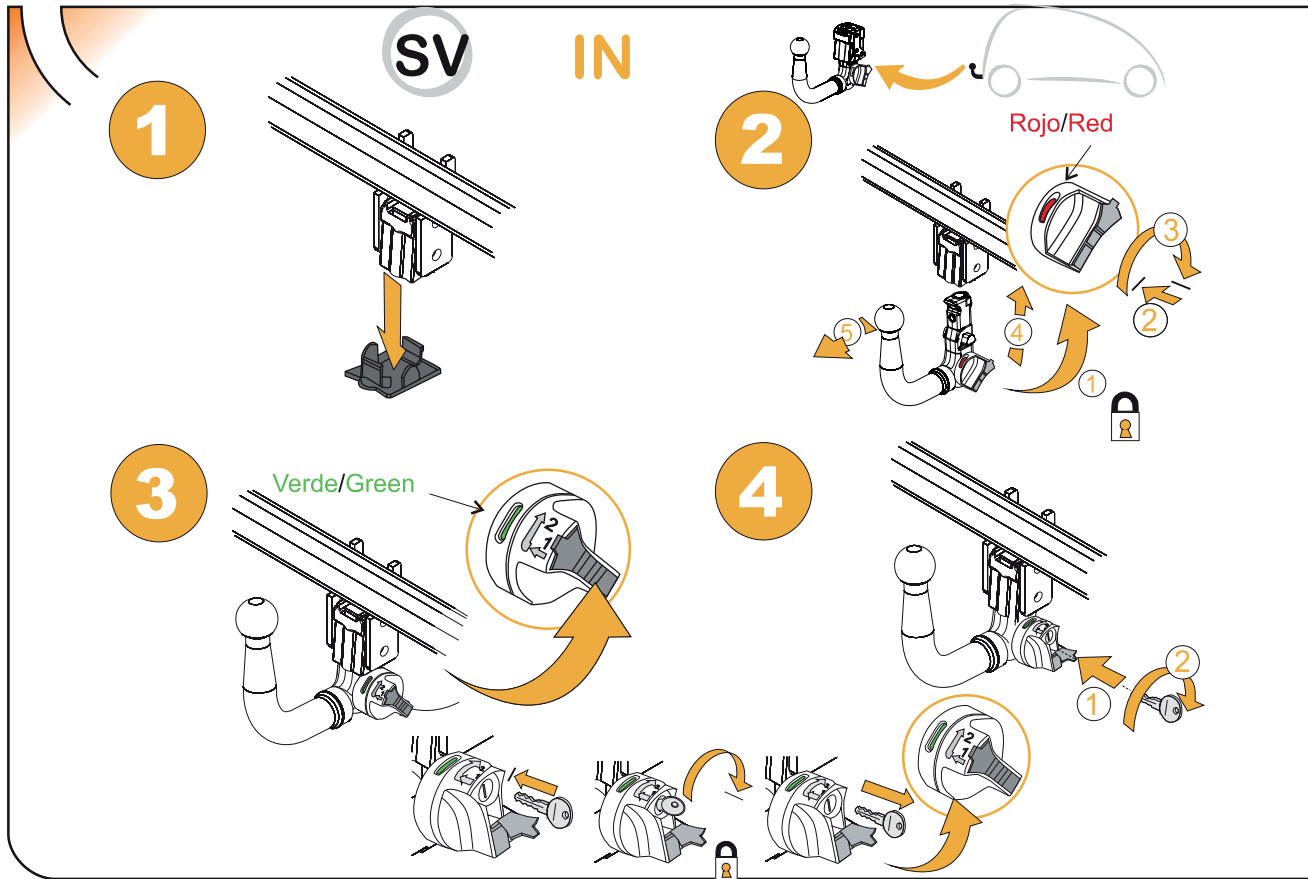

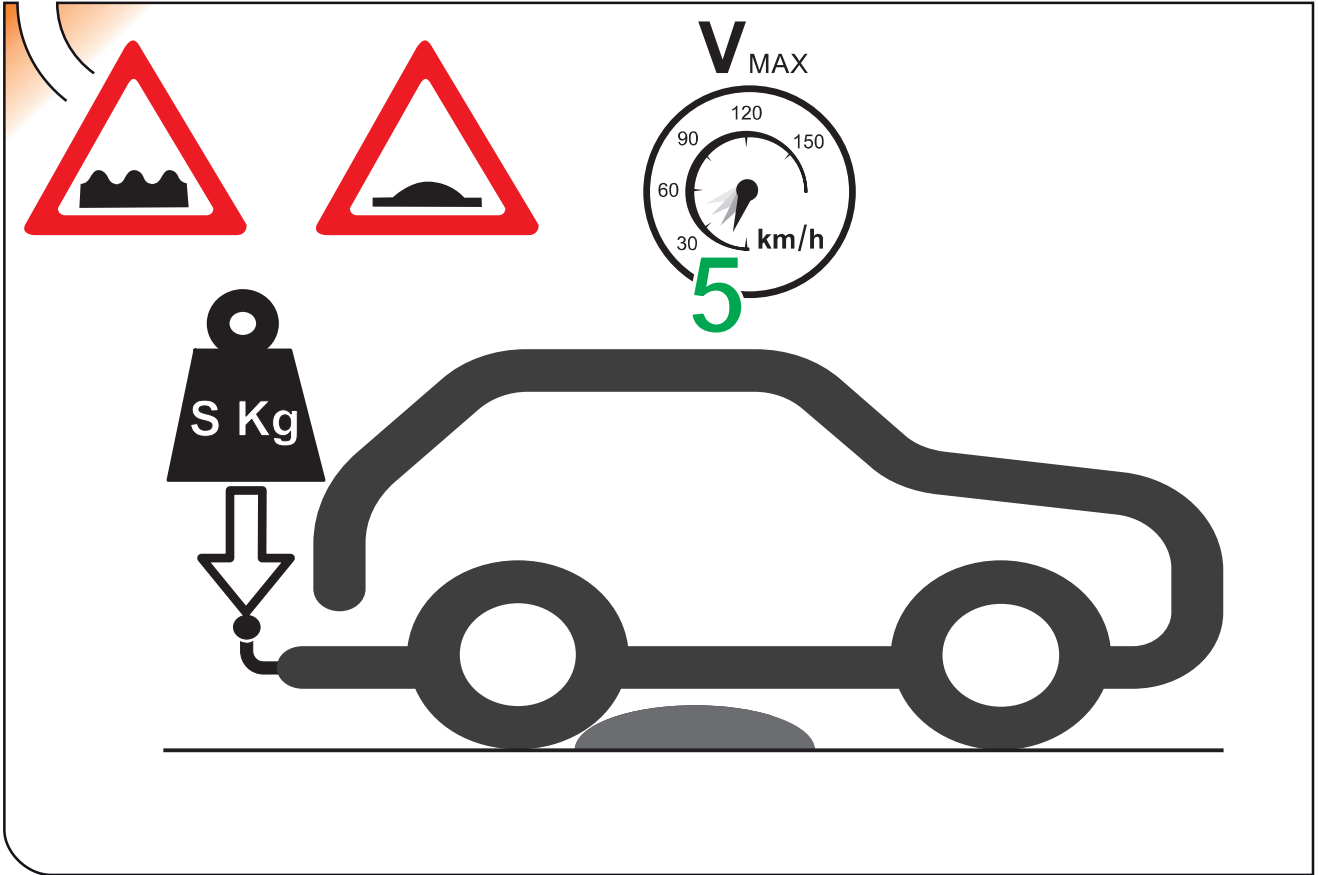



**T**owBox®



enganches  
**aragon**





# ANEXO III

## CERTIFICADO DE TALLER

D. \_\_\_\_\_, expresamente autorizado por la empresa \_\_\_\_\_  
domiciliada en \_\_\_\_\_, teléfono \_\_\_\_\_, dedicada  
a la actividad de \_\_\_\_\_ n° de Registro Industrial \_\_\_\_\_ y n° de registro  
especial (1) \_\_\_\_\_.

### CERTIFICA

Que la mencionada empresa ha realizado la/s Reforma/s y asume la responsabilidad de la ejecución,  
sobre el vehículo marca....., tipo.....  
variante..... denominación comercial .....  
matrícula ..... y n° de bastidor ....., de acuerdo con:

- La normativa vigente en materia de reformas de vehículos.
- Las normas del fabricante del vehículo aplicables a la/s reforma/s llevadas a cabo en dicho vehículo.
- El proyecto descriptivo de la/s reforma/s, adjunto al expediente.

#### OBSERVACIONES: (2)

Tipificada/s con el código de reforma/s.....  
Reforma consiste en:

#### COLOCACION DE ENGANCHE HOMOLOGADO EUROPEO MARCA:

\_\_\_\_\_

n° de identificación / marca de homologación:

Type :

Garantizo que se cumple lo previsto en el artículo 6 del Reglamento General de vehículos y, en su caso, en el artículo 9 del R.D. 1457/1986, de 10 de enero, por el que se regula la actividad industrial en talleres de vehículos automóviles, de equipos y sus componentes, modificado por 455/2010 de 16 de abril.

....., a.....de.....de .....

Firma y sello:

(1) En el caso de que la reforma sea efectuada por el fabricante se indicará N/A.

(2) Se debe especificar en este apartado OBSERVACIONES, la identificación de los equipos o sistemas modificados.

ES

1



2



3



IT

1

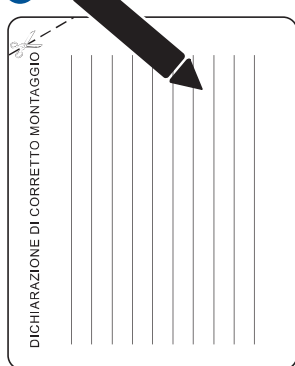

2

