

Lexus NX (2015-)

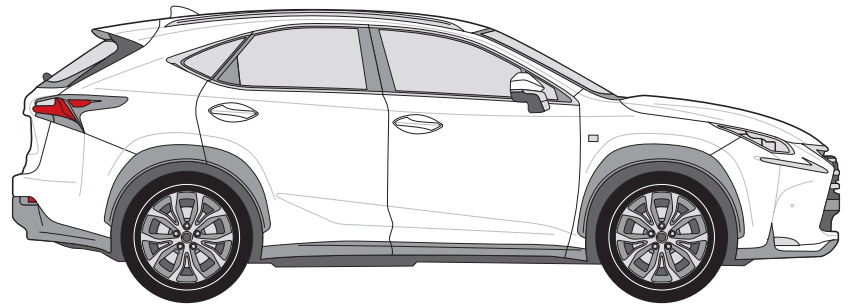

R55

Lexus NX (2015-)

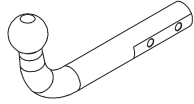

TowCar **aragon** enganches

E13 APPROVALNUMBER D D-VALUE
 55R-01 4479 9,1 kN

TYPE CLASS MAX.VERT.LOAD
 LEX006 A50-X S 111 kg

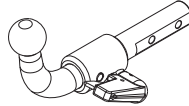

TowCar **aragon** enganches

E13 APPROVALNUMBER D D-VALUE
 55R-01 4480 9,1 kN

TYPE CLASS MAX.VERT.LOAD
 LEX007 A50-X S 111 kg

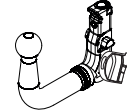

TowCar **aragon** enganches

E13 APPROVALNUMBER D D-VALUE
 55R-01 4480 9,1 kN

TYPE CLASS MAX.VERT.LOAD
 LEX007 A50-X S 111 kg

D=9,1 kN



S= 111 kg

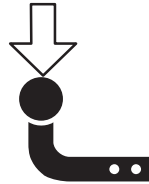

*T 1500 Kg



N/m	8,8	10,9	12,9
M6	10	15	18
M8	24	36	42
M10	51	75	87
M12	87	130	147
M14	138	198	231
M16	200	289	341

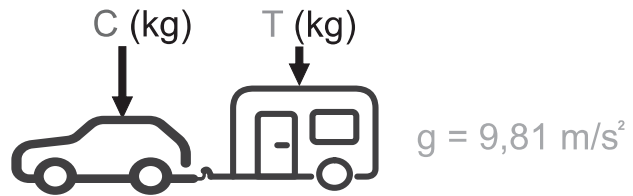

$$D \geq \frac{T \cdot C}{T+C} \cdot \frac{g}{1000} \text{ (kN)}$$

$$T \leq \frac{C \cdot D \cdot 1000}{(C \cdot g) - (1000 \cdot D)} \text{ (kg)}$$

*El MMR (T) puede variar dependiendo del vehículo.

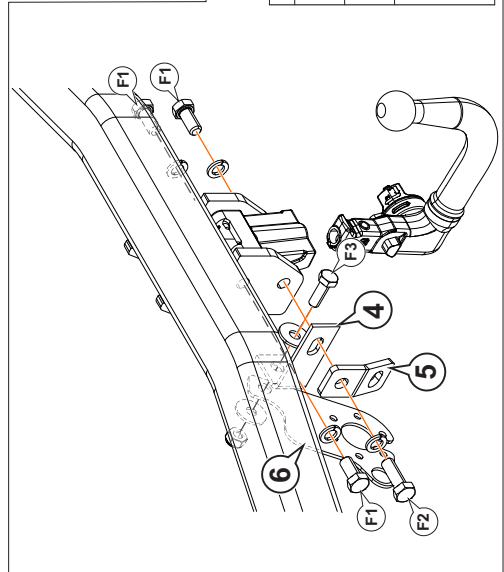
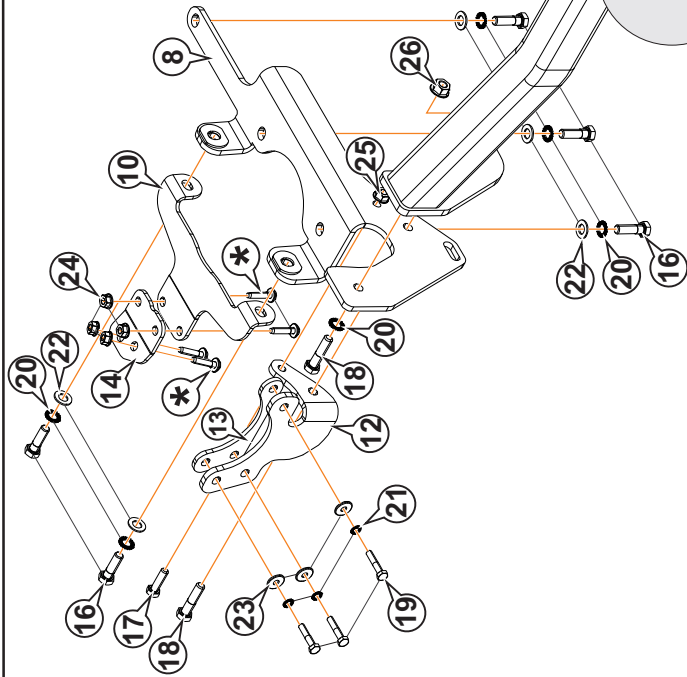
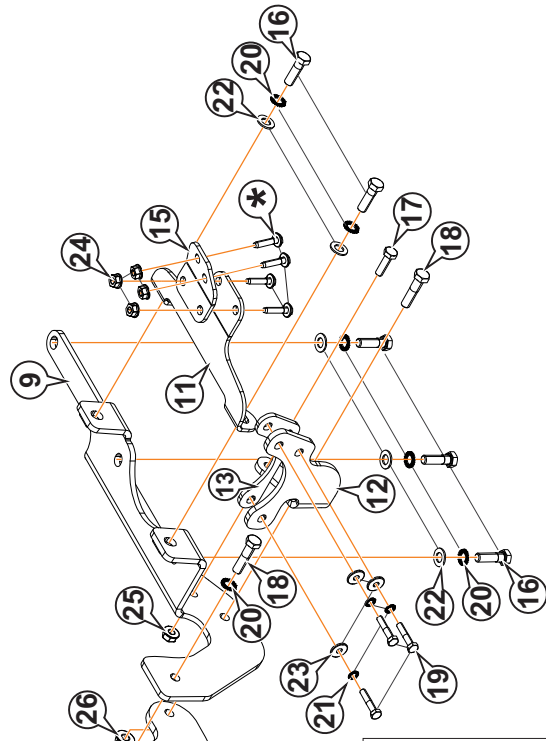
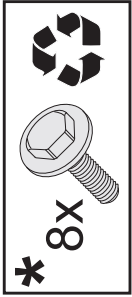
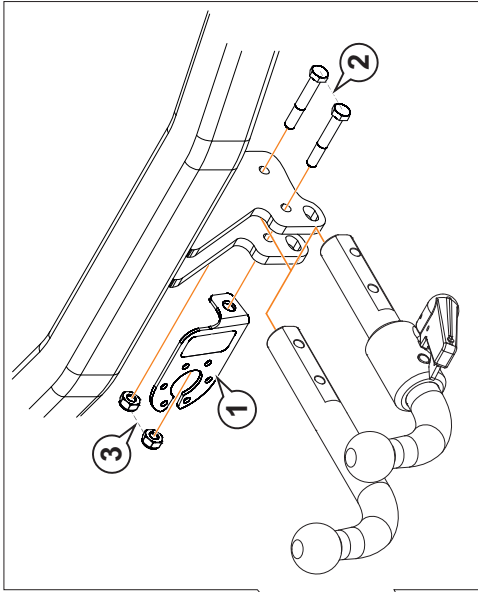

	#
F1	M12 x 25 DIN 933
	3
	Ø12 Grover DIN 128
	3
F2	M12 x 35 DIN 933
	3
	Ø12 Grover DIN 128
	1
	M10 x 30 DIN 933
	1
F3	Ø10 Poluretano / Nylon
	1
	Ø10 DIN 9021
	1
	M10 DIN 980
	1

				
1		AEV0005	1	
2		M10x65 DIN 931	2	
3		M10 DIN 980	2	
4		AEV0006		1
5		SR844404		1
6		AEV0009		1
7		C3403AA60	1	1
8		C3403AA21	1	1
9		C3403AA22	1	1
10		C3403AA27	1	1
11		C3403AA25	1	1
12		C3403AA23	1+1	1+1
13		C3403AA30	2	2
14		C3403AA28	1	1
15		C3403AA26	1	1
16		M12x1.25x40 DIN 961	10	10
17		M10x35 DIN 933	2	2
18		M12x50 DIN 933	4	4
19		M8x40 DIN 931	6	6
20		Ø12 DIN 128A	12	12
21		Ø8 DIN 128A	6	6
22		Ø12 DIN 125	10	10
23		Ø8 DIN 9021	6	6
24		M8 DIN 6923	8	8
25		M10 DIN 6923	2	2
26		M12 DIN 6923	2	2

1



5 min.

Tel.: (+34) 976 457 130

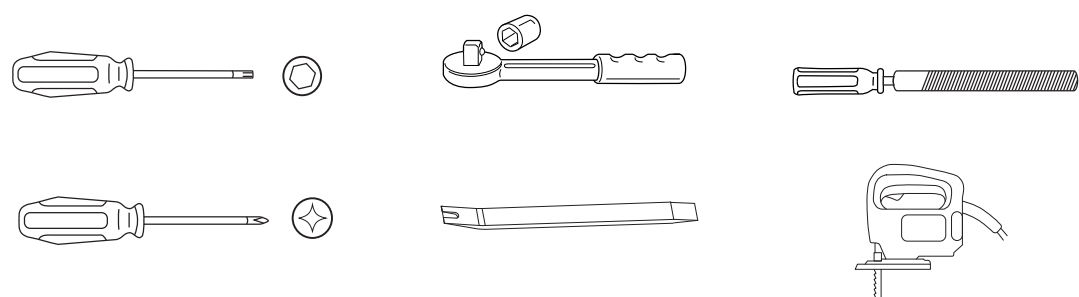

2

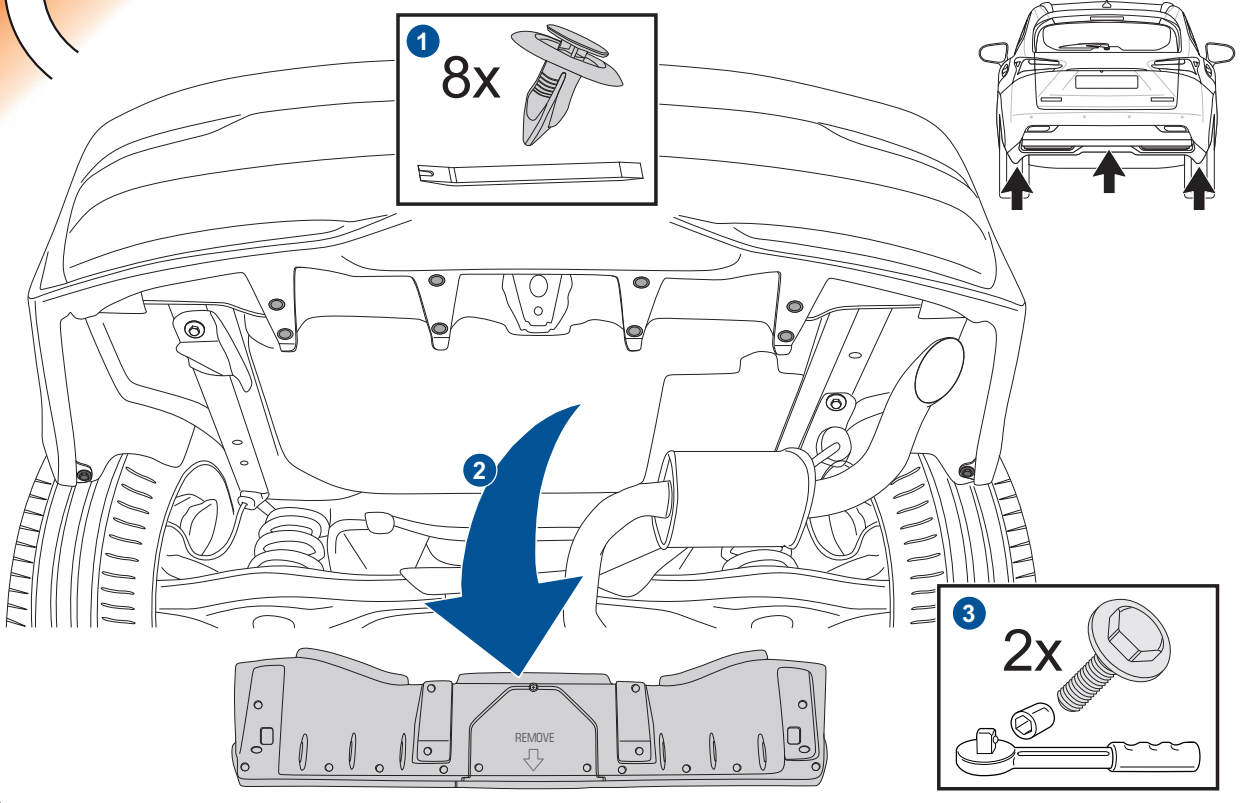

1 8x

2 REMOVE ↓

3 2x

3

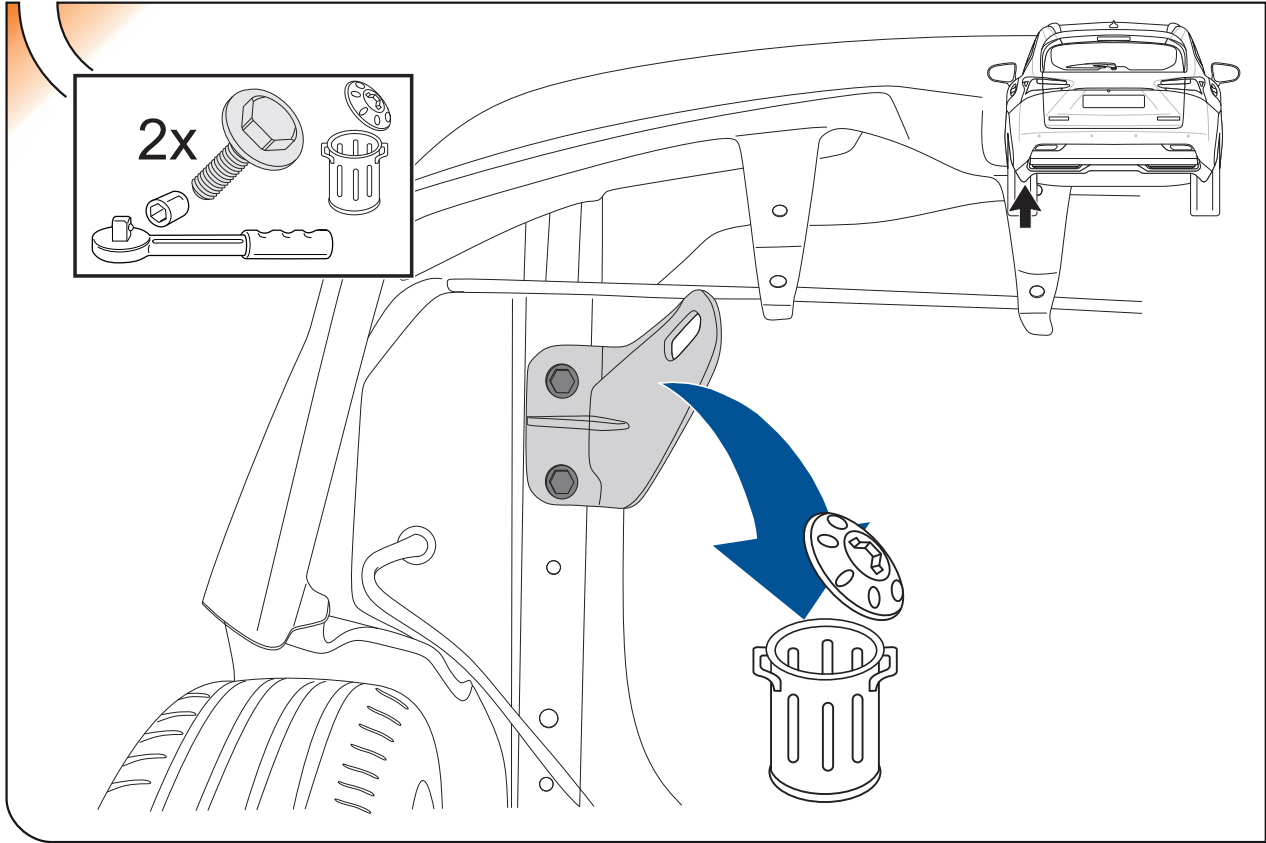

4

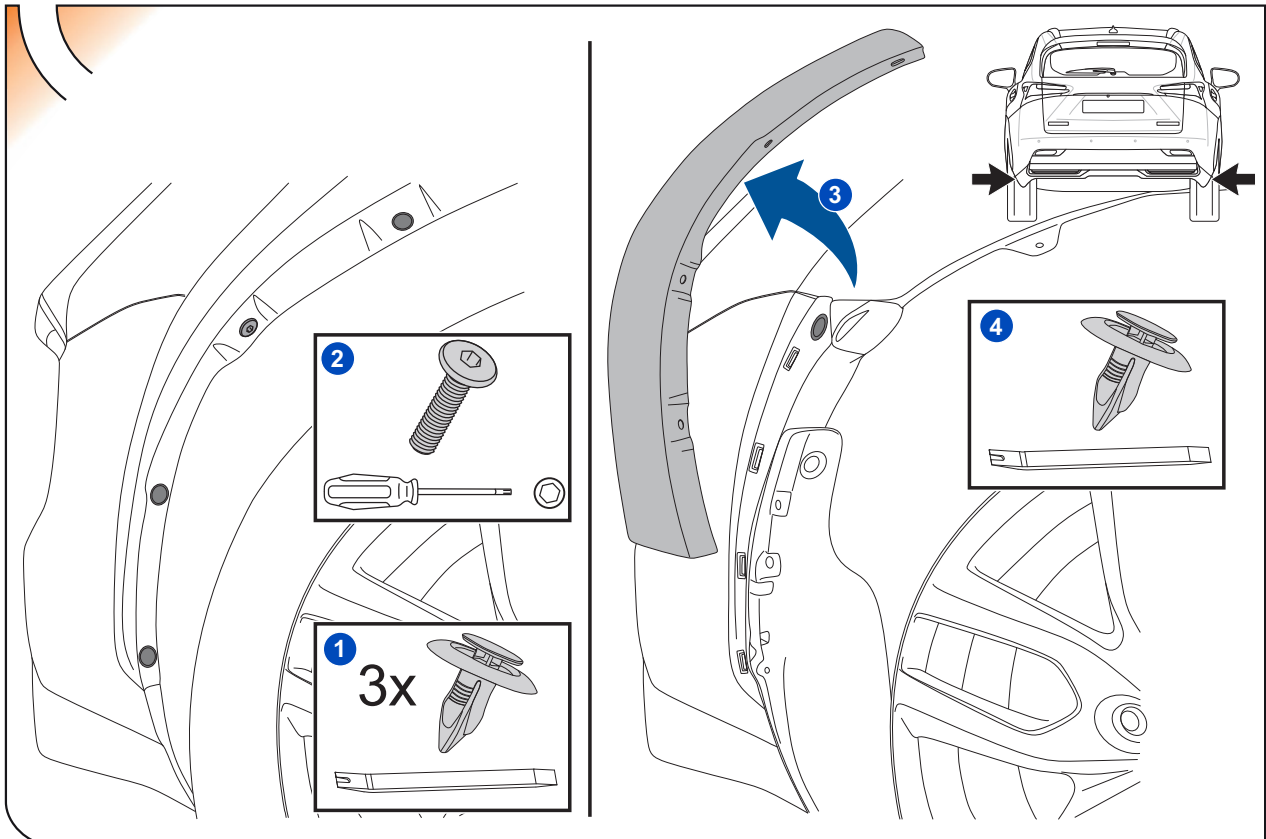

5

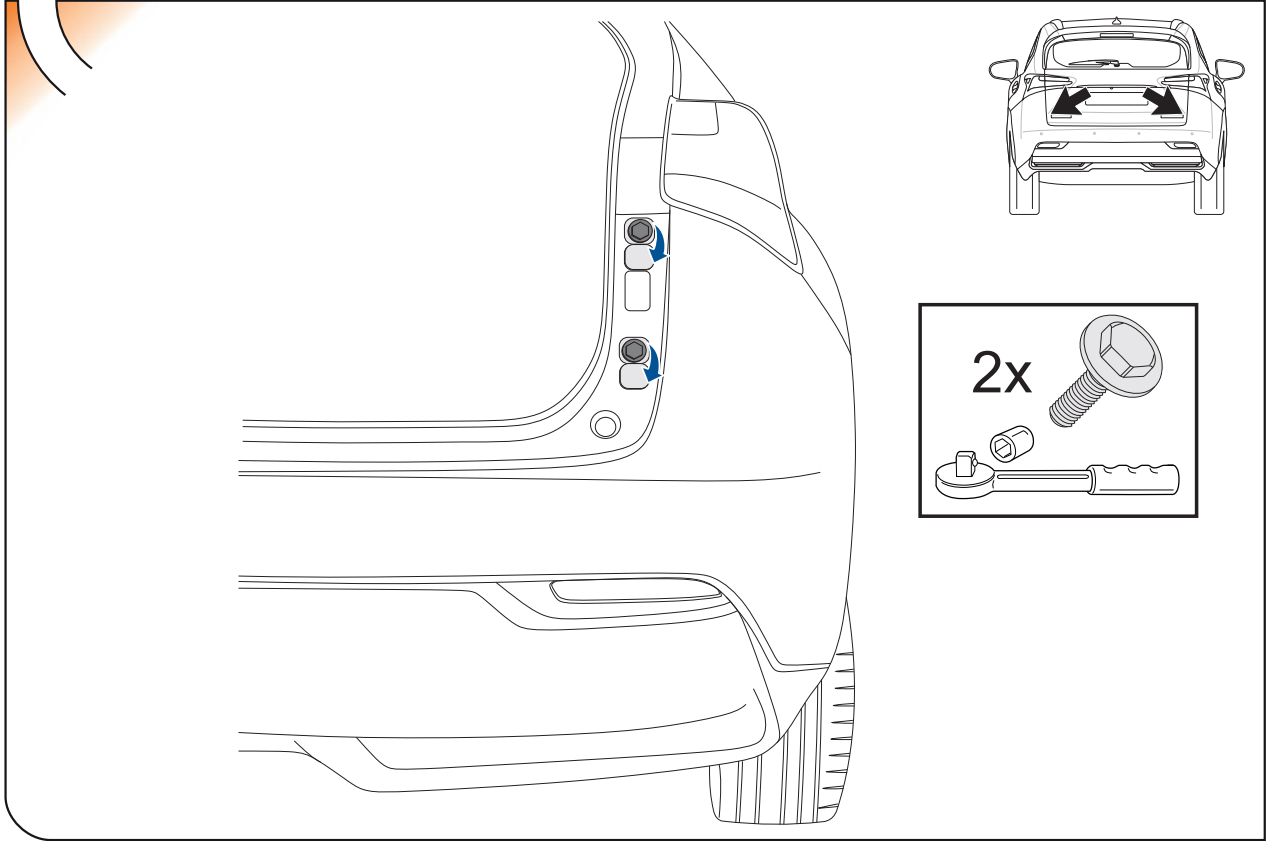

6

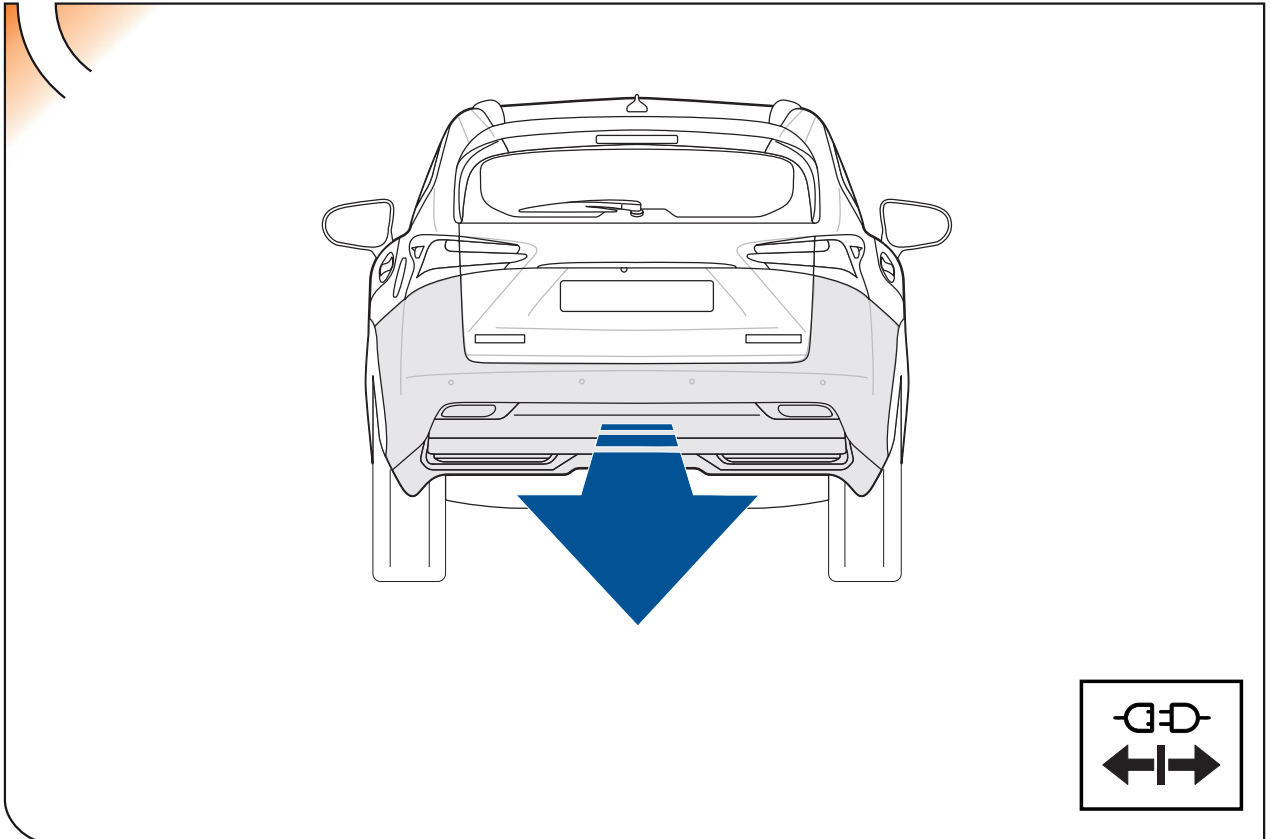

7

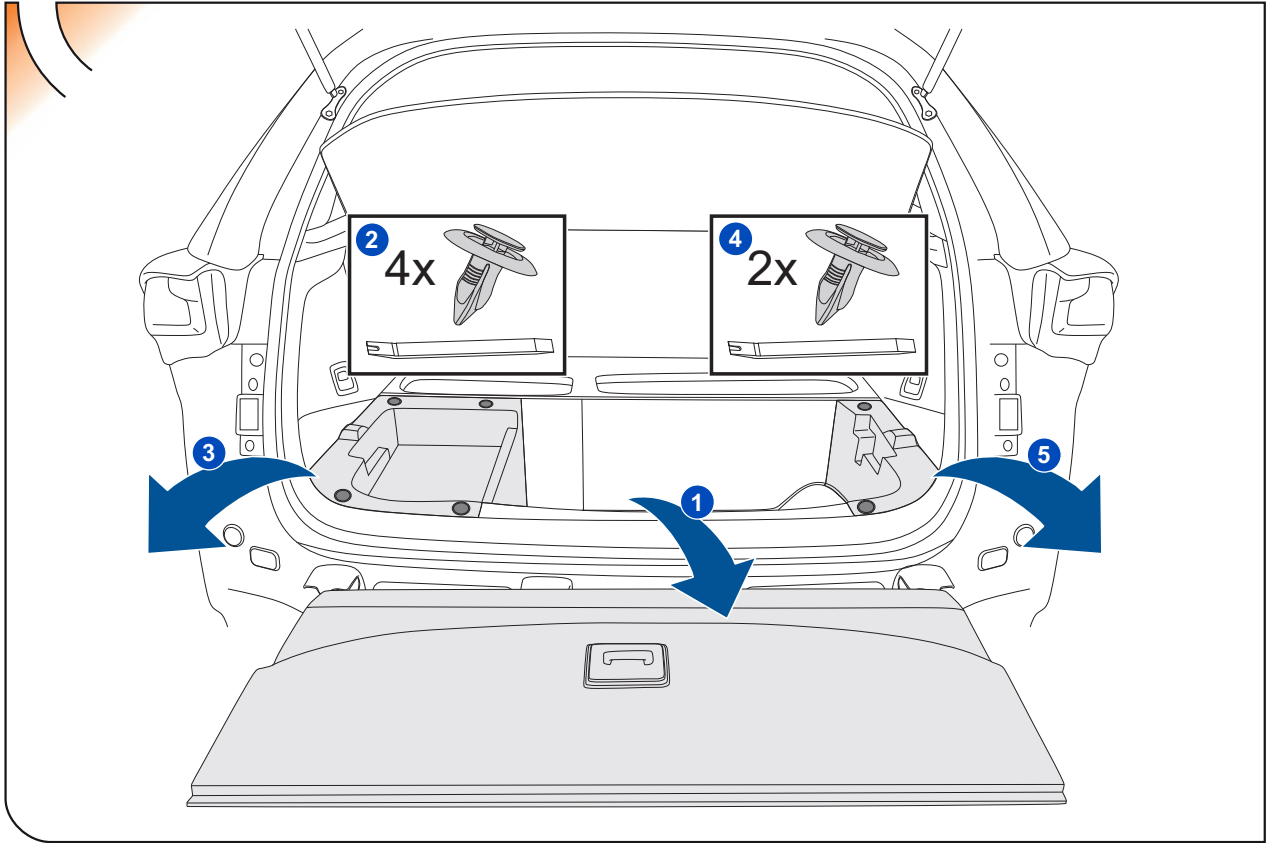

8

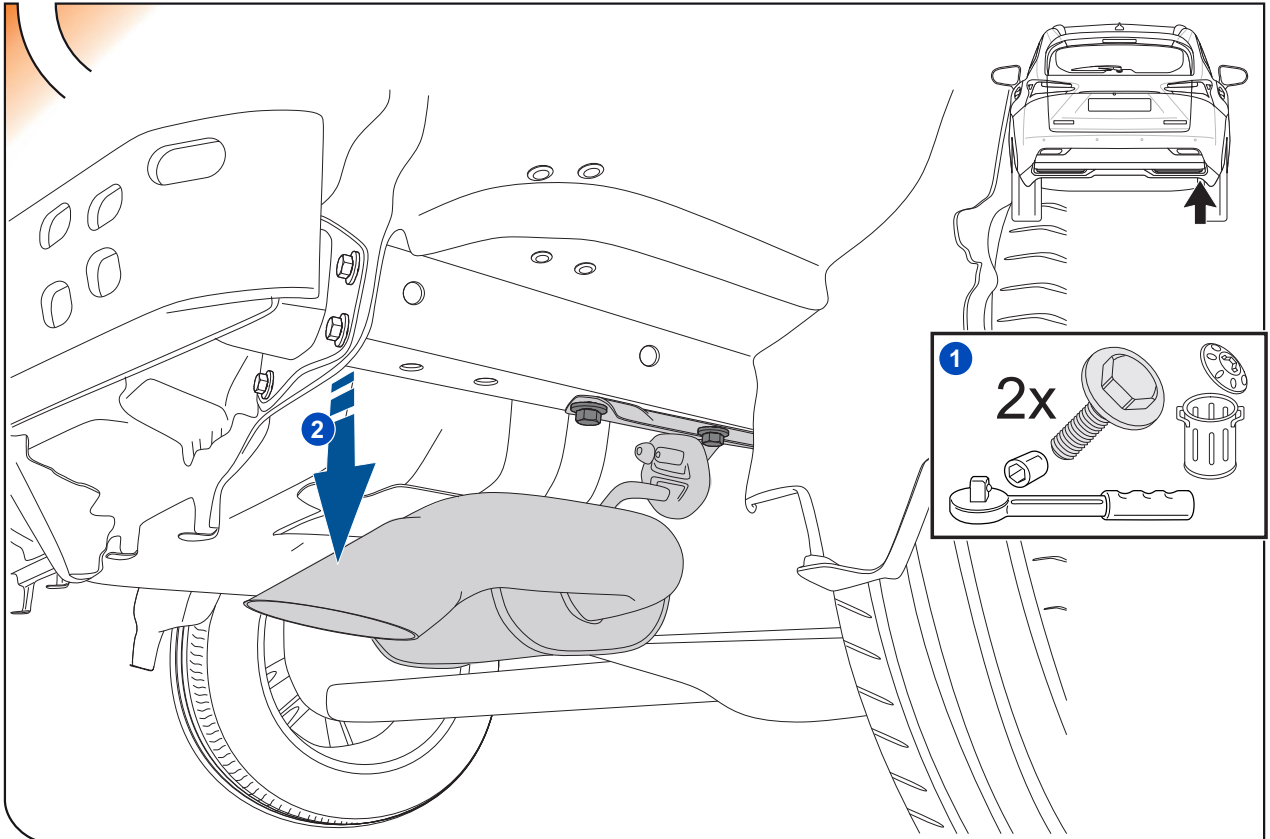

9

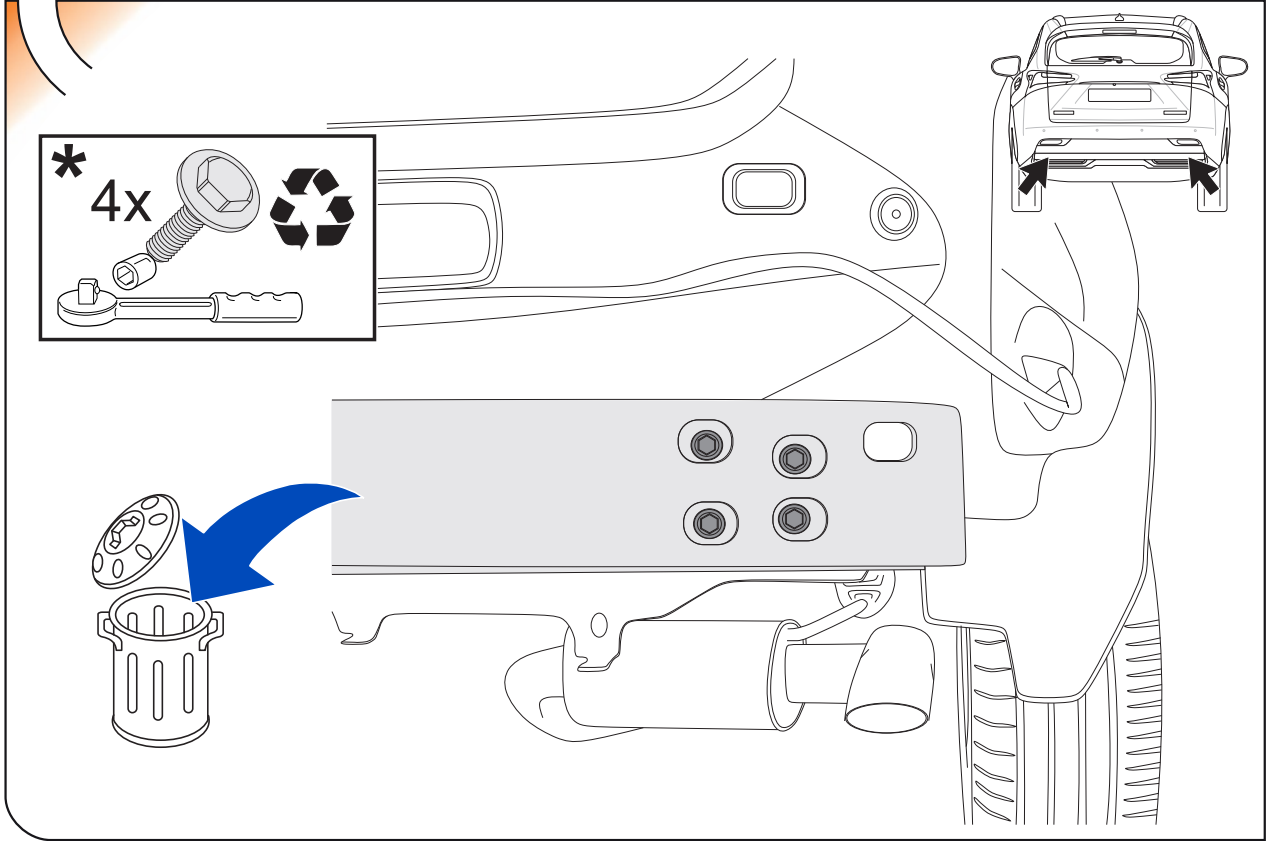

10

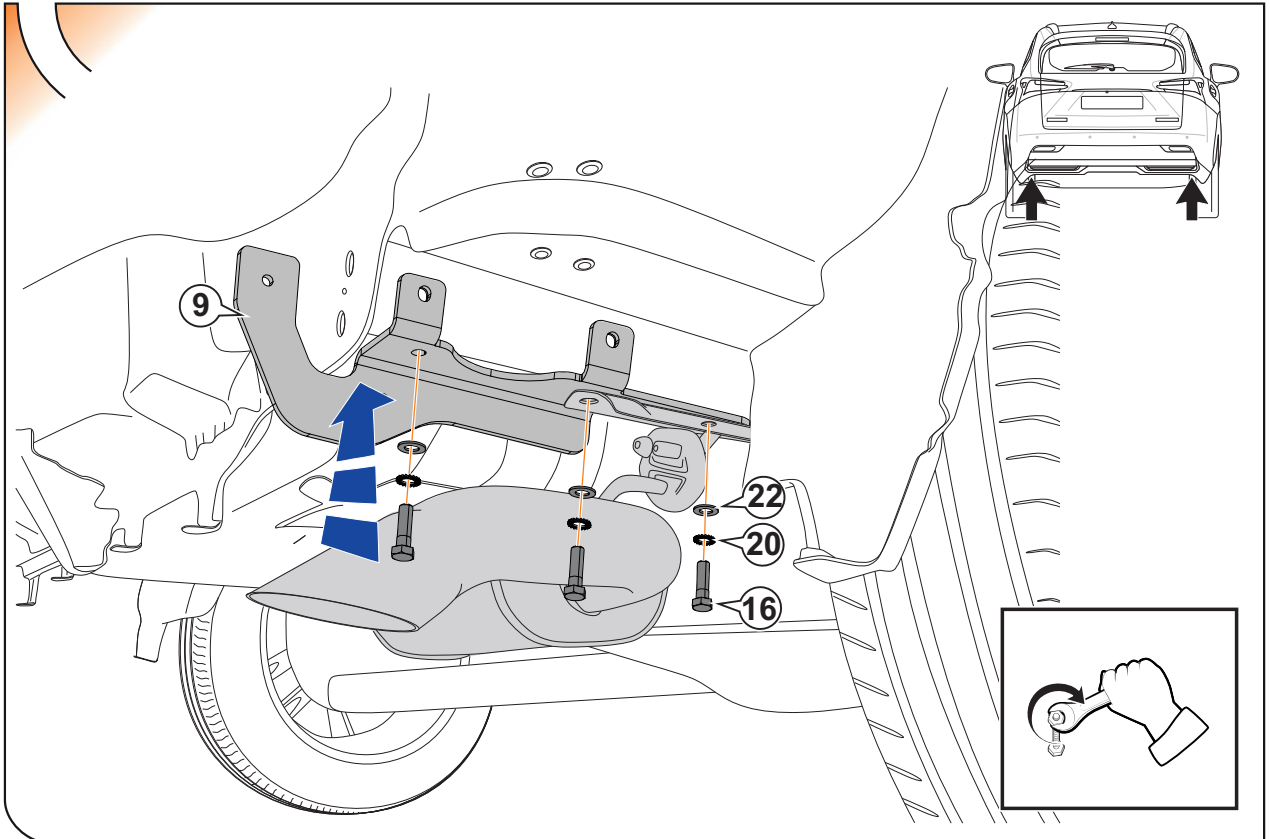

11

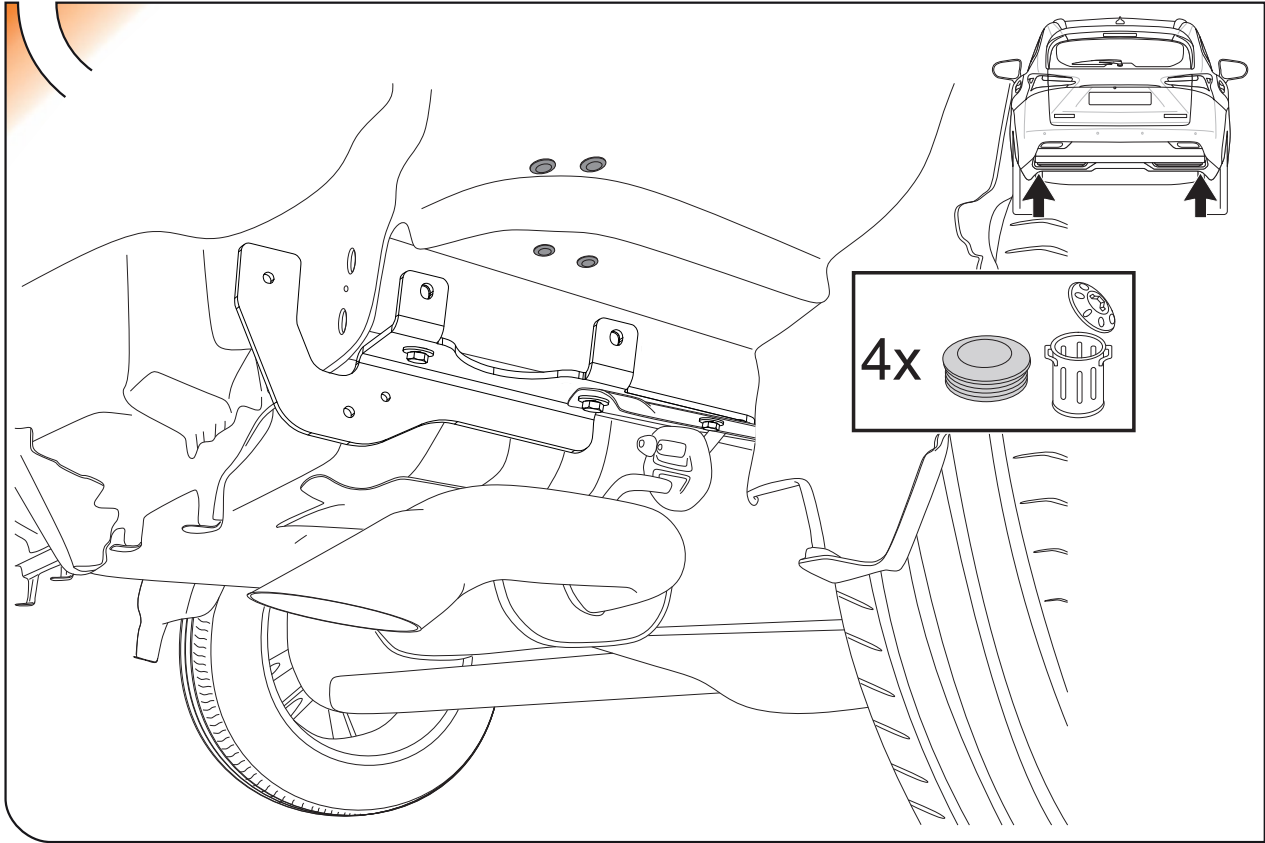

12

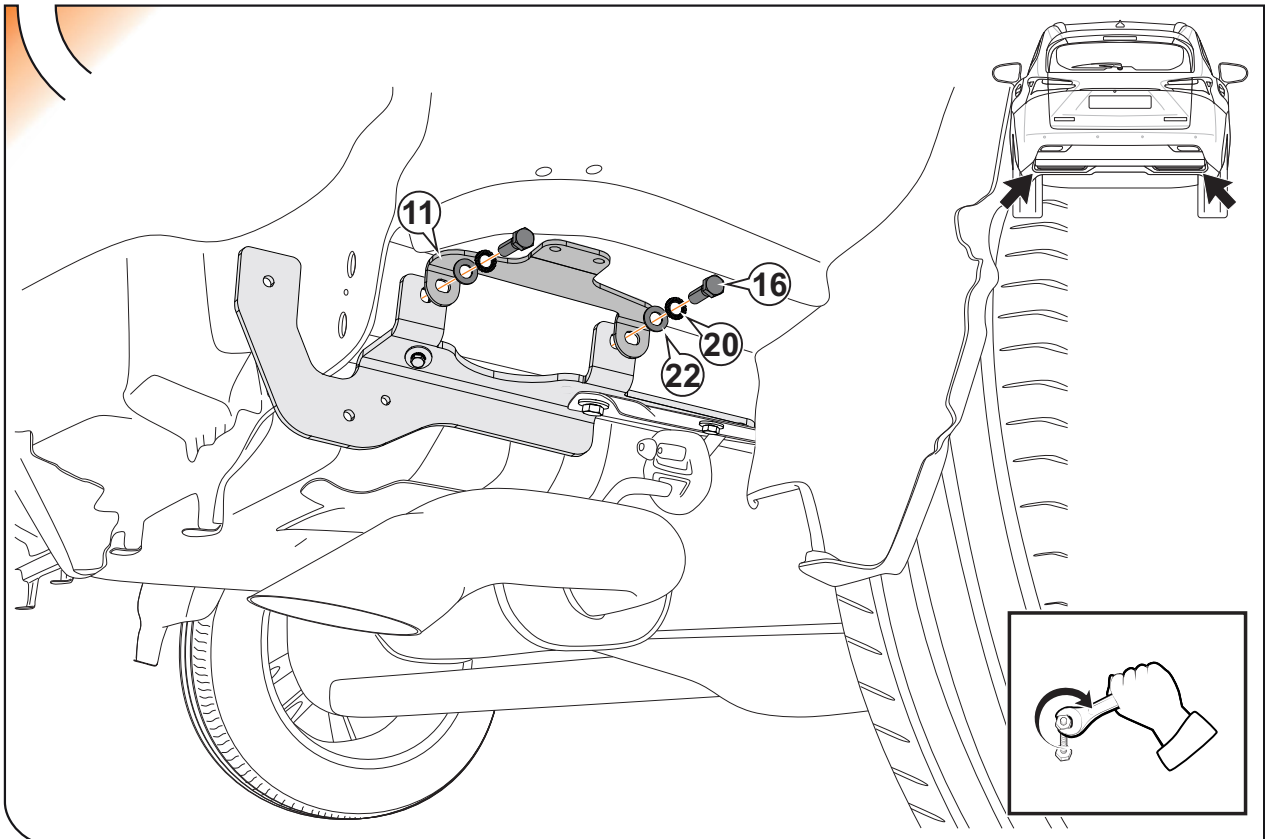

13

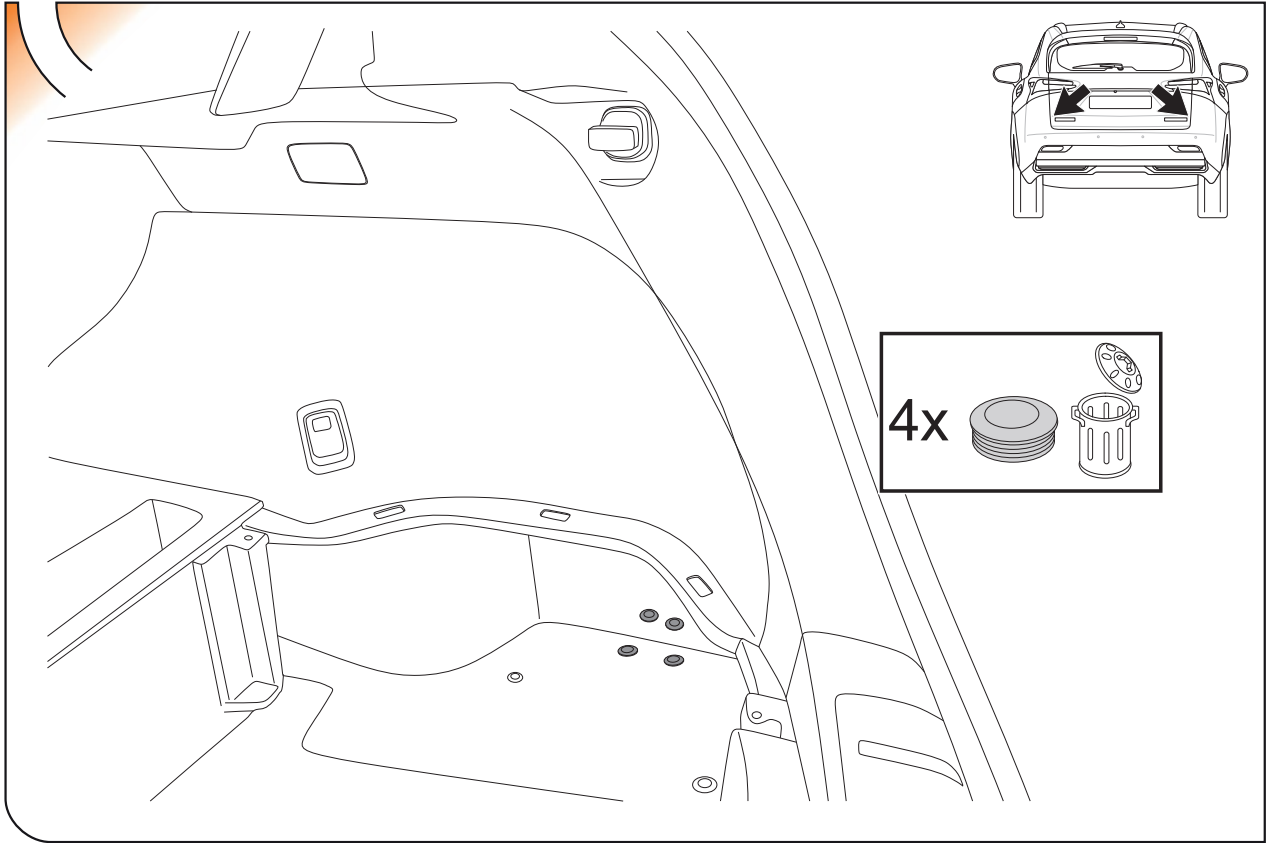

14

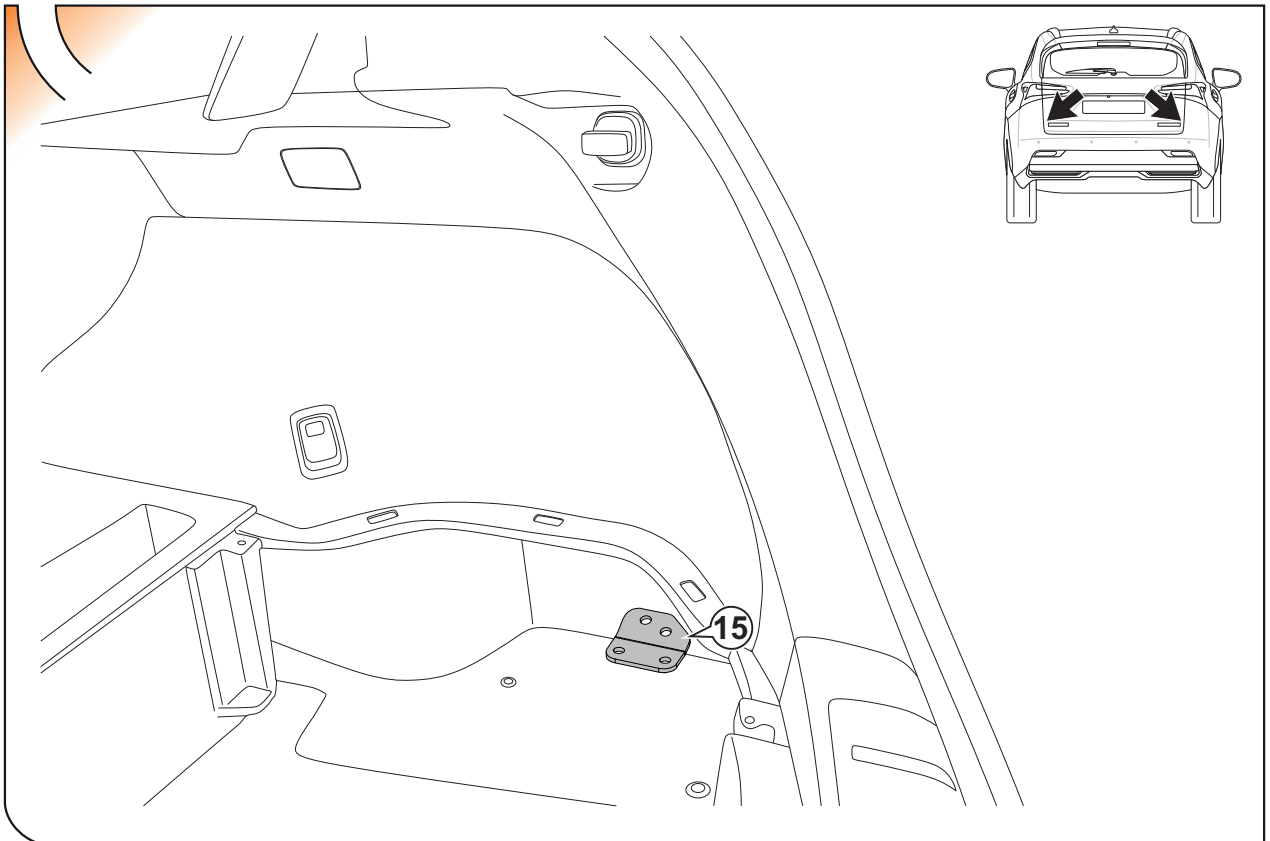

15

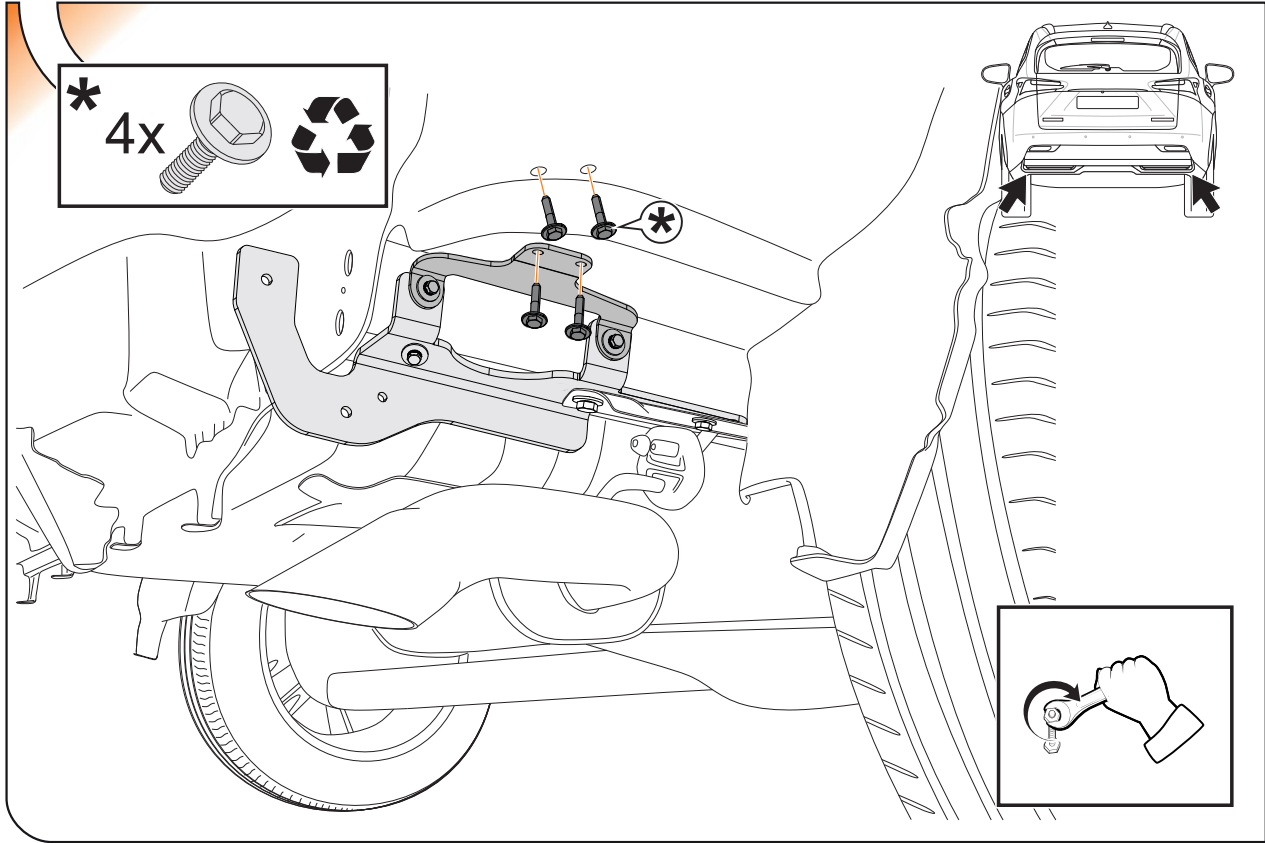

16

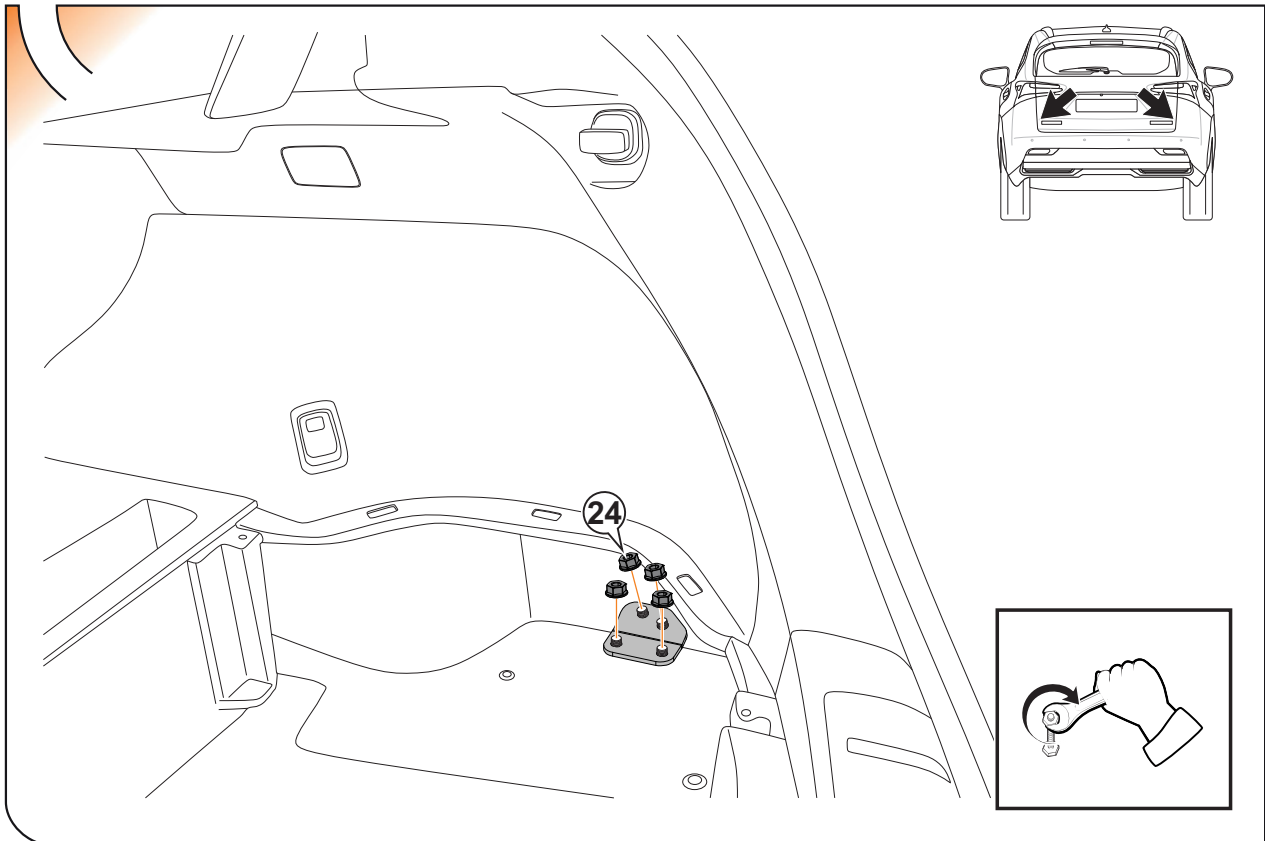

17

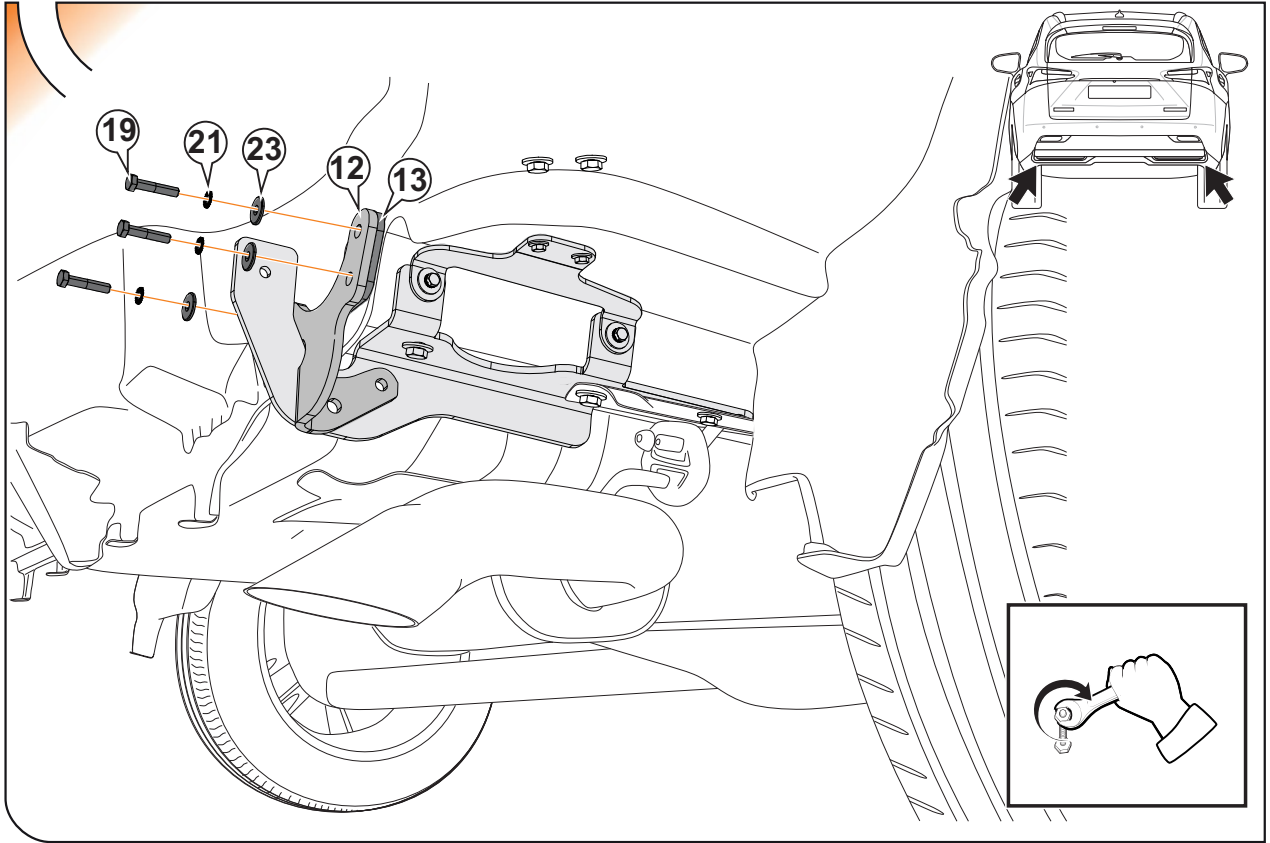

18

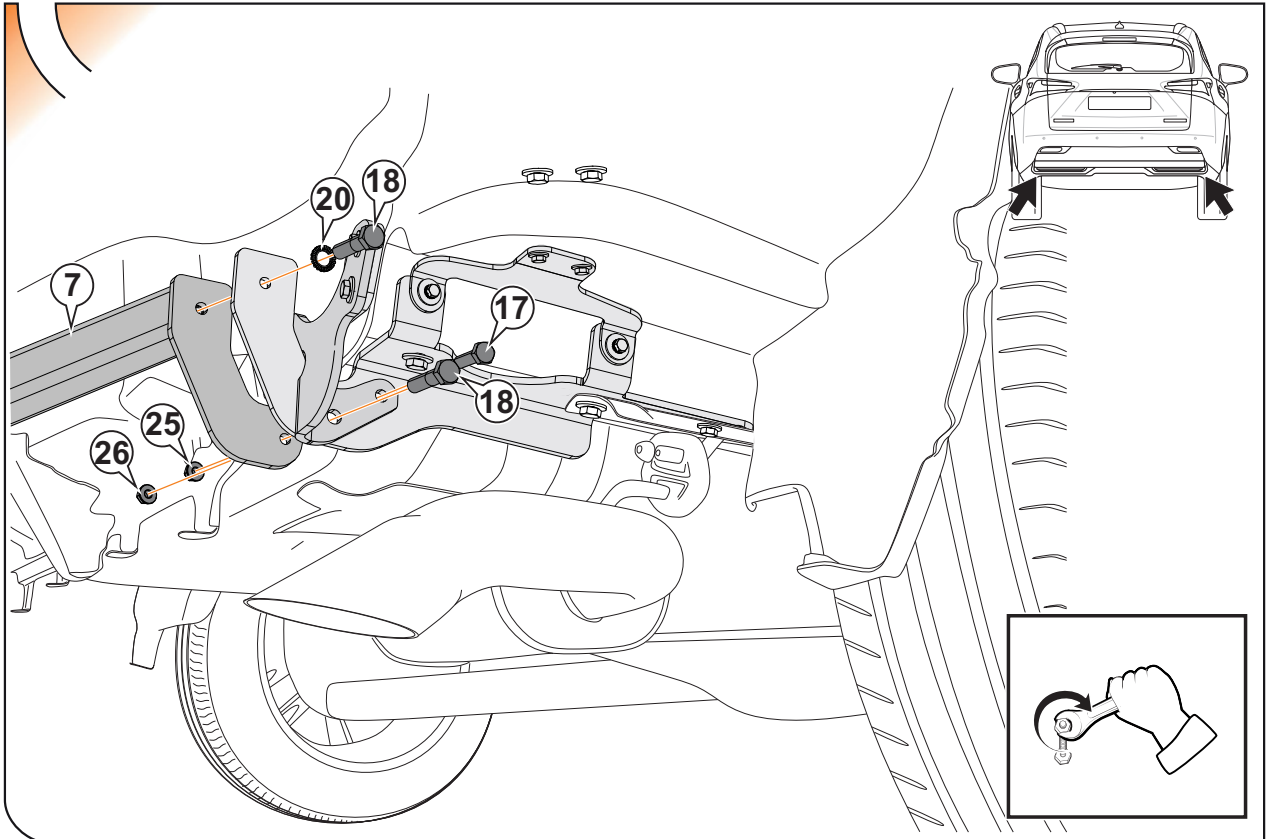

19

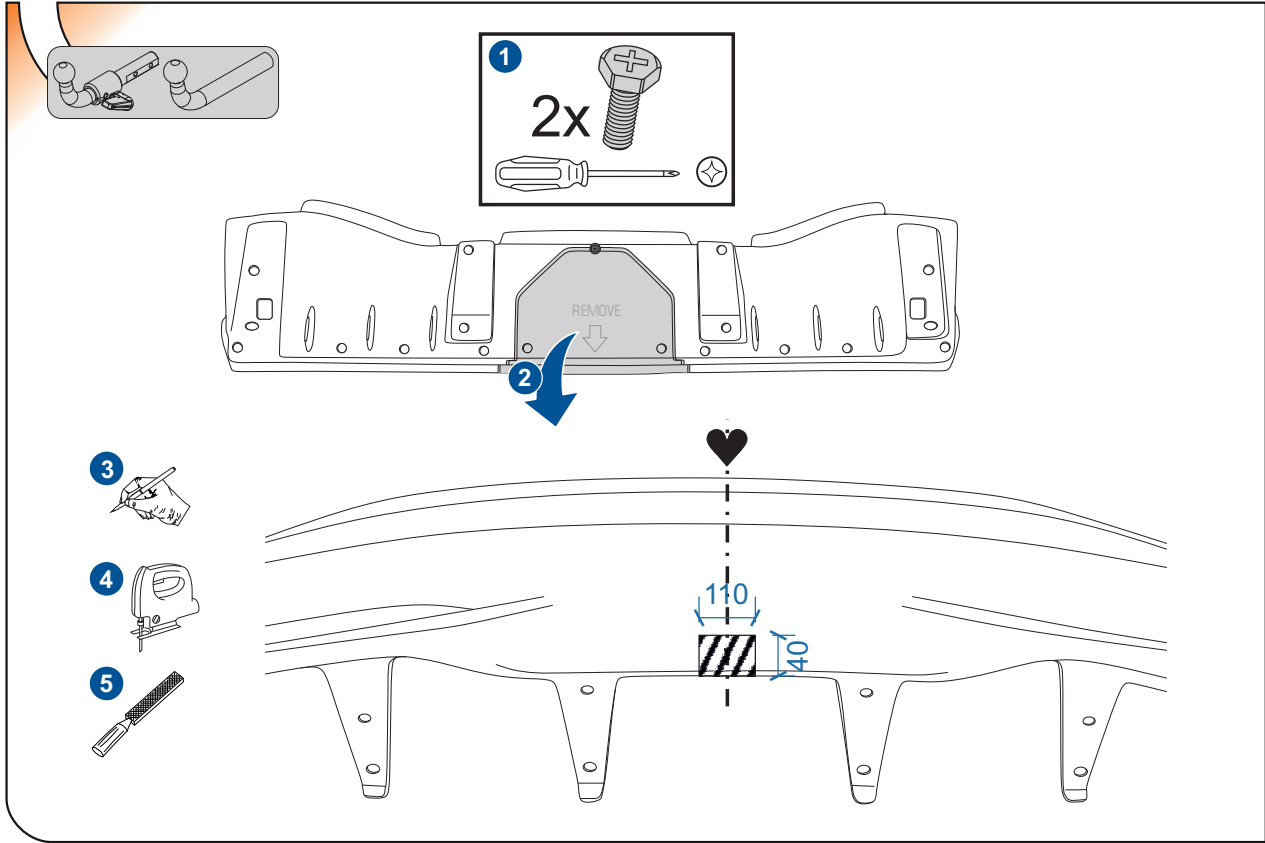

20

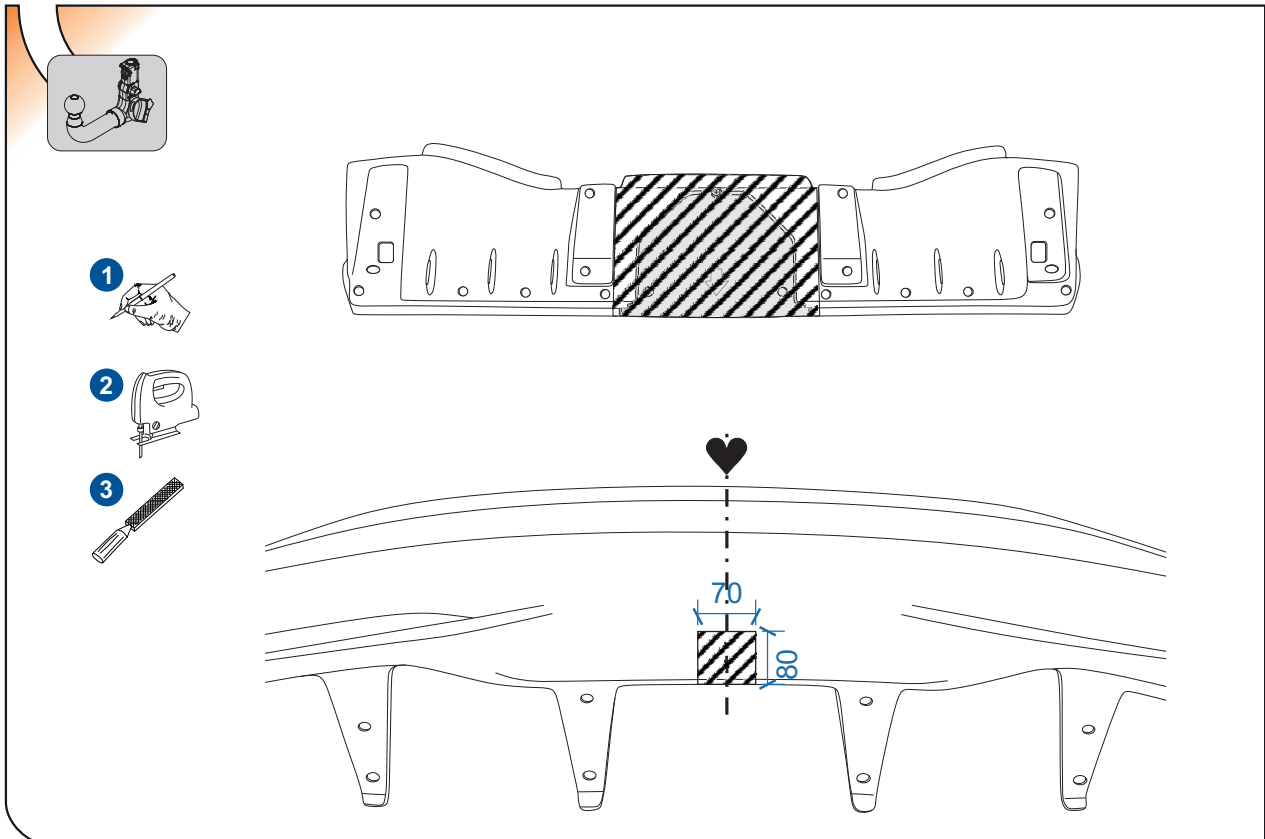

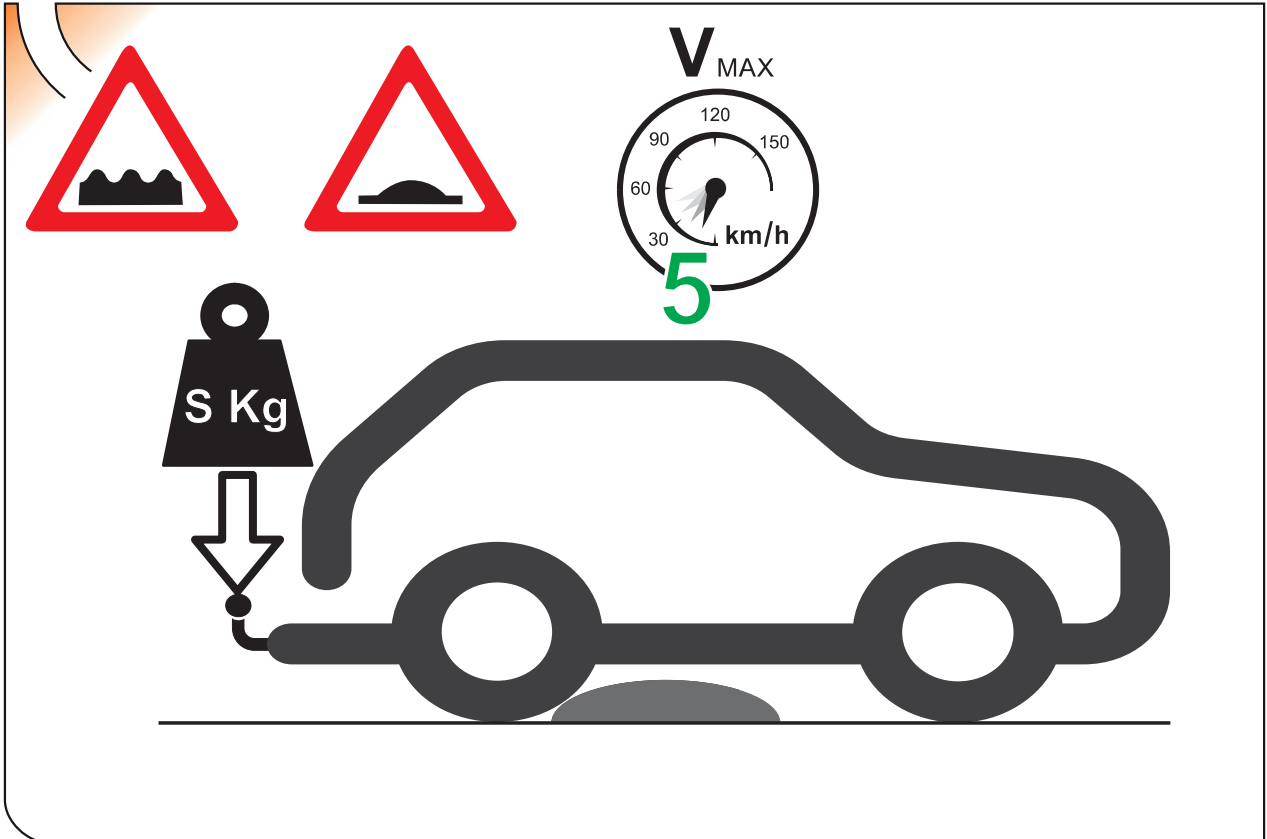
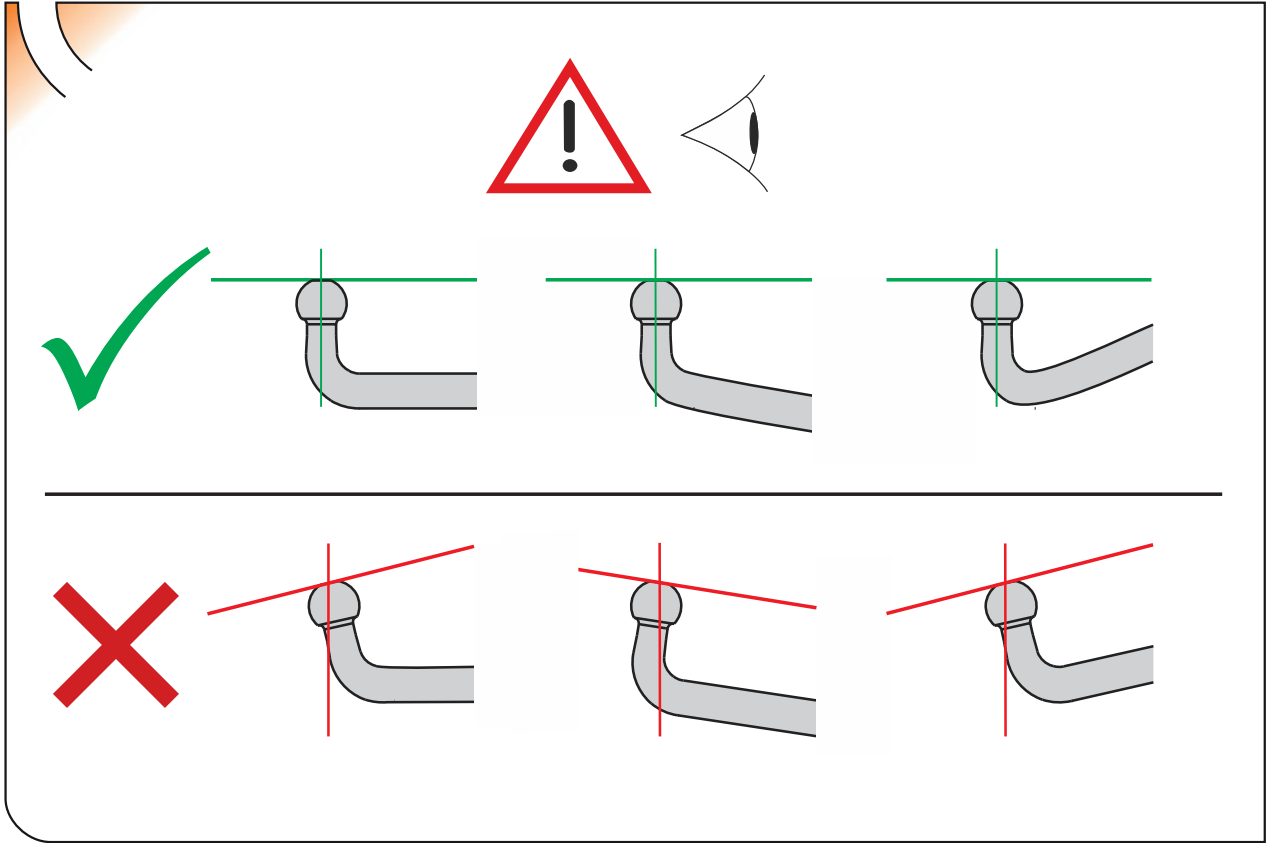

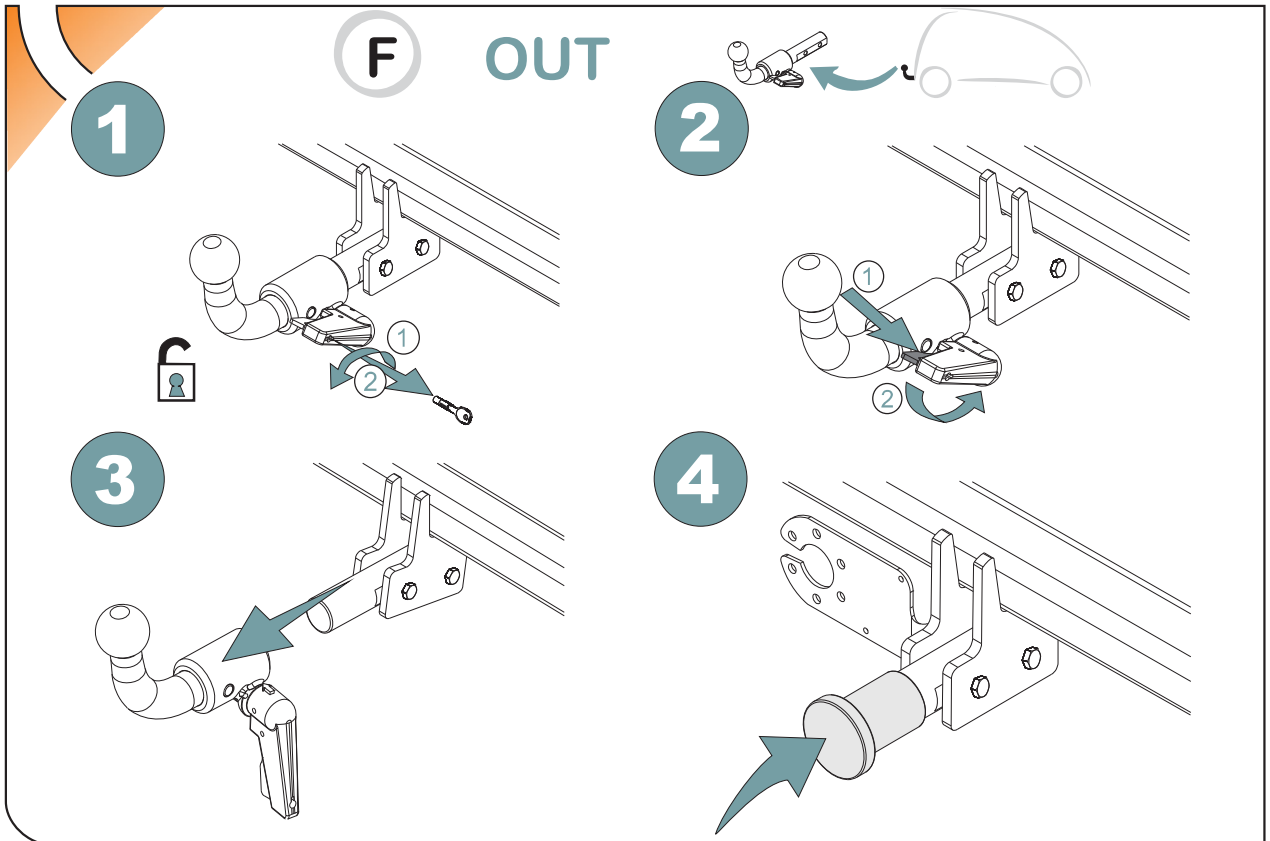
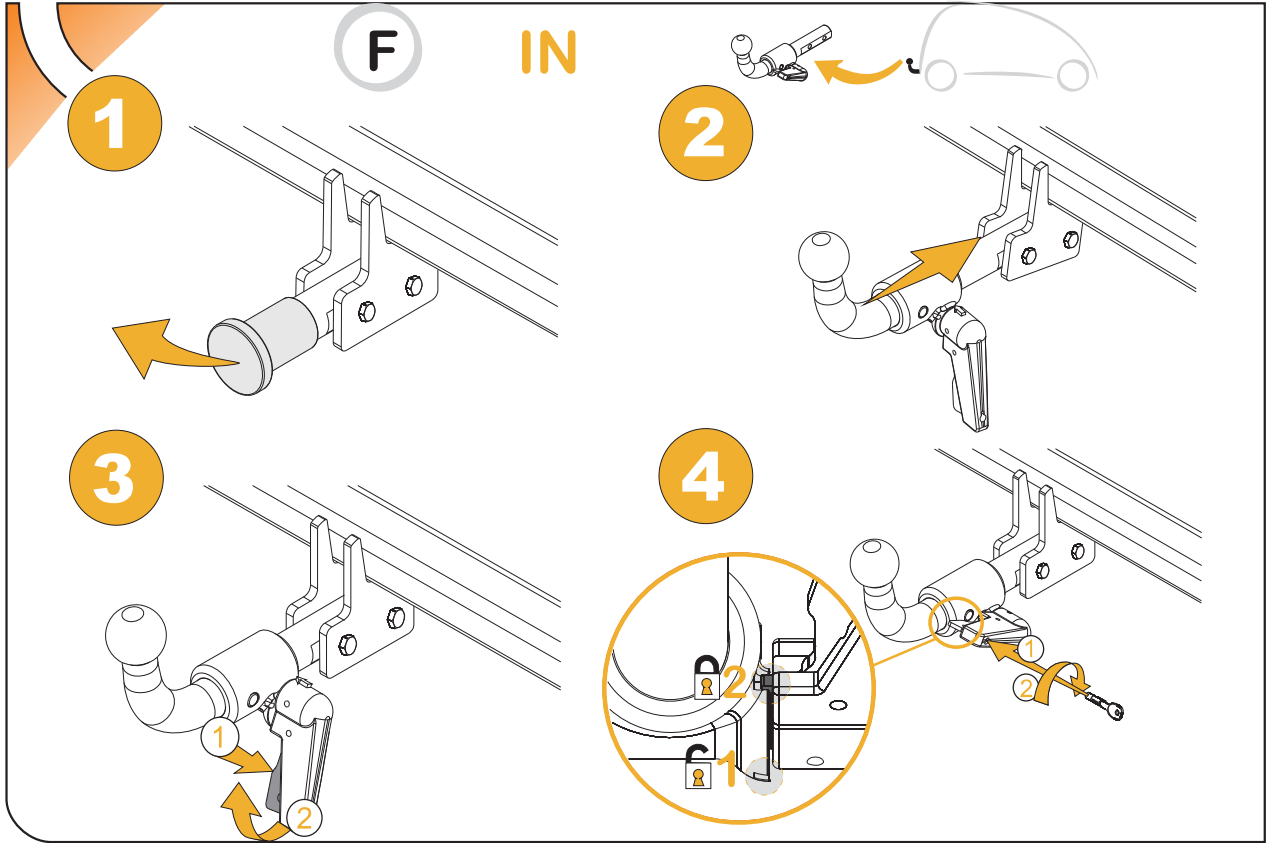

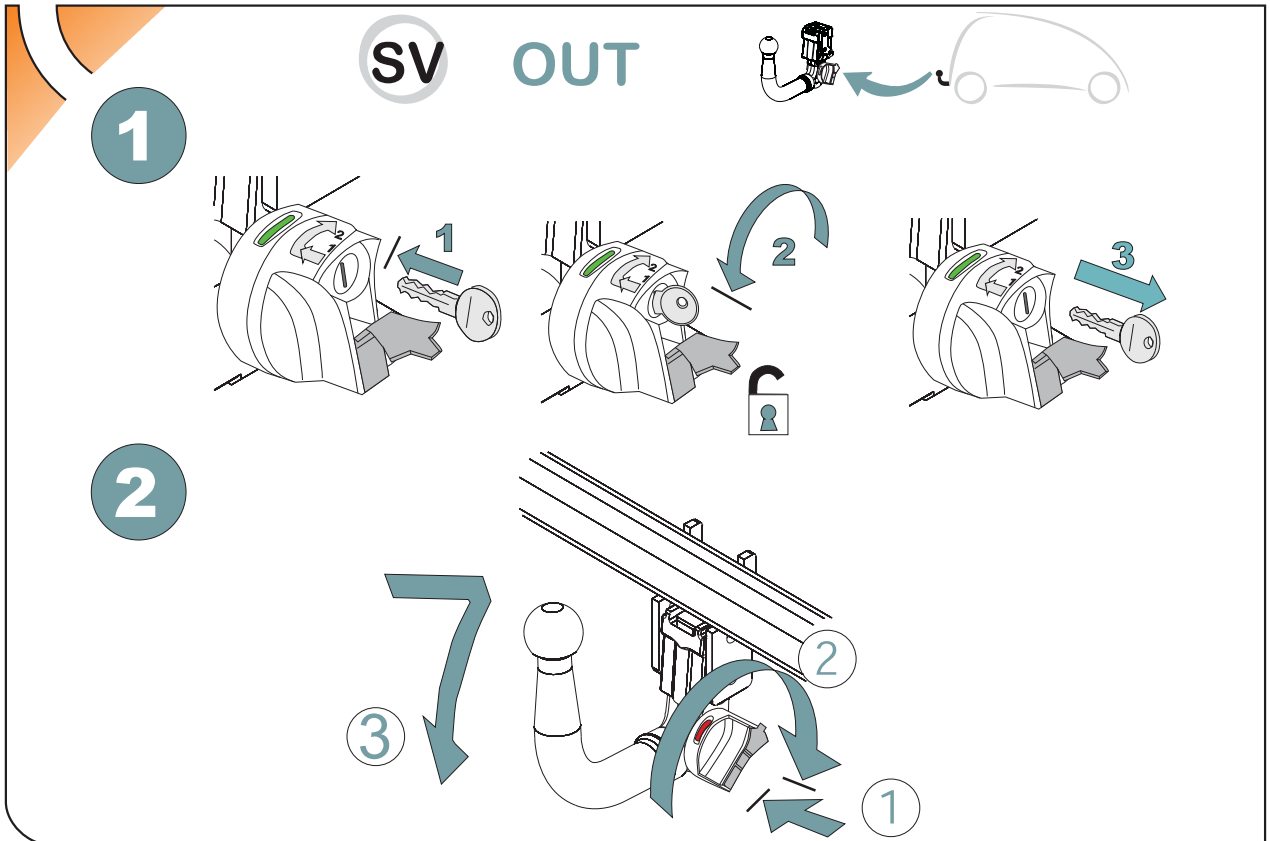
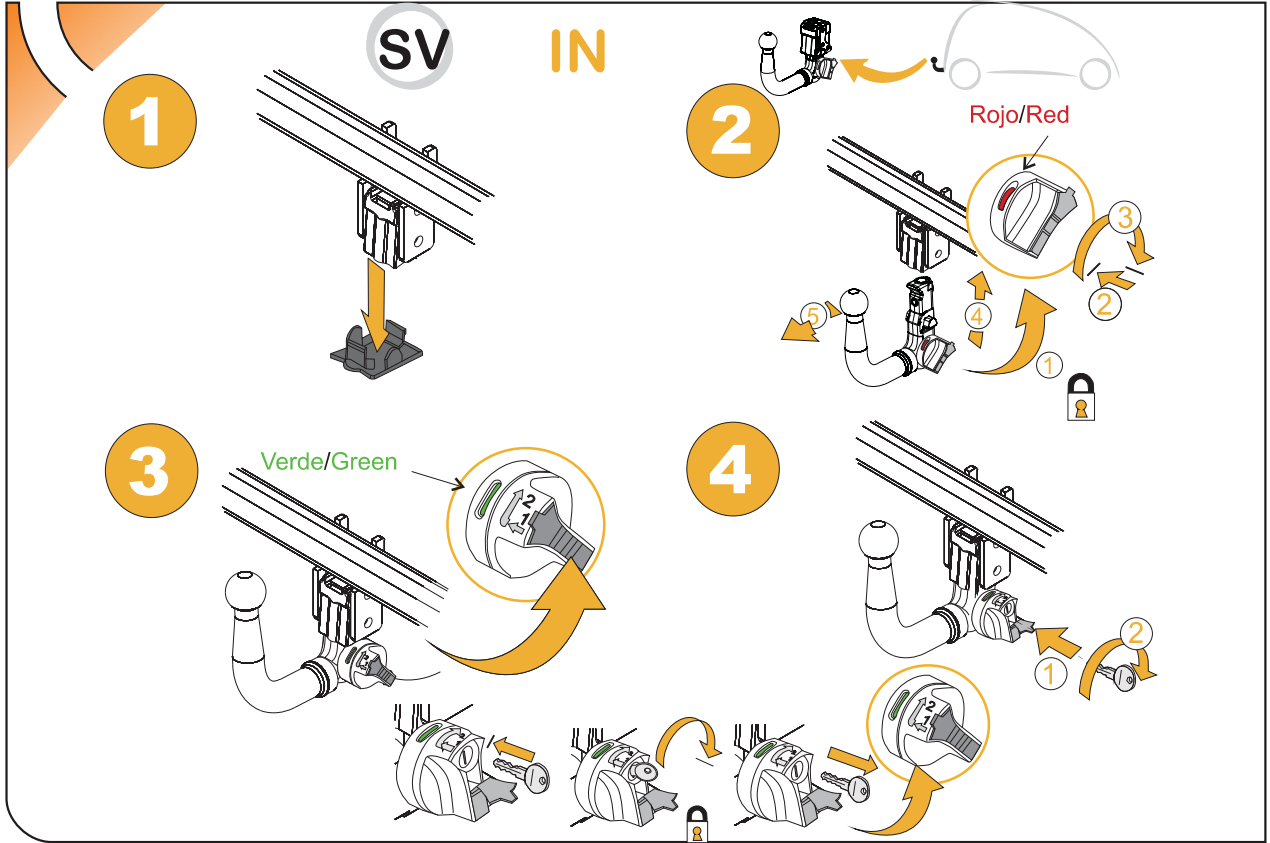



enganches
aragon

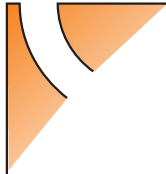

TowBox[®]



enganches
aragon

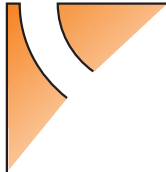

TowBox®

ANEXO III

CERTIFICADO DE TALLER

D. _____, expresamente autorizado por la empresa _____
domiciliada en _____, teléfono _____, dedicada
a la actividad de _____ n° de Registro Industrial _____ y n° de registro
especial (1) _____.

CERTIFICA

Que la mencionada empresa ha realizado la/s Reforma/s y asume la responsabilidad de la ejecución,
sobre el vehículo marca....., tipo.....
variante..... denominación comercial
matrícula y n° de bastidor, de acuerdo con:

- La normativa vigente en materia de reformas de vehículos.
- Las normas del fabricante del vehículo aplicables a la/s reforma/s llevadas a cabo en dicho vehículo.
- El proyecto descriptivo de la/s reforma/s, adjunto al expediente.

OBSERVACIONES: (2)

Tipificada/s con el código de reforma/s.....
Reforma consiste en:

COLOCACION DE ENGANCHE HOMOLOGADO EUROPEO MARCA:

n° de identificación / marca de homologación:

Type :

Garantizo que se cumple lo previsto en el artículo 6 del Reglamento General de vehículos y, en su caso, en el artículo 9 del R.D. 1457/1986, de 10 de enero, por el que se regula la actividad industrial en talleres de vehículos automóviles, de equipos y sus componentes, modificado por 455/2010 de 16 de abril.

....., a.....de.....de

Firma y sello:

(1) En el caso de que la reforma sea efectuada por el fabricante se indicará N/A.

(2) Se debe especificar en este apartado OBSERVACIONES, la identificación de los equipos o sistemas modificados.

ES

1



2



3



IT

1

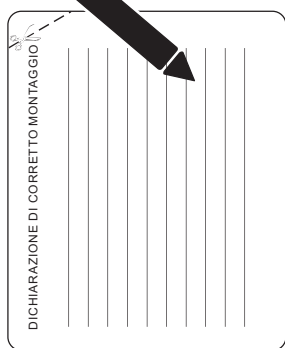

2

