

**SEAT Leon ST (2017- )**  
**Skoda Octavia Combi (2013-2016)**  
**Volkswagen Golf VIII (2019- )**  
**SEAT Leon (2019- )**  
**Cupra Leon ST (2021- )**

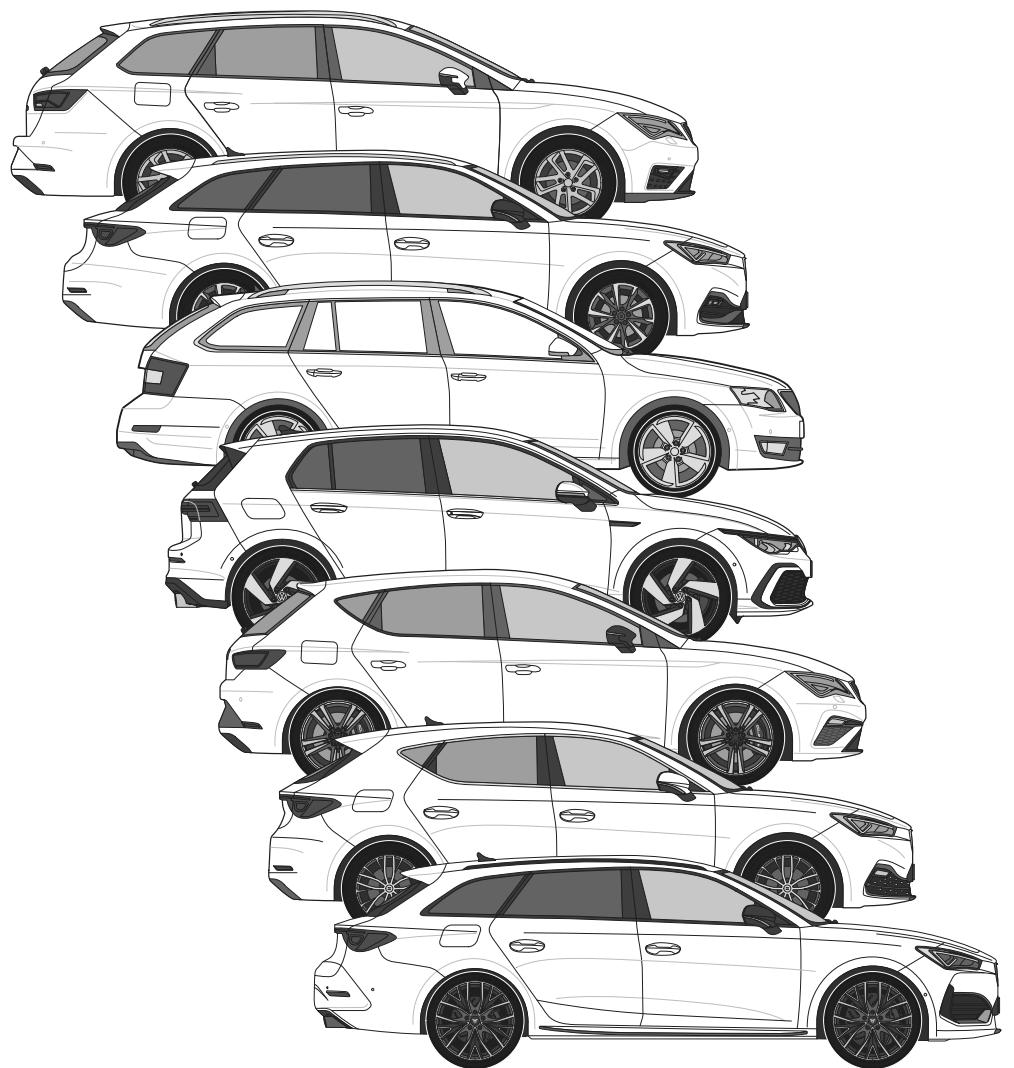



**R55**

SEAT Leon ST (2017-)  
 Skoda Octavia Combi (2013-2016)  
 Volkswagen Golf VIII (2019-)  
 SEAT Leon (2019-)  
 Cupra Leon ST (2021-)

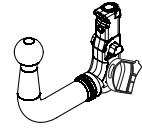
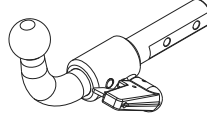
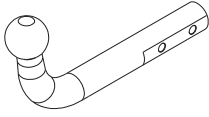

**TowCar** enganches **aragon**

**E13** APPROVALNUMBER **55R-01 4642** D-VALUE D **10,4** kN

TYPE **VWG051** CLASS **A50-X** MAX.VERT.LOAD S **127** kg

**TowCar** enganches **aragon**

**E13** APPROVALNUMBER **55R-01 4643** D-VALUE D **10,4** kN

TYPE **VWG052** CLASS **A50-X** MAX.VERT.LOAD S **127** kg

**TowCar** enganches **aragon**

**E13** APPROVALNUMBER **55R-01 4643** D-VALUE D **10,4** kN

TYPE **VWG052** CLASS **A50-X** MAX.VERT.LOAD S **127** kg

D = 10,4 kN



S = 127 kg

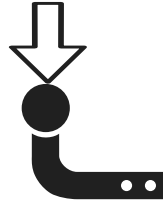

\*T 2000 Kg



N/m	8,8	10,9	12,9
<b>M6</b>	10	15	18
<b>M8</b>	24	36	42
<b>M10</b>	51	75	87
<b>M12</b>	87	130	147
<b>M14</b>	138	198	231
<b>M16</b>	200	289	341

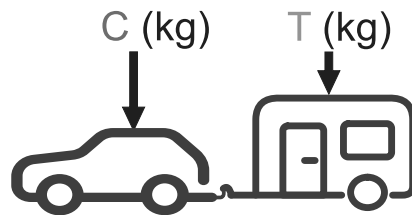



$g = 9,81 \text{ m/s}^2$

$$D \geq \frac{T \cdot C}{T + C} \cdot \frac{g}{1000} \text{ (kN)}$$

$$T \leq \frac{C \cdot D \cdot 1000}{(C \cdot g) - (1000 \cdot D)} \text{ (kg)}$$

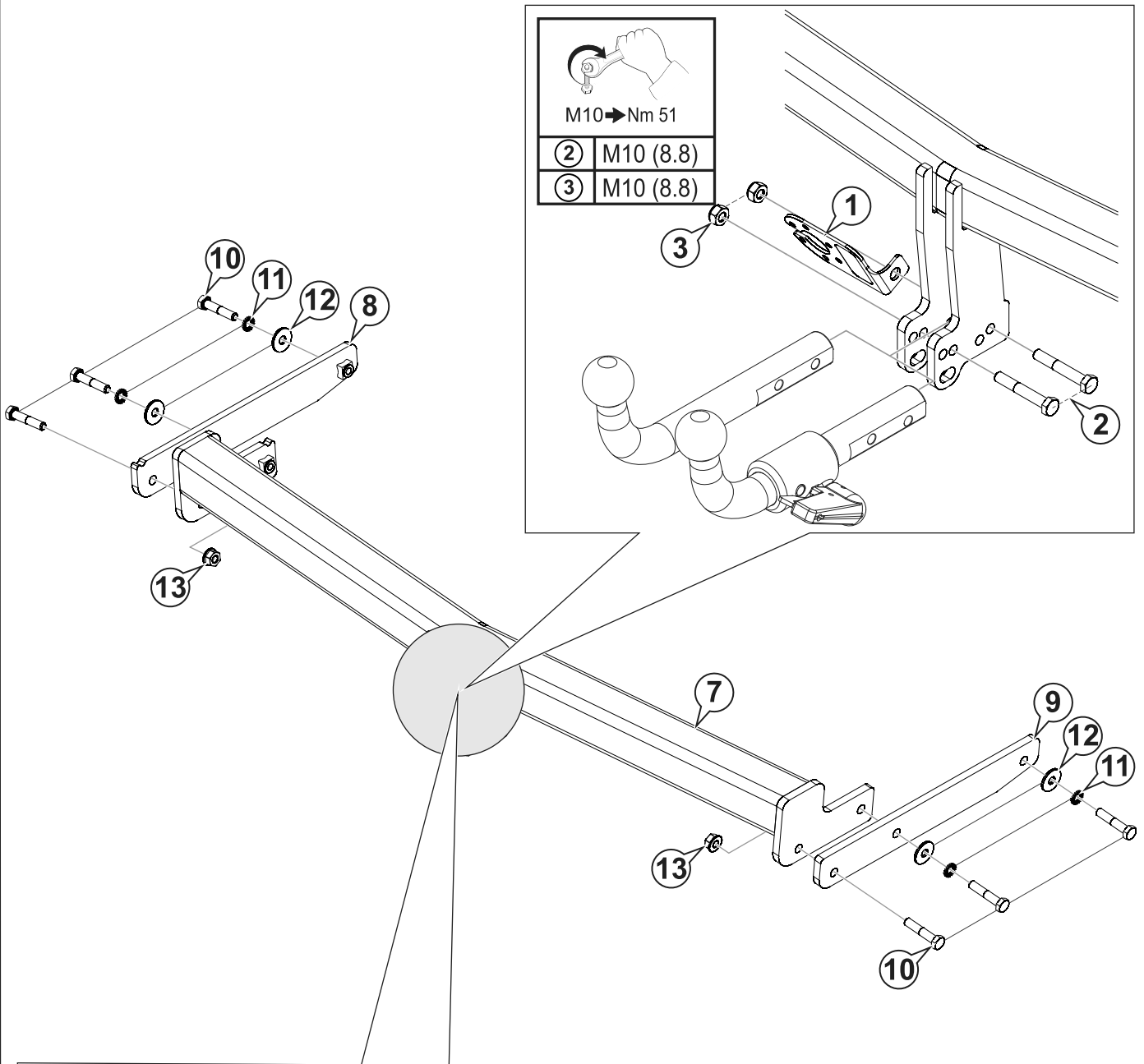
\*El MMR (T) puede variar dependiendo del vehículo.







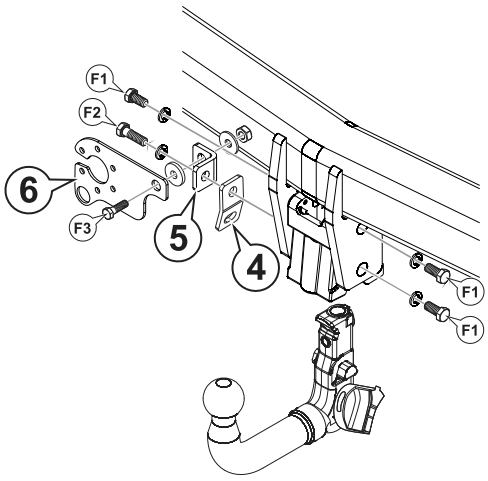



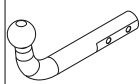

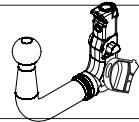

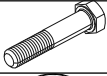
 M10 → Nm 51	
②	M10 (8.8)
③	M10 (8.8)

		#
<b>F1</b>	M12 x 25 DIN 933	3
	Ø12 Grower DIN 128	3
<b>F2</b>	M12 x 35 DIN 933	1
	Ø12 Grower DIN 128	1
<b>F3</b>	M10 x 30 DIN 933	1
	Ø10 Poliuretano / Nylon	1
	Ø10 DIN 9021	1
	M10 DIN 980	1

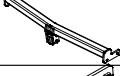
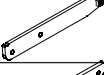
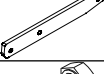
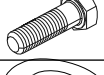

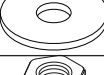
 M12 → N/m 87 M10 → N/m 51	
ⓕ1	M12 (8.8)
ⓕ2	M12 (8.8)
ⓕ3	M10 (8.8)

					
1		AEV0005	1		
2		M10x65 DIN 931 (8.8)	2		
3		M10 DIN 980	2		
4		AEV0006			1
5		AEV0008			1
6		AEV0009			1
7		C6701EX60	1		1
8		C6701EA41	1		1
9		C6701EA40	1		1
10		M10x50 DIN 933 (8.8)	6		6
11		Ø10 DIN 128A	4		4
12		Ø10 DIN 9021	4		4
13		M10 DIN 6923	2		2

1

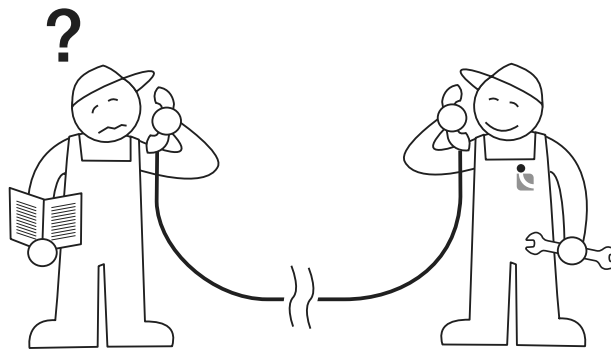

Tel.: (+34) 976 457 130

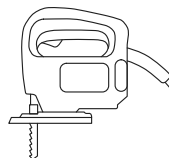
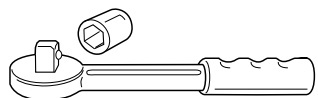
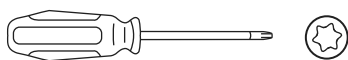

2

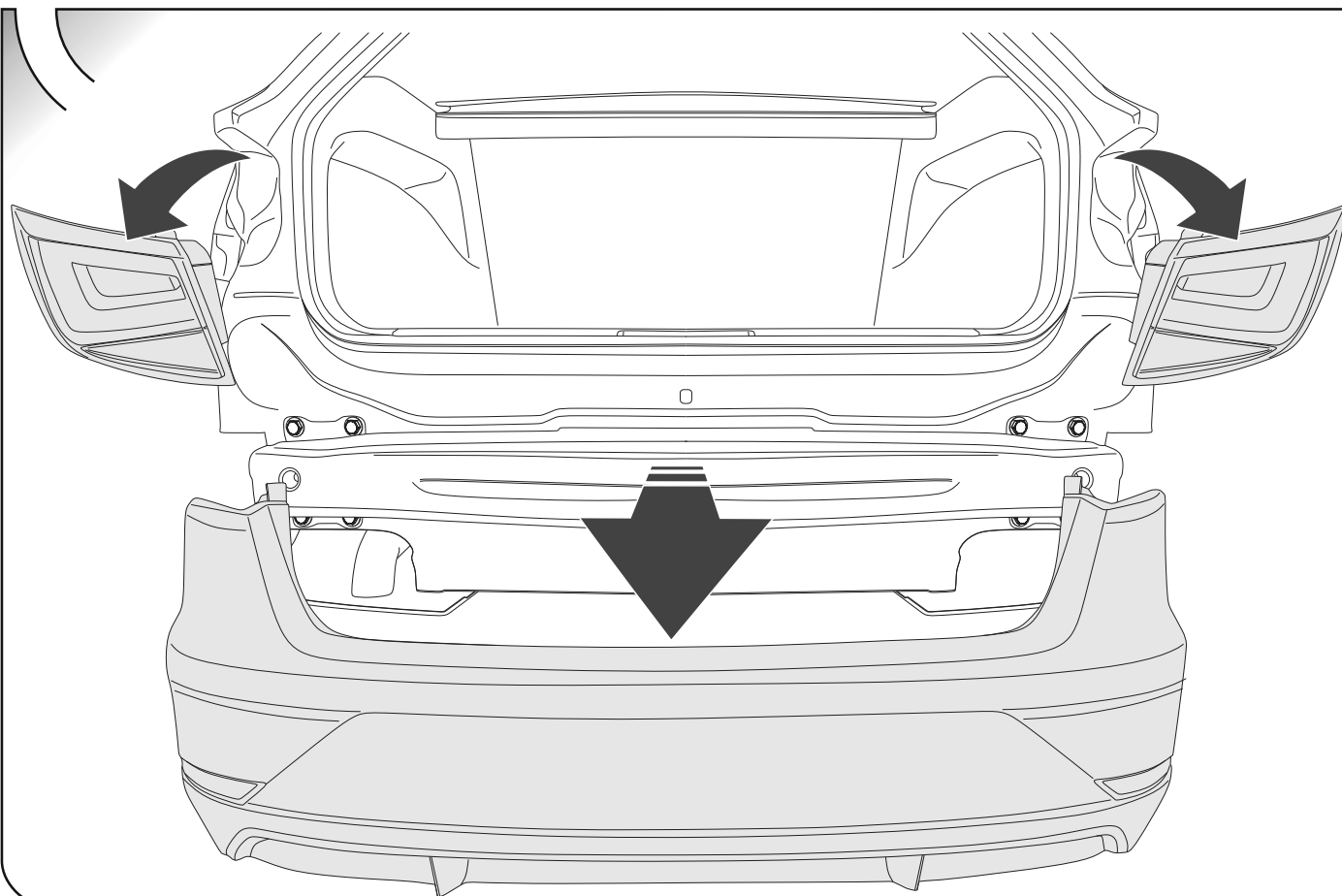

3

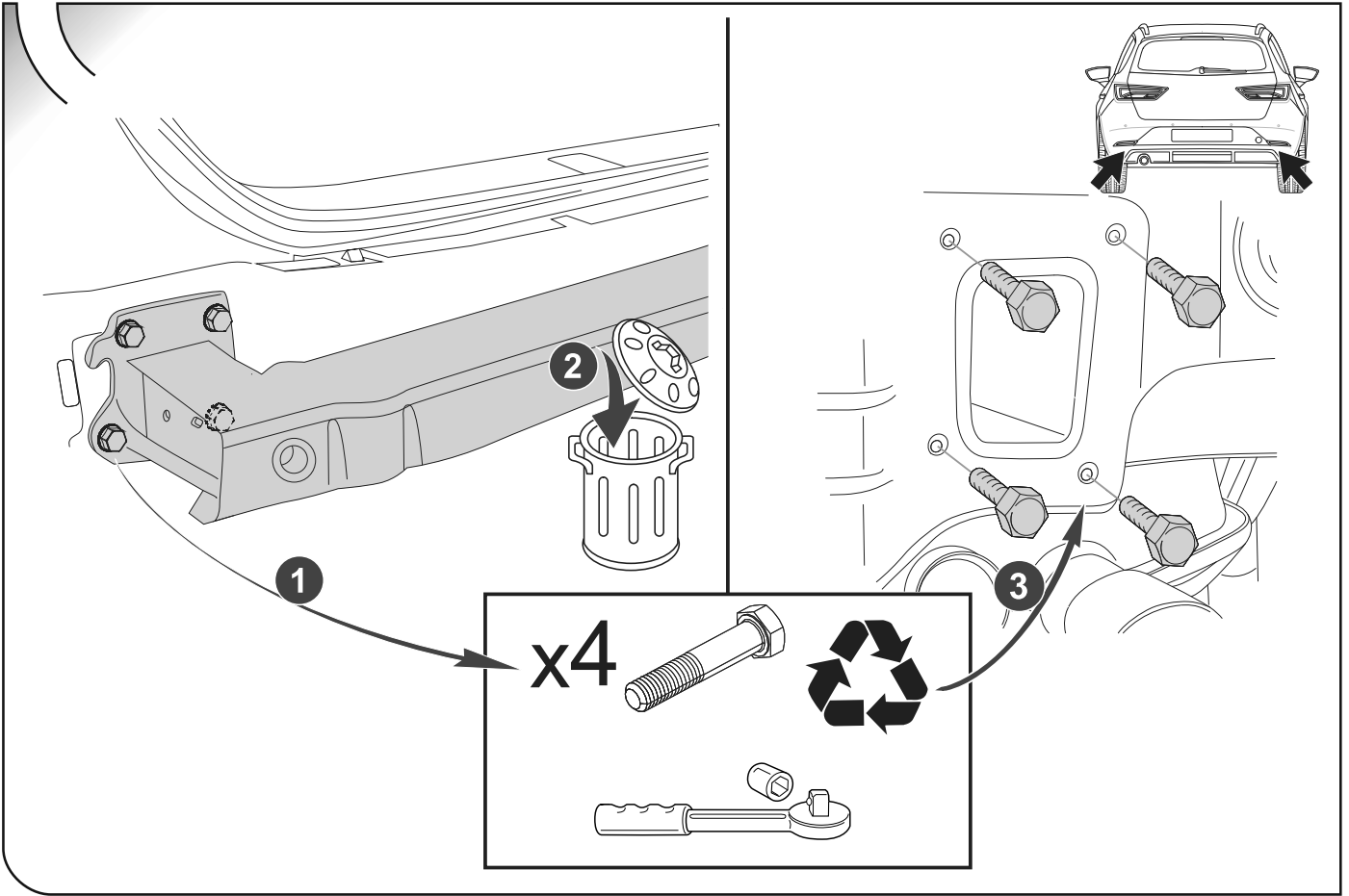

4

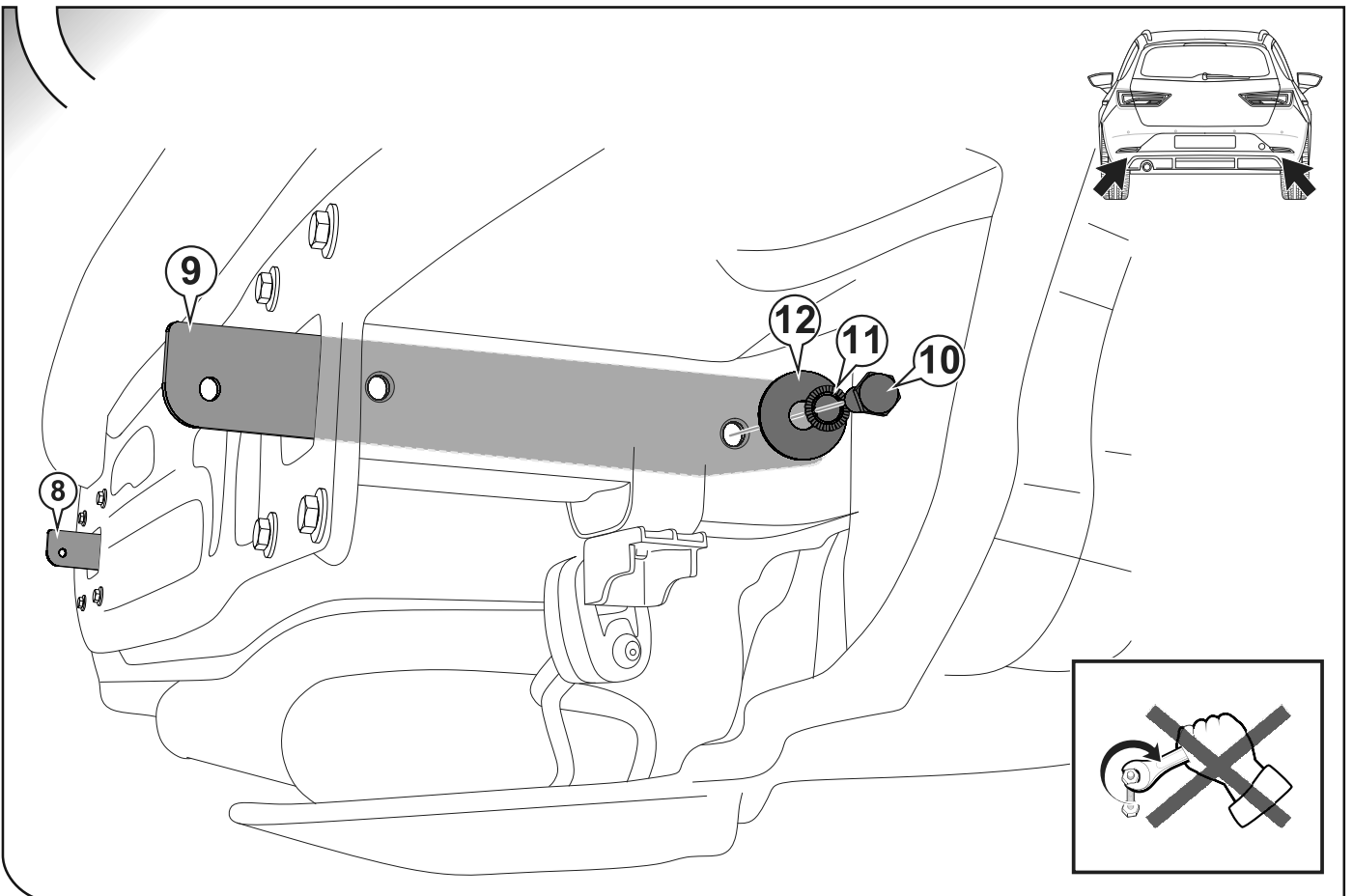

5

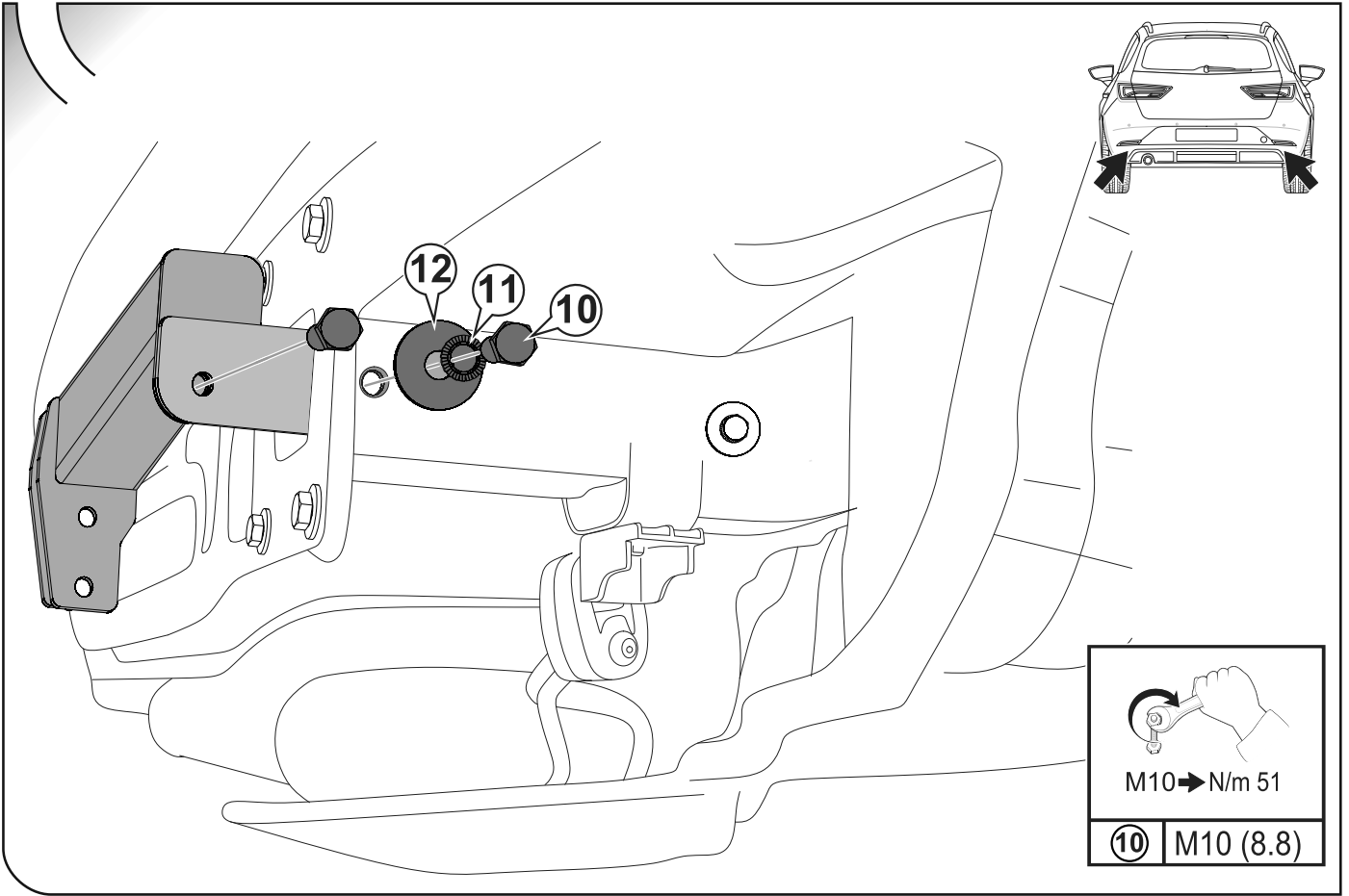

6

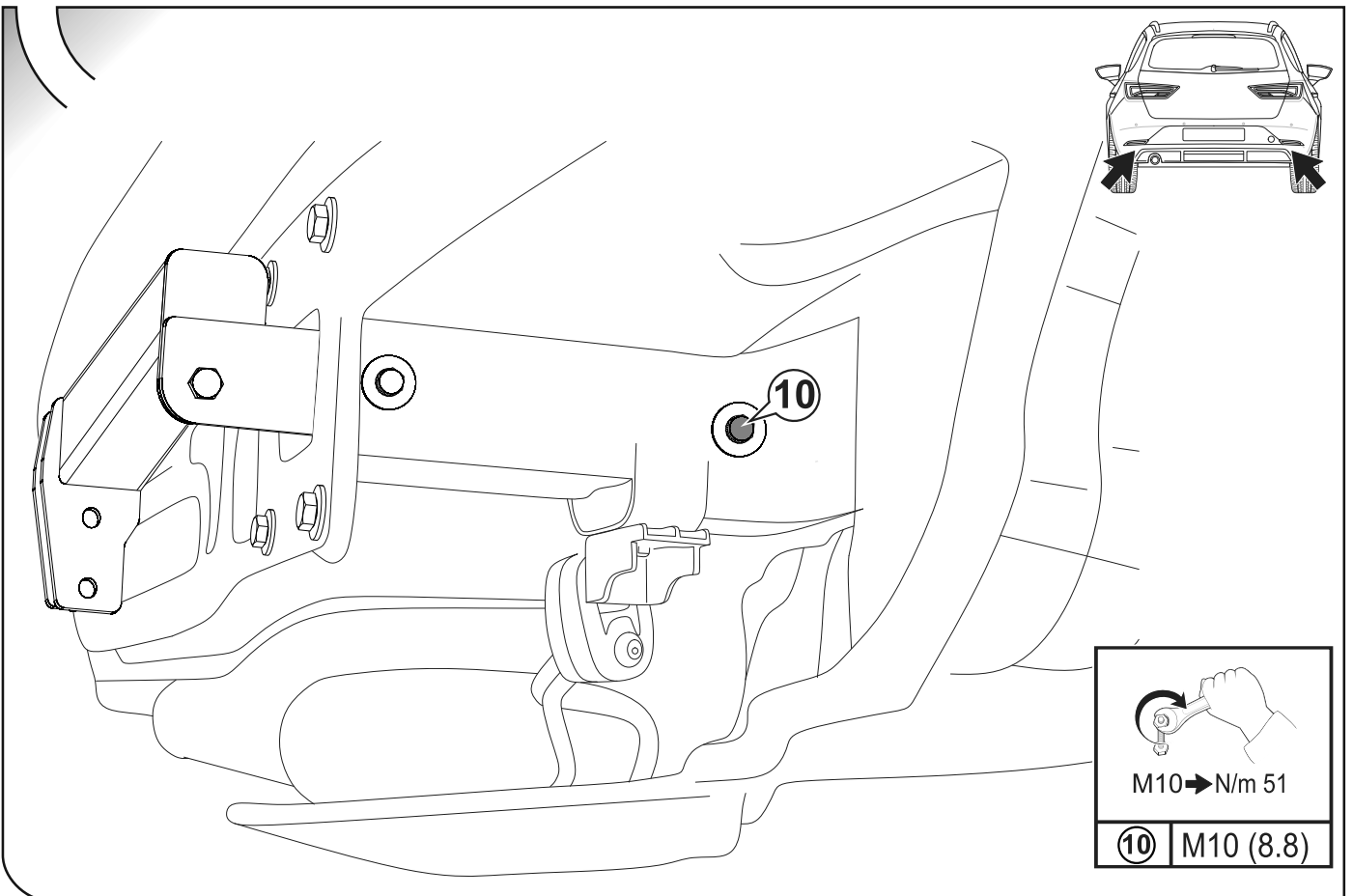



7

Volkswagen Golf VIII

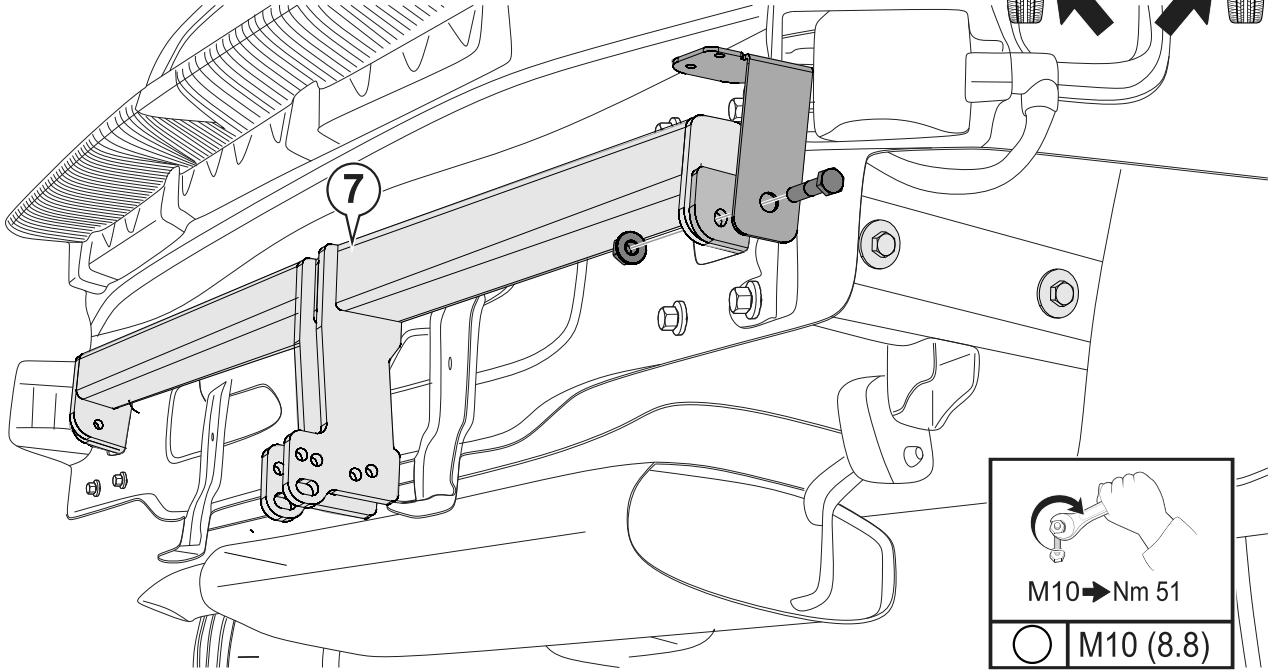

8

Volkswagen Golf VIII

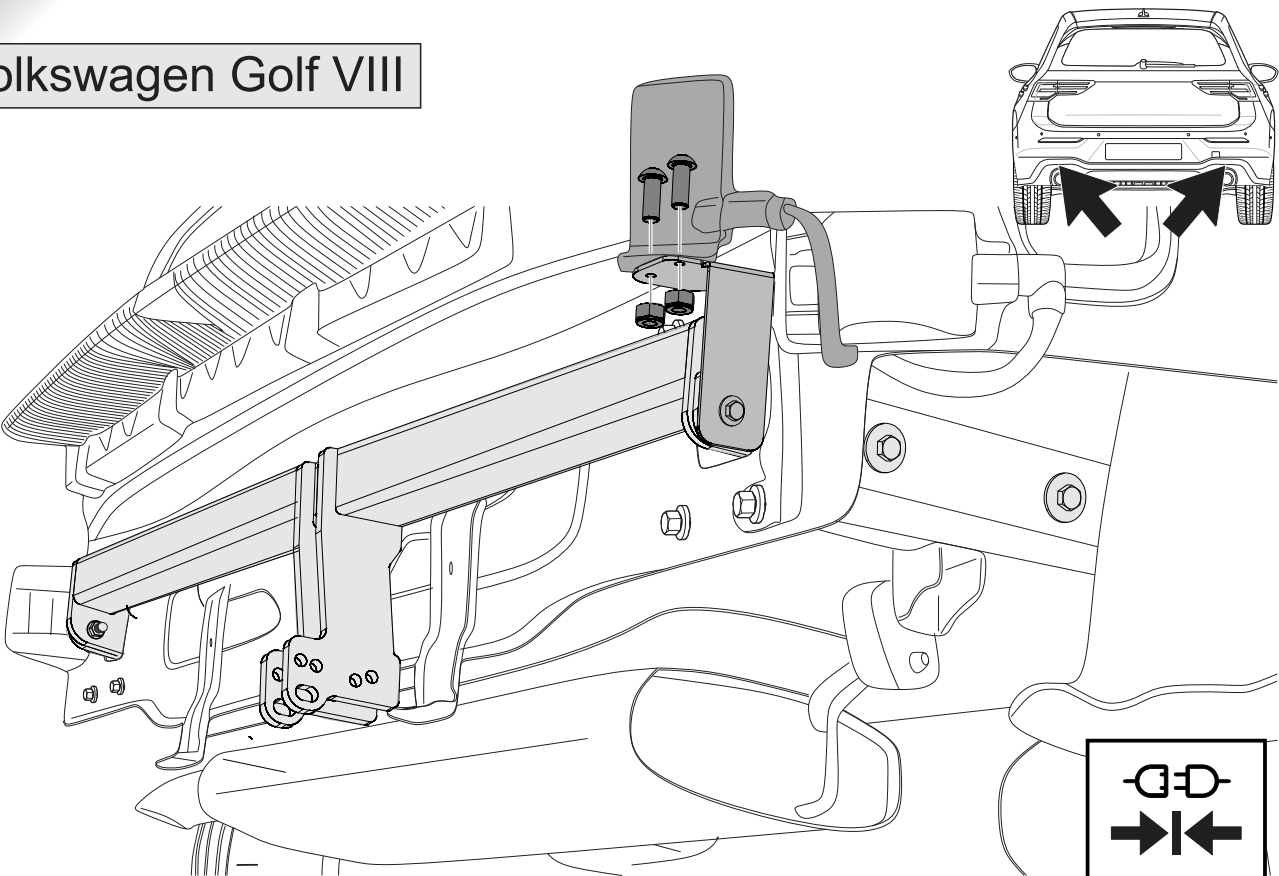

9

SEAT Leon (2017-2019)

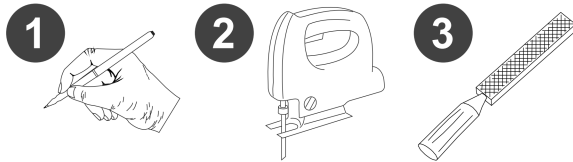
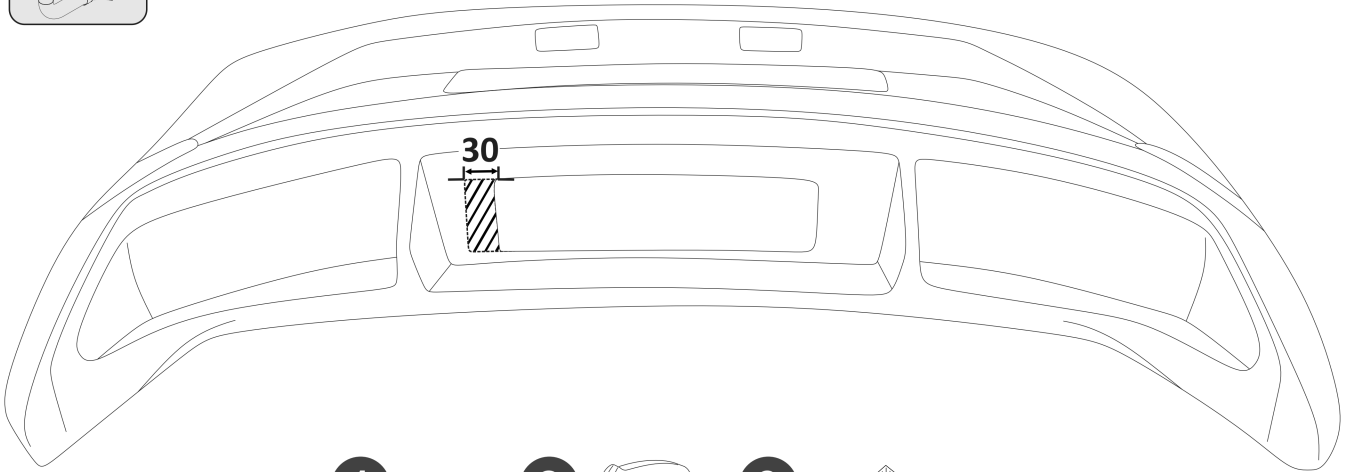
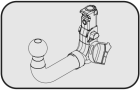

10

Skoda Octavia Combi

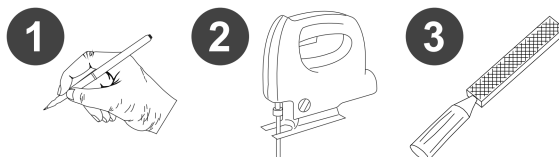
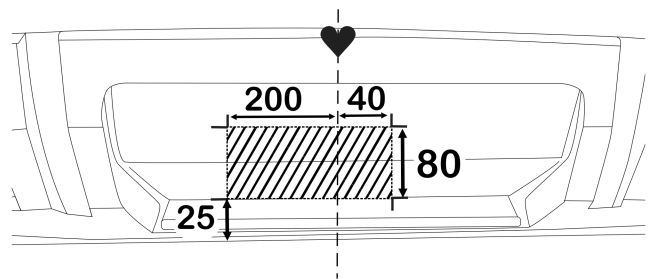
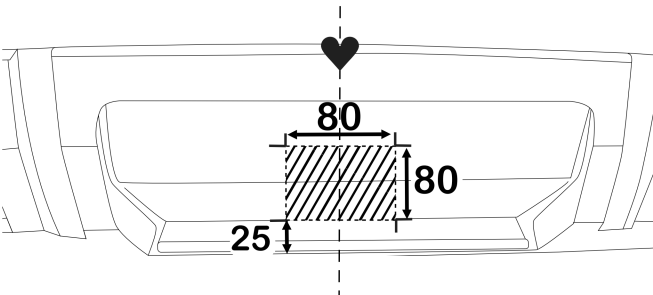
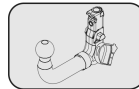
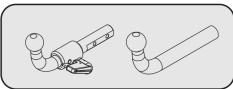

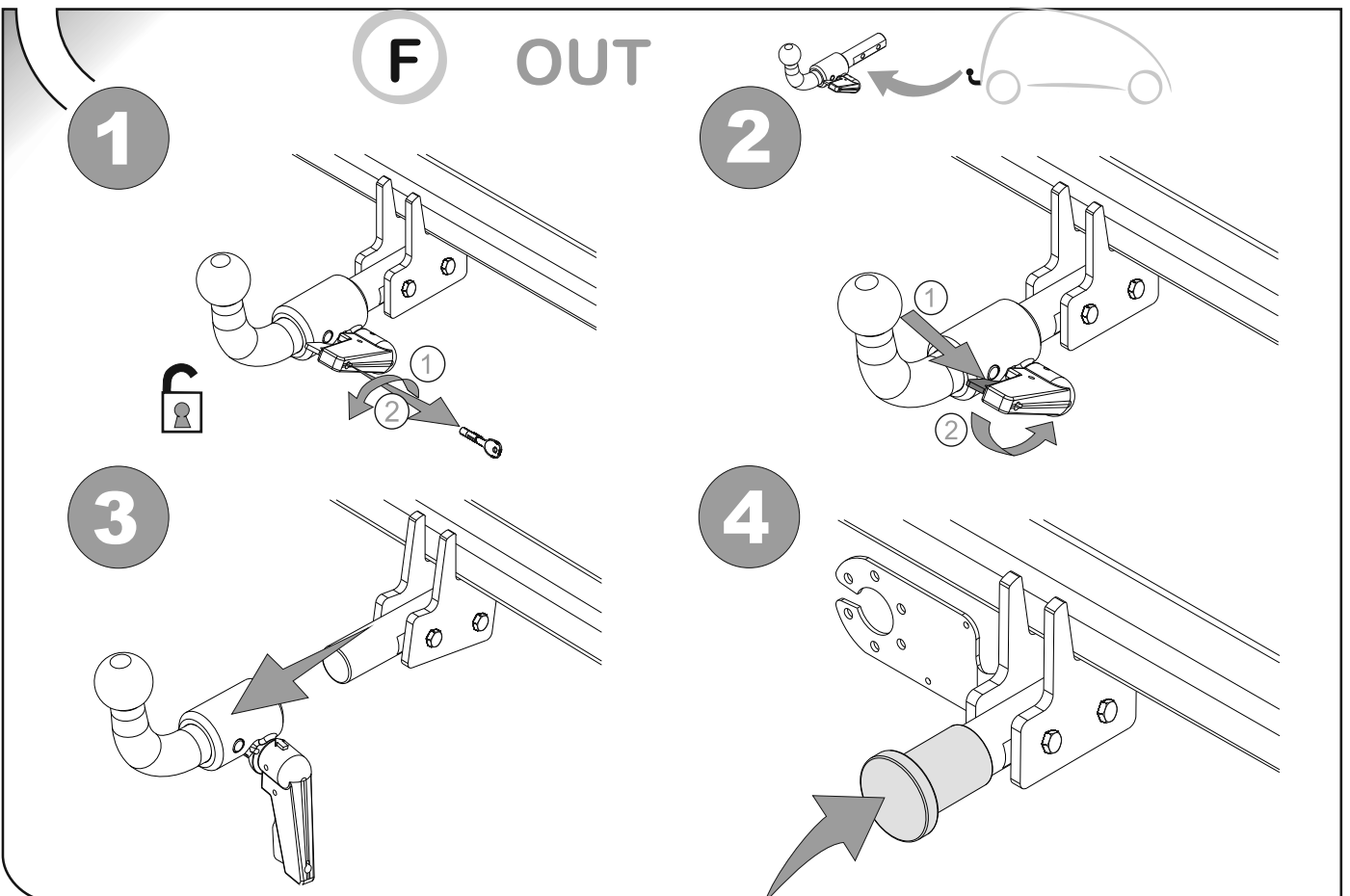
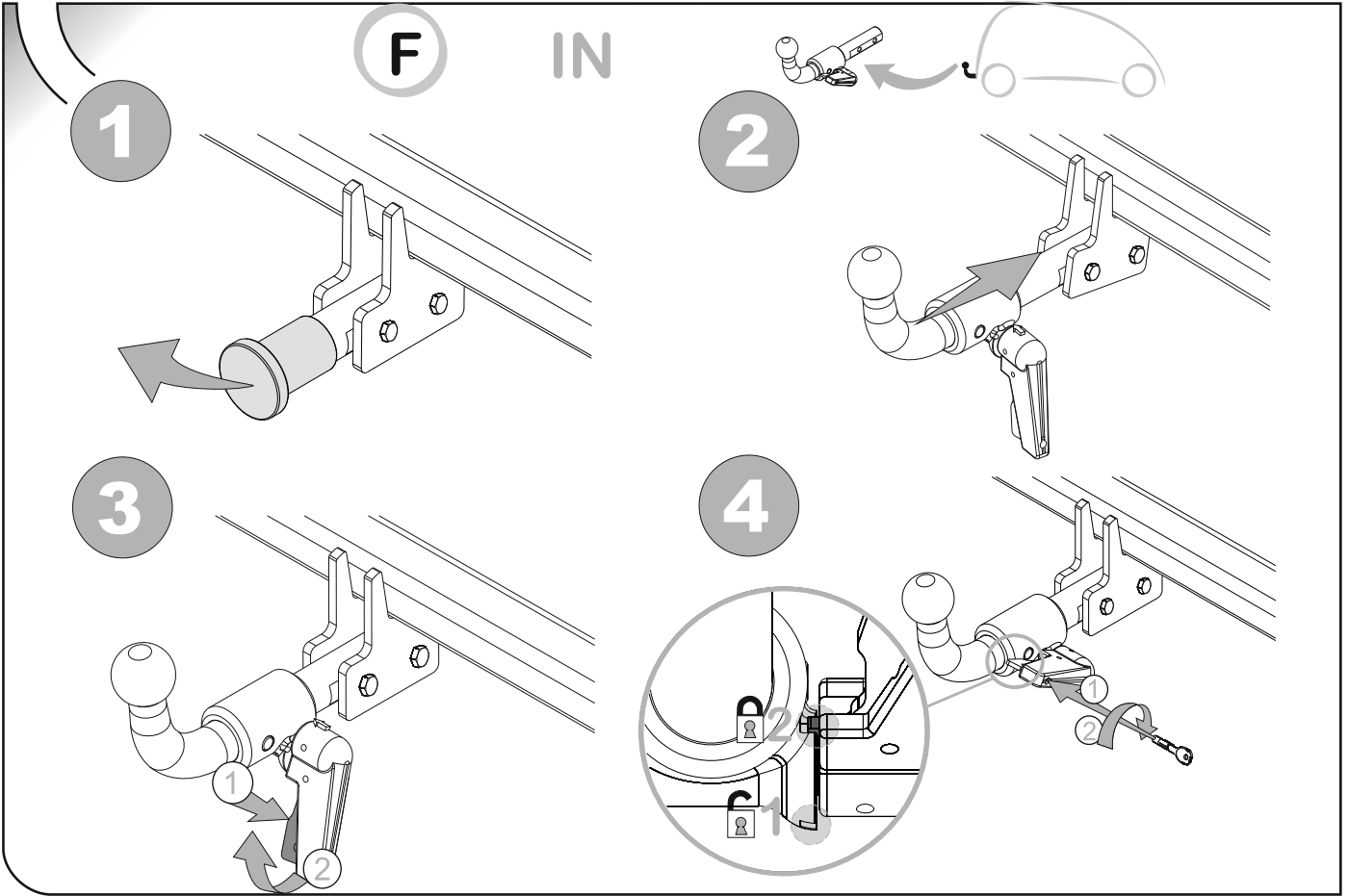

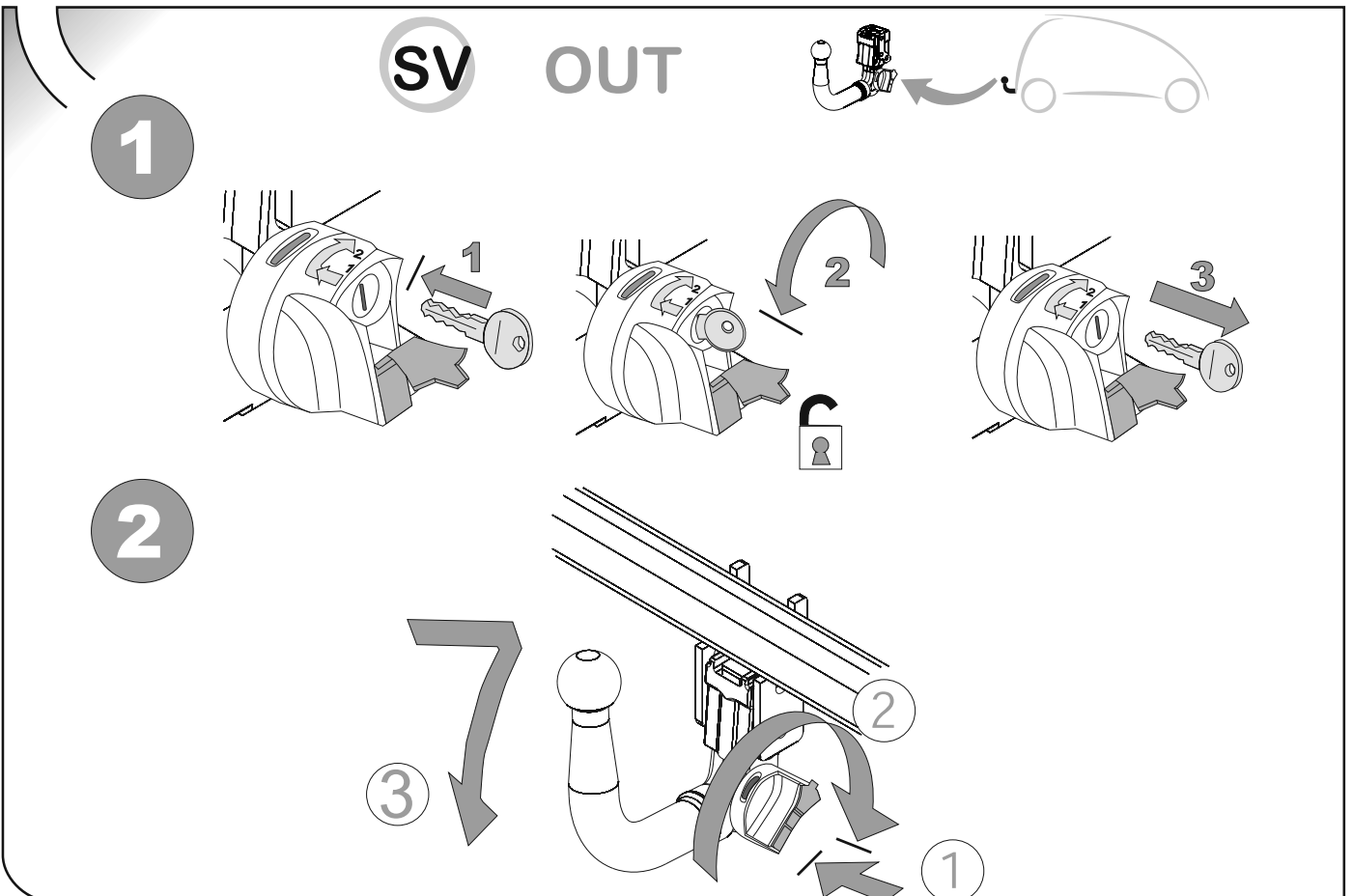
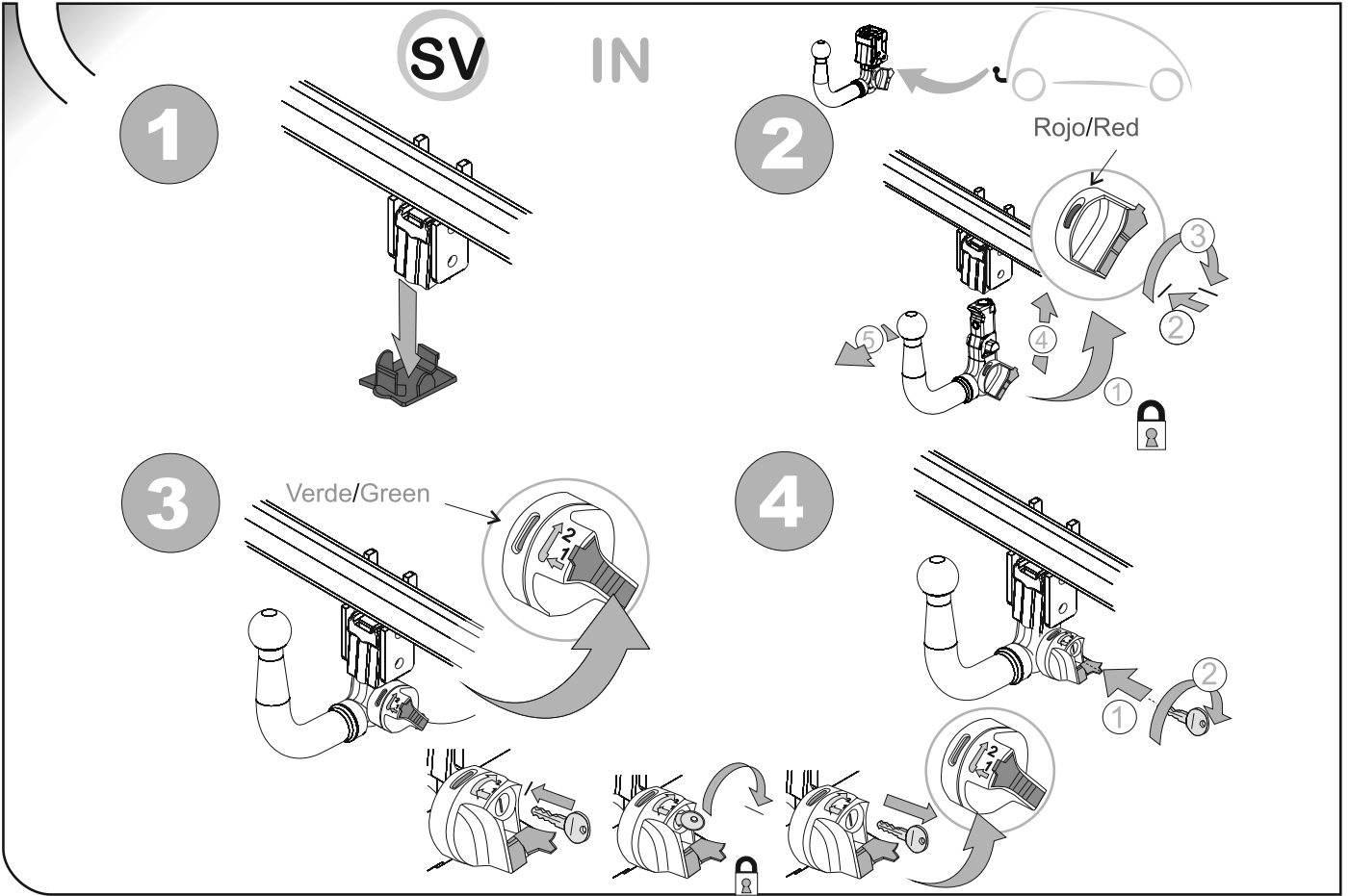

# ANEXO III

## CERTIFICADO DE TALLER

D. \_\_\_\_\_, expresamente autorizado por la empresa \_\_\_\_\_  
domiciliada en \_\_\_\_\_, teléfono \_\_\_\_\_, dedicada  
a la actividad de \_\_\_\_\_ n° de Registro Industrial \_\_\_\_\_ y n° de registro  
especial (1)\_\_\_\_\_.

### CERTIFICA

Que la mencionada empresa ha realizado la/s Reforma/s y asume la responsabilidad de la ejecución,  
sobre el vehículo marca....., tipo.....  
variante..... denominación comercial .....  
matrícula ..... y n° de bastidor ....., de acuerdo con:

- La normativa vigente en materia de reformas de vehículos.
- Las normas del fabricante del vehículo aplicables a la/s reforma/s llevadas a cabo en dicho vehículo.
- El proyecto descriptivo de la/s reforma/s, adjunto al expediente.

### OBSERVACIONES: (2)

Tipificada/s con el código de reforma/s.....  
Reforma consiste en:

### COLOCACION DE ENGANCHE HOMOLOGADO EUROPEO MARCA:

\_\_\_\_\_

n° de identificación / marca de homologación:

Type :

Garantizo que se cumple lo previsto en el artículo 6 del Reglamento General de vehículos y, en su caso, en el artículo 9 del R.D. 1457/1986, de 10 de enero, por el que se regula la actividad industrial en talleres de vehículos automóviles, de equipos y sus componentes, modificado por 455/2010 de 16 de abril.

....., a.....de.....de .....

Firma y sello:

(1) En el caso de que la reforma sea efectuada por el fabricante se indicará N/A.

(2) Se debe especificar en este apartado OBSERVACIONES, la identificación de los equipos o sistemas modificados.

**ES**

1

ANEXO III  
CERTIFICADO DE TALLER



2

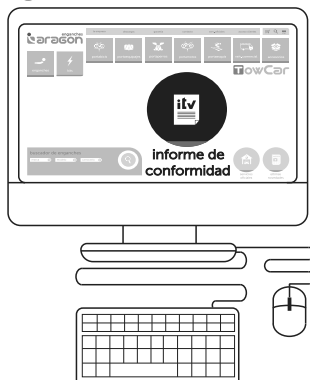

3



**IT**

1

DICHIARAZIONE DI CORRETTO MONTAGGIO

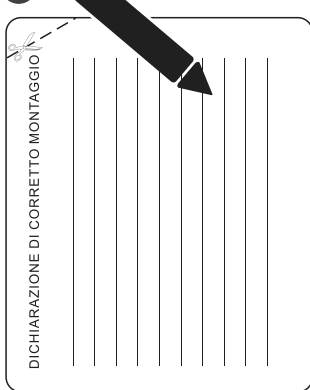

2

