

Hyundai Tucson (2020-)
Kia Sportage (2022-)

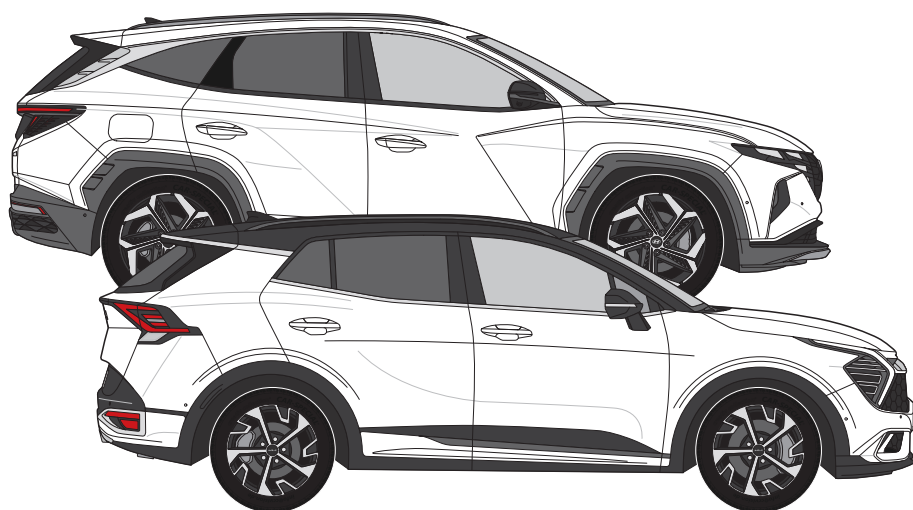

R55

Hyundai Tucson (2020-)
Kia Sportage (2022-)

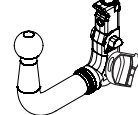
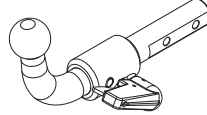
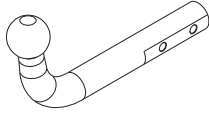

TowCar enganches **aragon**

E₉ APPROVALNUMBER: 55R-01-2600 D-VALUE: 11,5 kN
 TYPE: KIA051 CLASS: A50-X MAX.VERT.LOAD: 140 kg

TowCar enganches **aragon**

E₉ APPROVALNUMBER: 55R-01-2600 D-VALUE: 11,5 kN
 TYPE: KIA051 CLASS: A50-X MAX.VERT.LOAD: 140 kg

TowCar enganches **aragon**

E₉ APPROVALNUMBER: 55R-01-2601 D-VALUE: 11,5 kN
 TYPE: KIA052 CLASS: A50-X MAX.VERT.LOAD: 140 kg

D = 11,5 kN



S = 140 kg

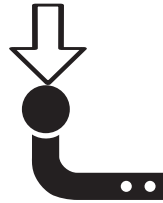

*T 2320 Kg



N/m	8,8	10,9	12,9
M6	10	15	18
M8	24	36	42
M10	51	75	87
M12	87	130	147
M14	138	198	231
M16	200	289	341

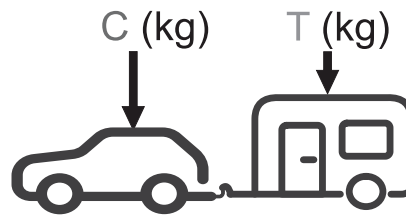

$g = 9,81 \text{ m/s}^2$

$$D \geq \frac{T \cdot C}{T + C} \cdot \frac{g}{1000} \text{ (kN)}$$

$$T \leq \frac{C \cdot D \cdot 1000}{(C \cdot g) - (1000 \cdot D)} \text{ (kg)}$$

*El MMR (T) puede variar dependiendo del vehículo.

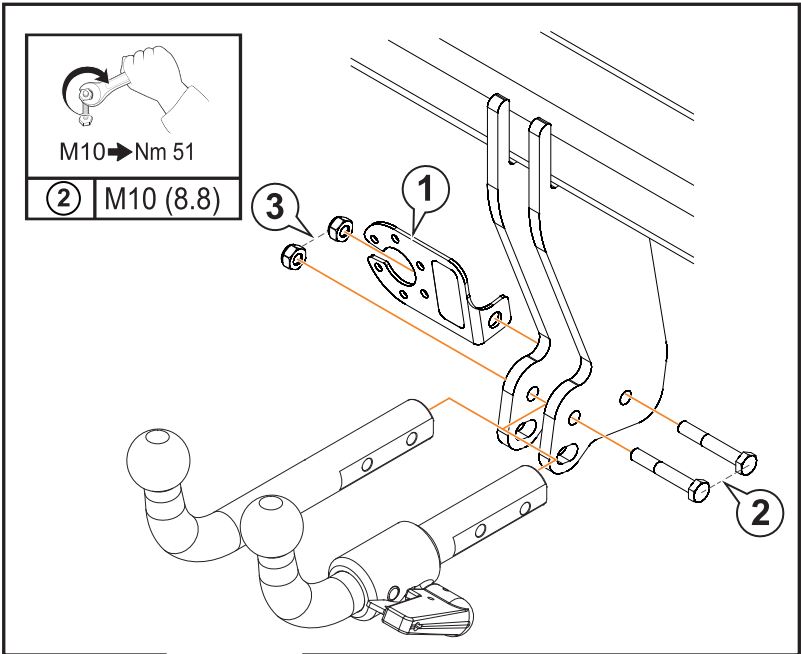
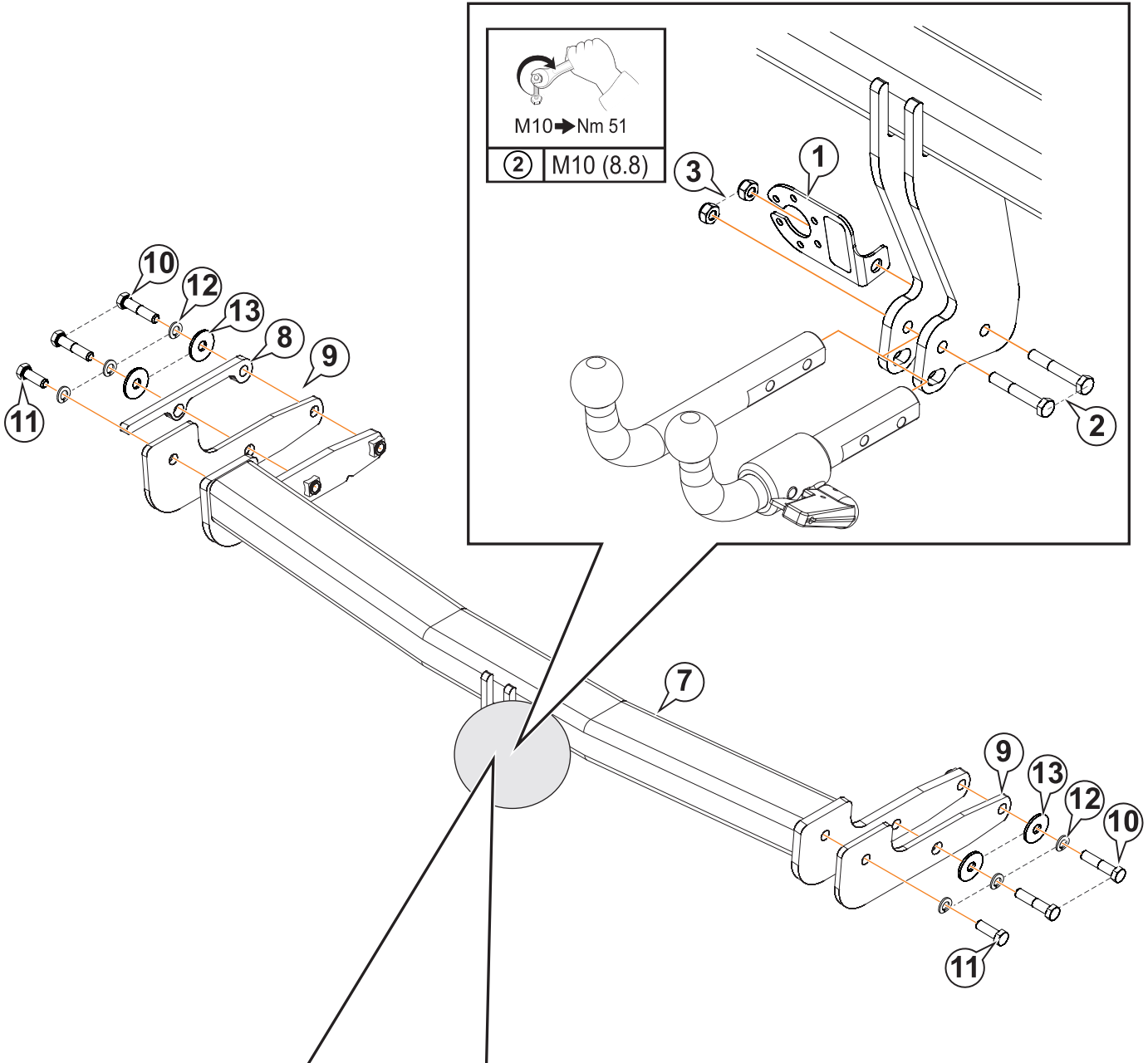

M10 → Nm 51



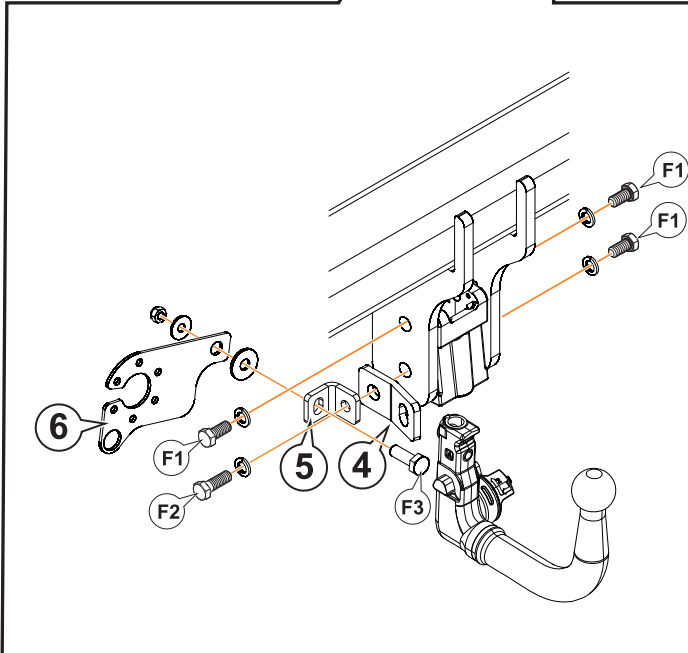





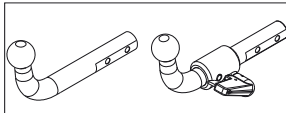
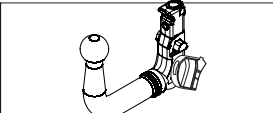

②	M10 (8.8)
---	-----------

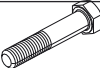

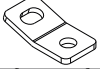
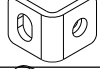
		#
F1	M12 x 25 DIN 933	3
	Ø12 Grower DIN 128	3
F2	M12 x 35 DIN 933	1
	Ø12 Grower DIN 128	1
F3	M10 x 30 DIN 933	1
	Ø10 Poliuretano / Nylon	1
	Ø10 DIN 9021	1
	M10 DIN 980	1

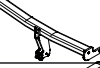
M12 → Nm 87
M10 → Nm 51

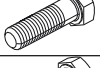
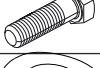
ⓕ1	M12 (8.8)
ⓕ2	M12 (8.8)
ⓕ3	M10 (8.8)

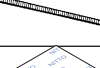
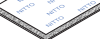
				
1		AEV0005	1	
2		M10x65 DIN 931 (8.8)	2	
3		M10 DIN 980	2	
4		AEV0006		1
5		AEV0008		1
6		AEV0009		1
7		C2502HX60	1	1
8		C2502HV28	1	1
9		C2502HV27	2	2
10		M12x60 DIN 933 (8.8)	4	4
11		M12x35 DIN 933 (8.8)	2	2
12		Ø12 DIN 128A	6	6
13		Ø12 DIN 9021	4	4
14		360 x 4,8	2	2
15		ALV0C03	1	1

1



5 min.

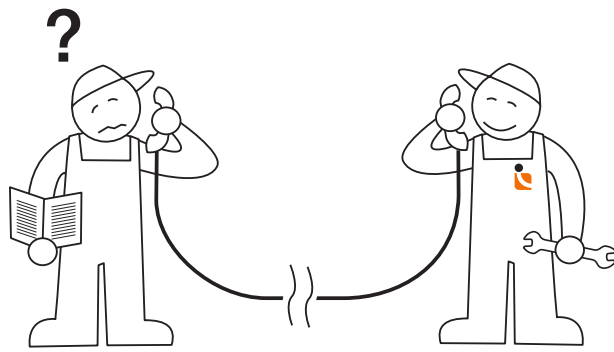

Tel.: (+34) 976 457 130

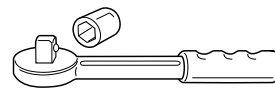

2

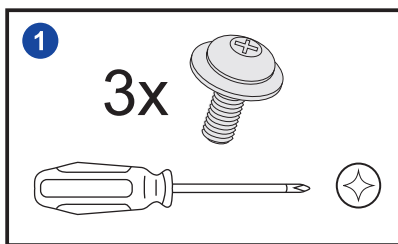

3x

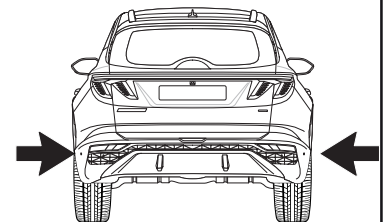
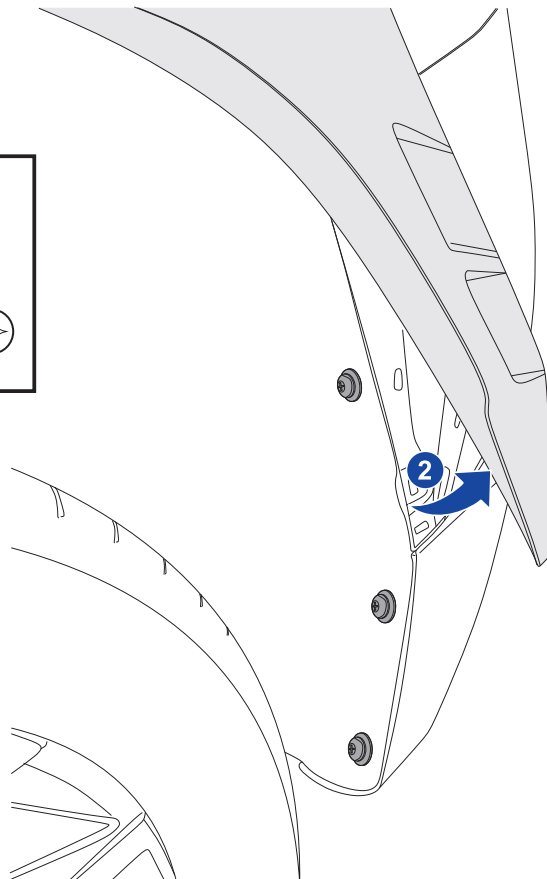

3

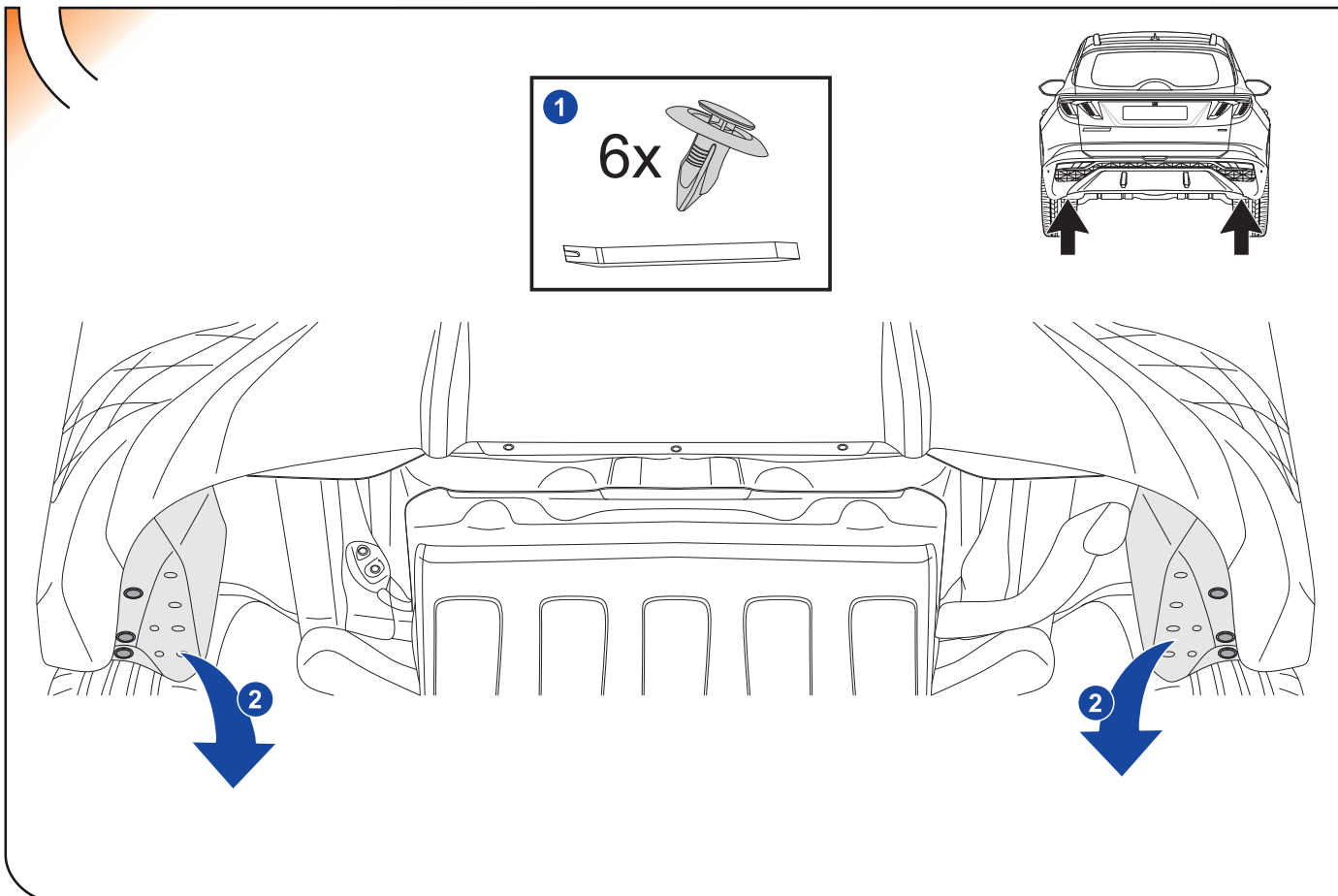

4

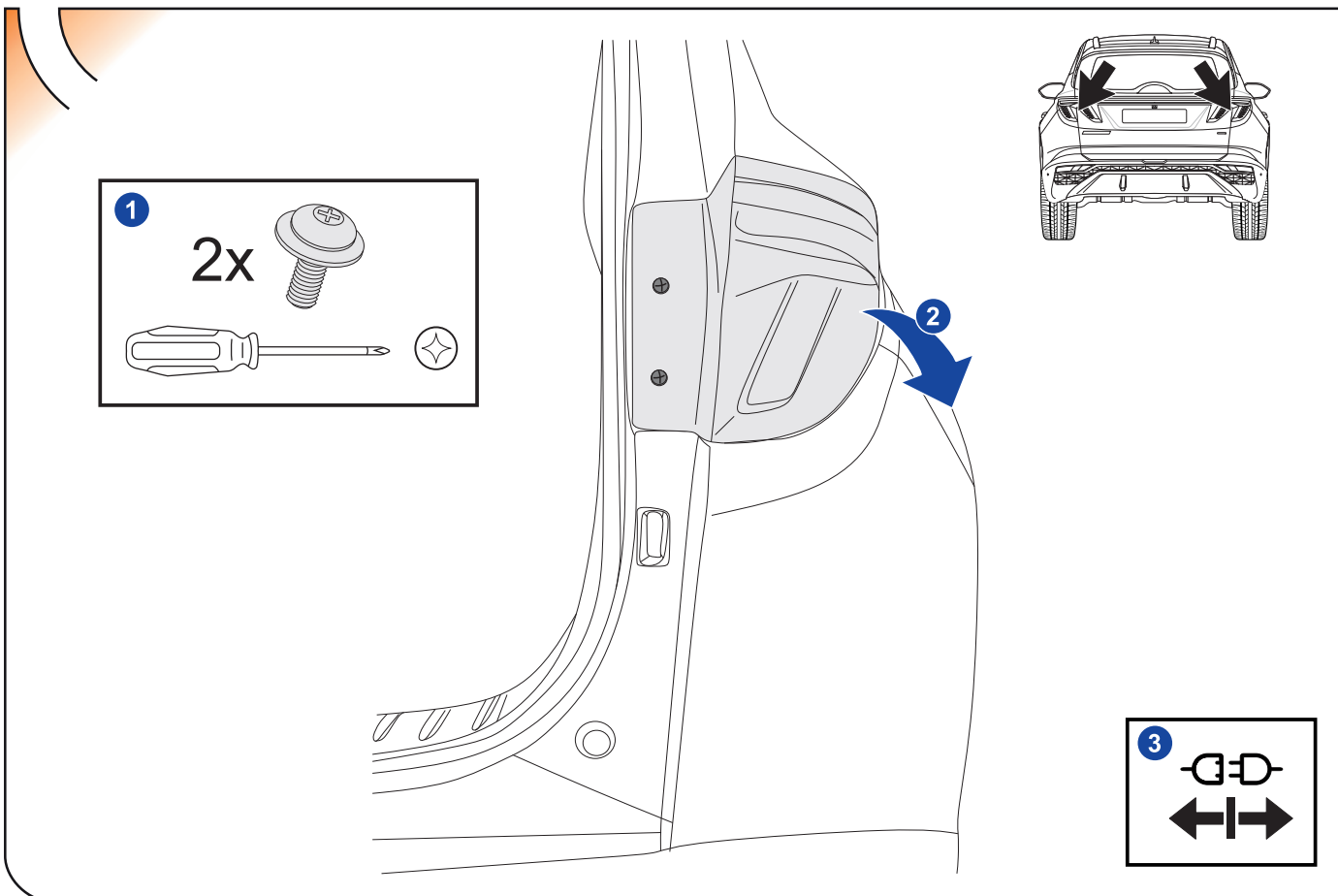

5

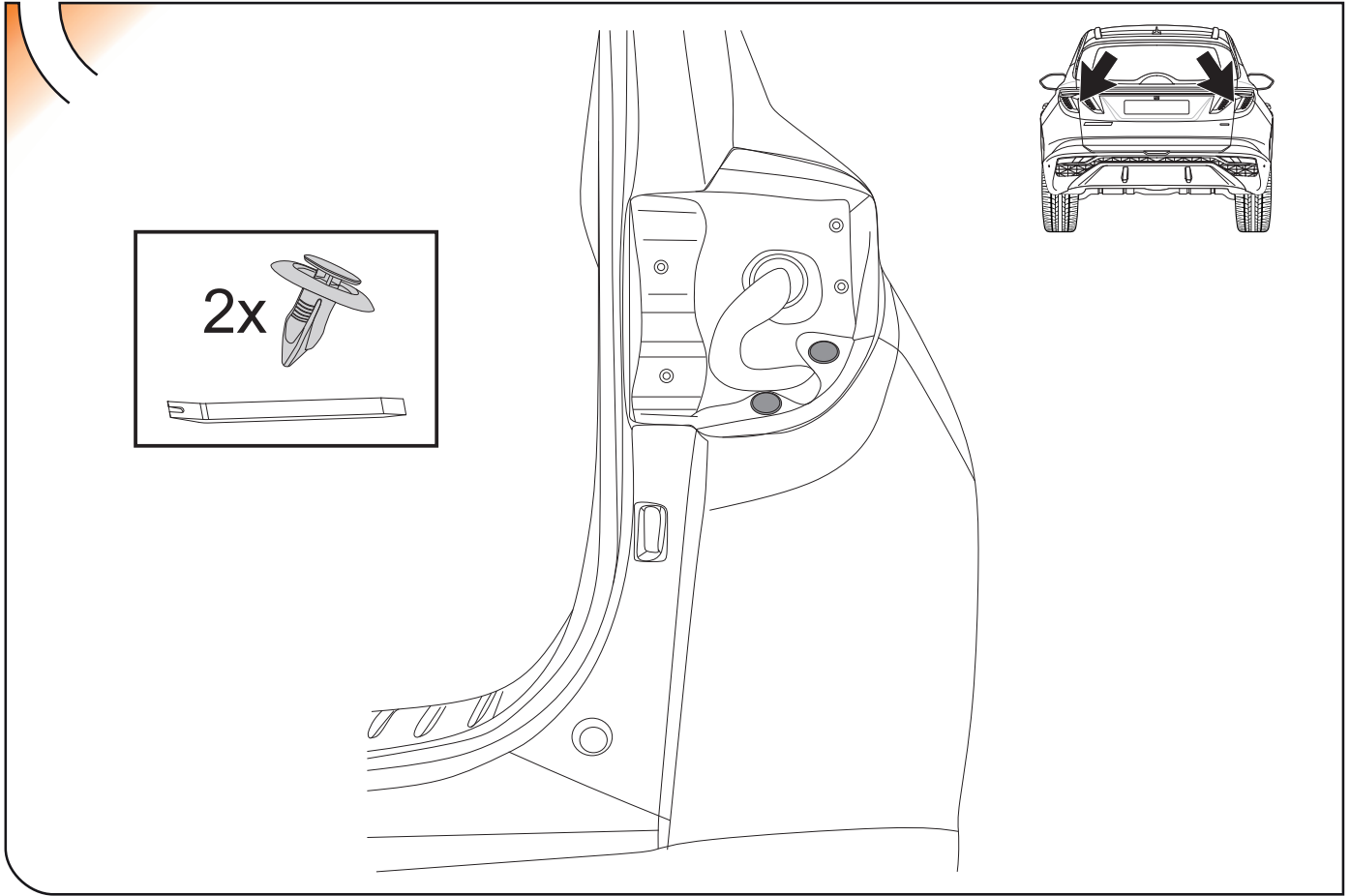

6

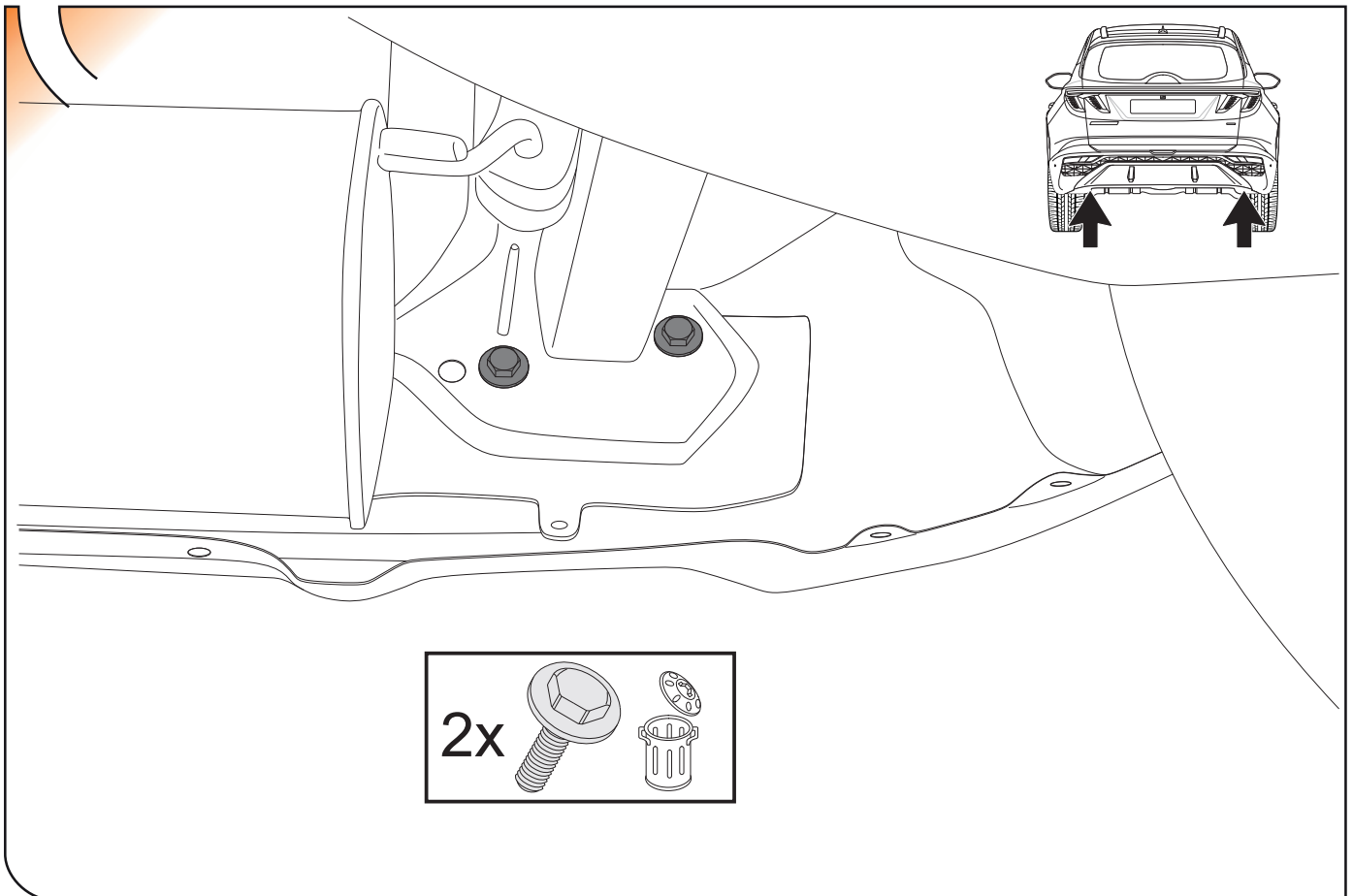

7

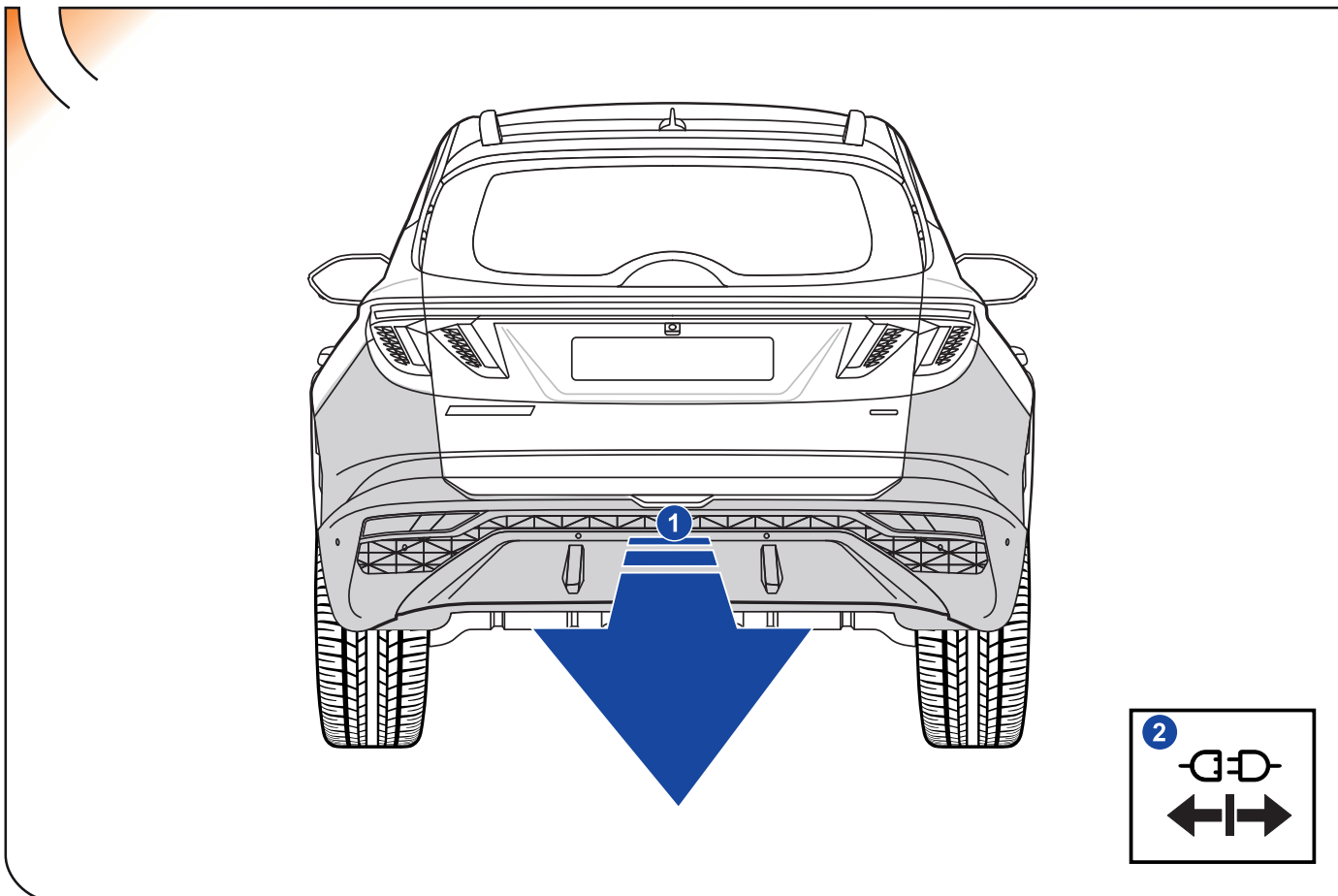

8

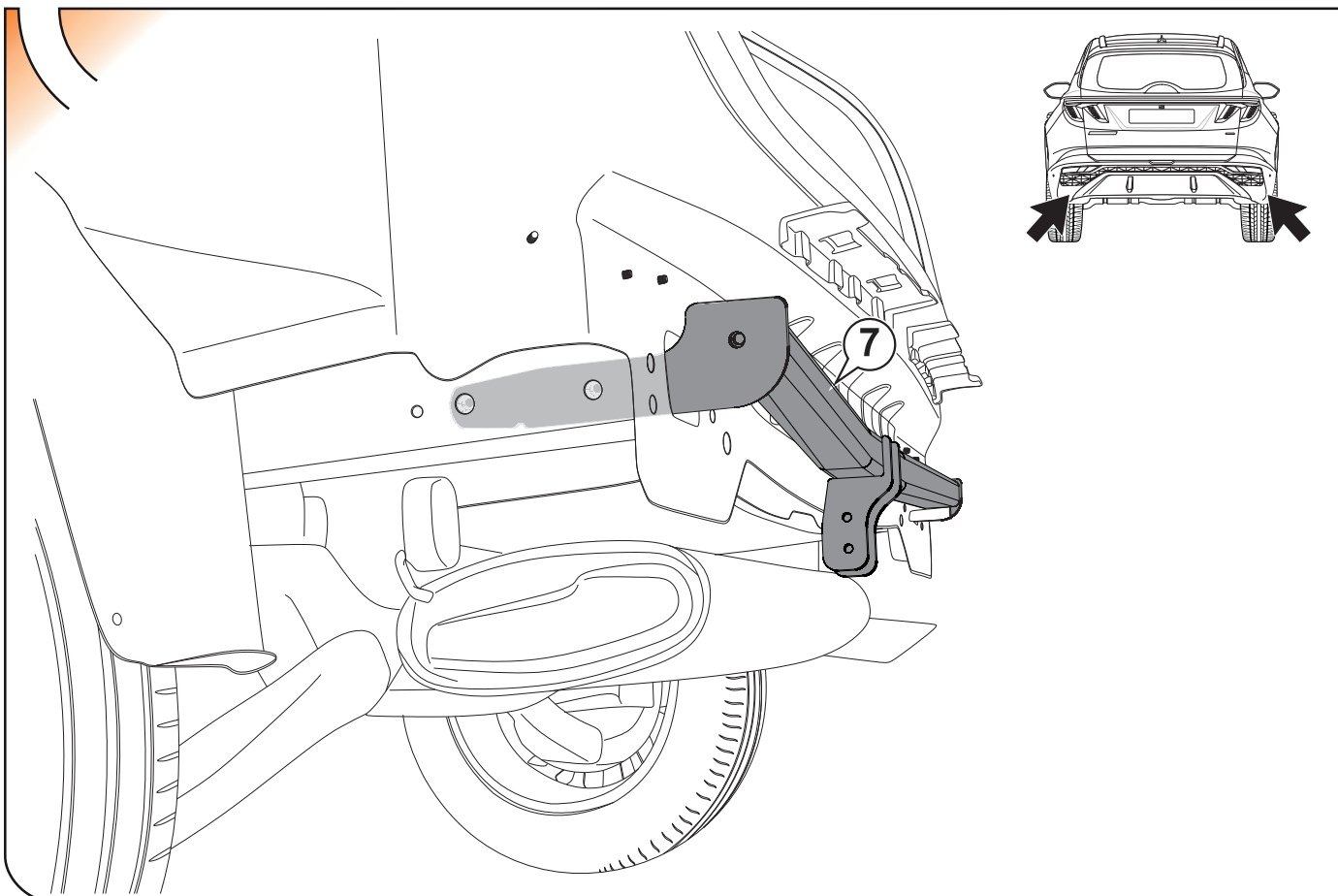

9

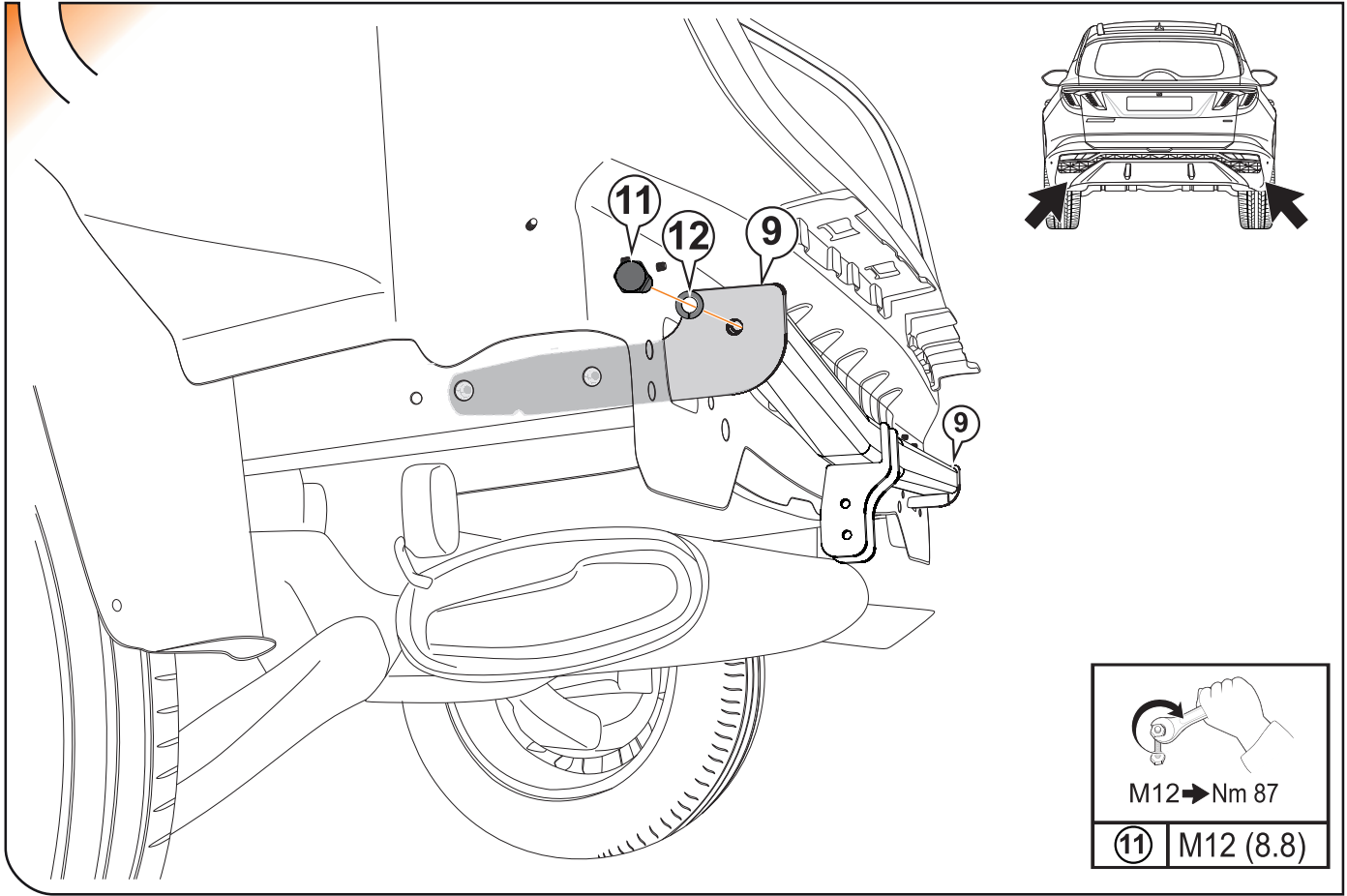

10

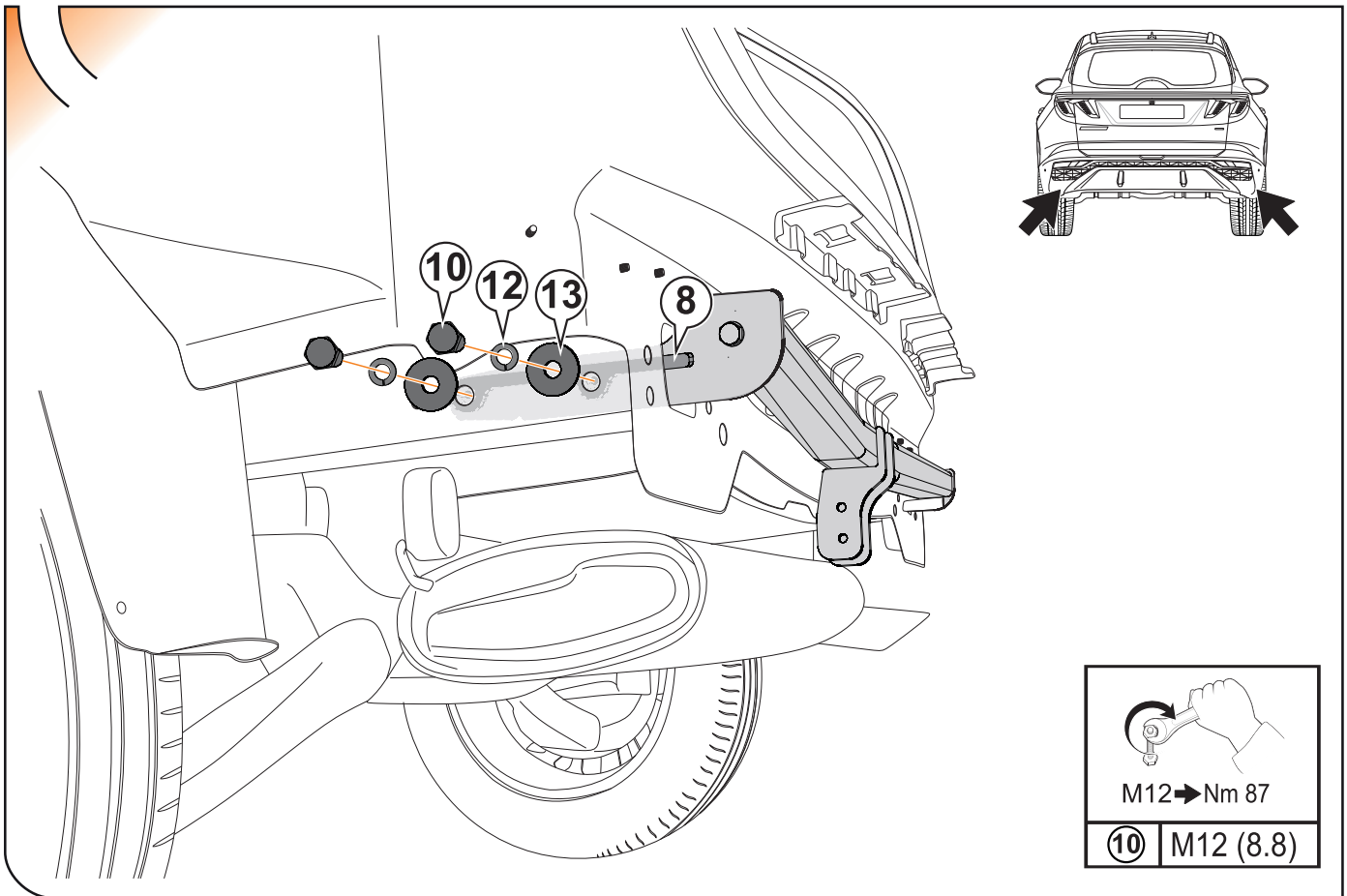

11

Hyundai Tucson

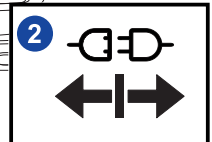
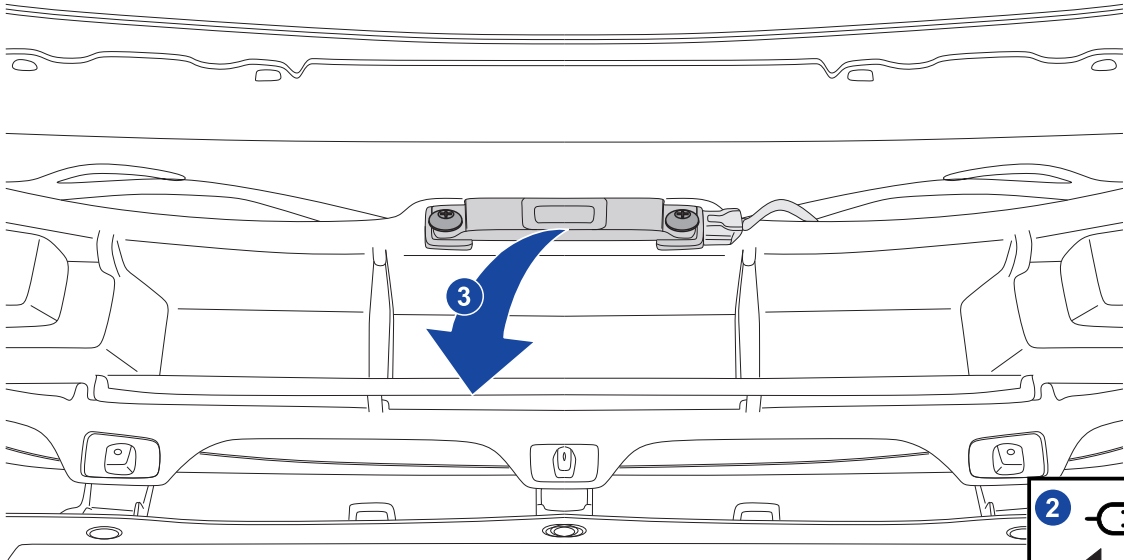
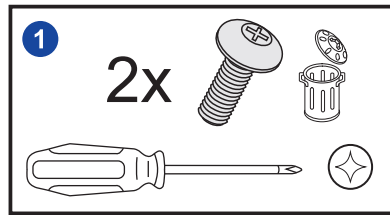

12

Hyundai Tucson

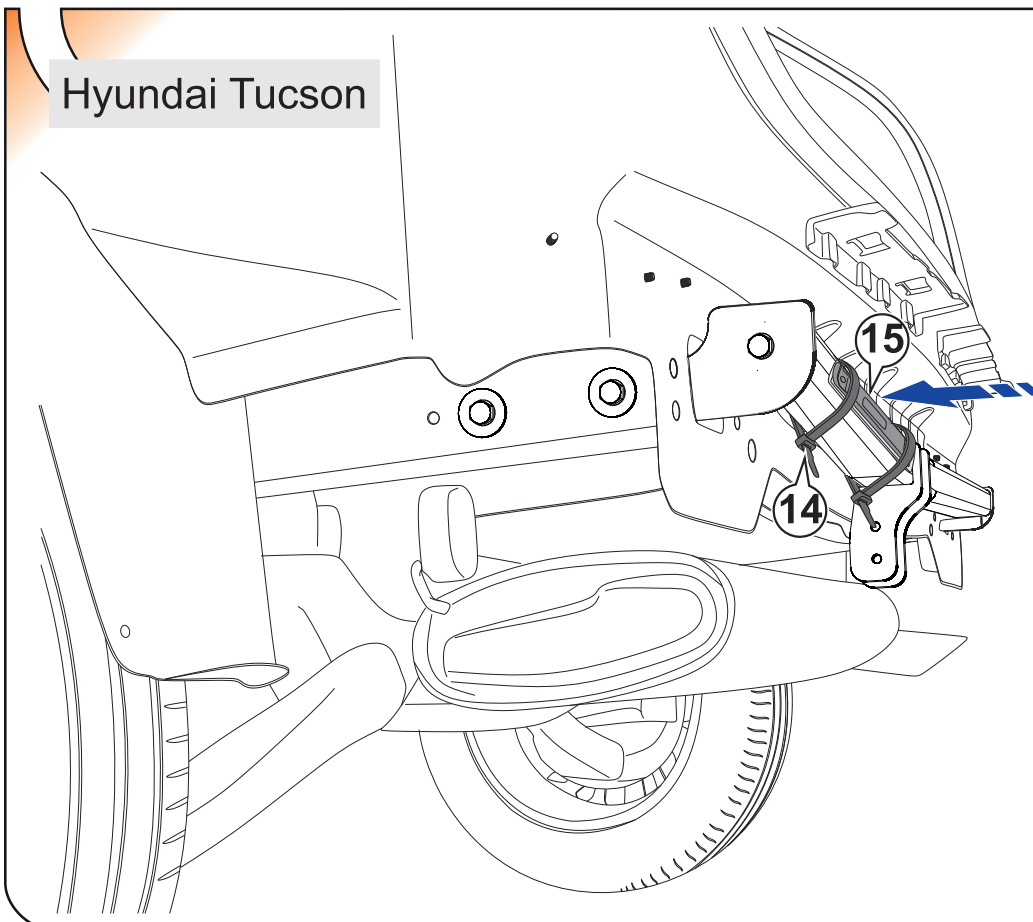
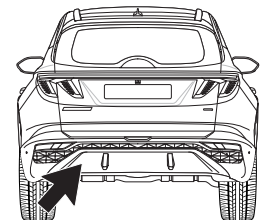

13

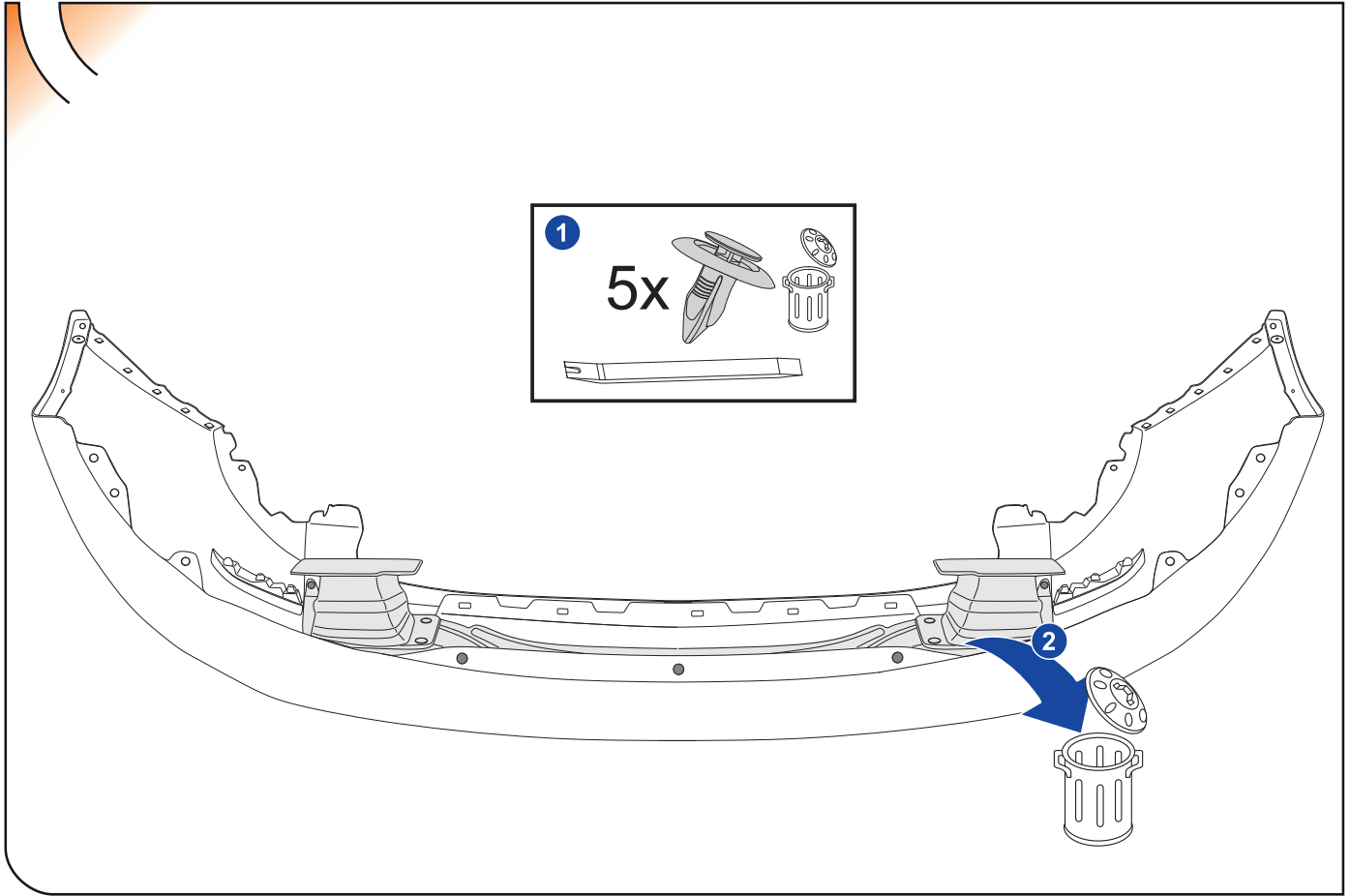

14

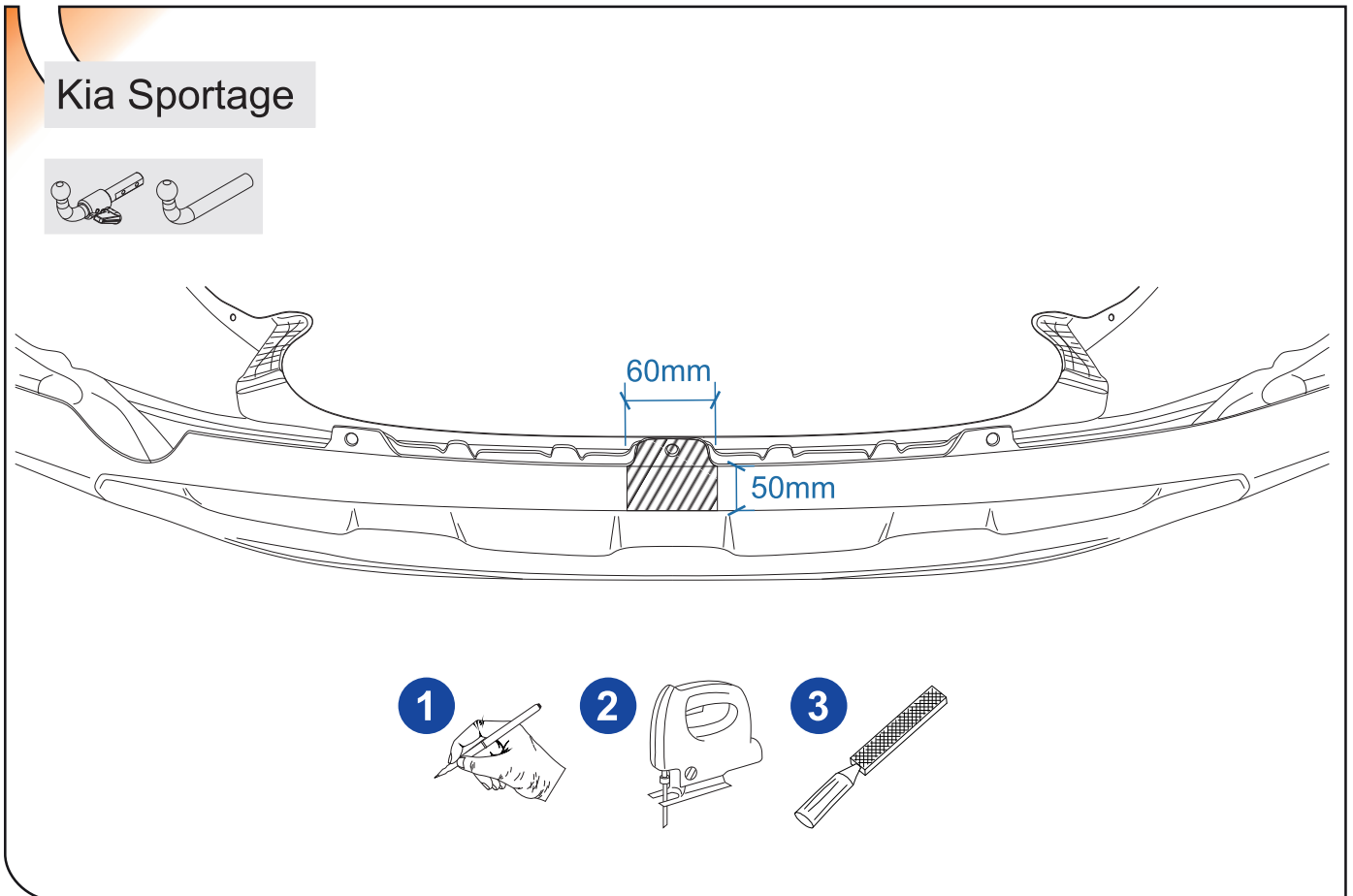

15

Kia Sportage

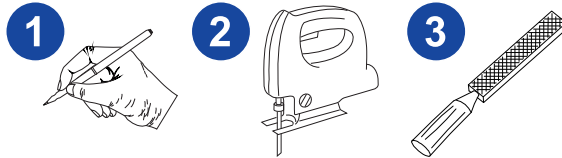
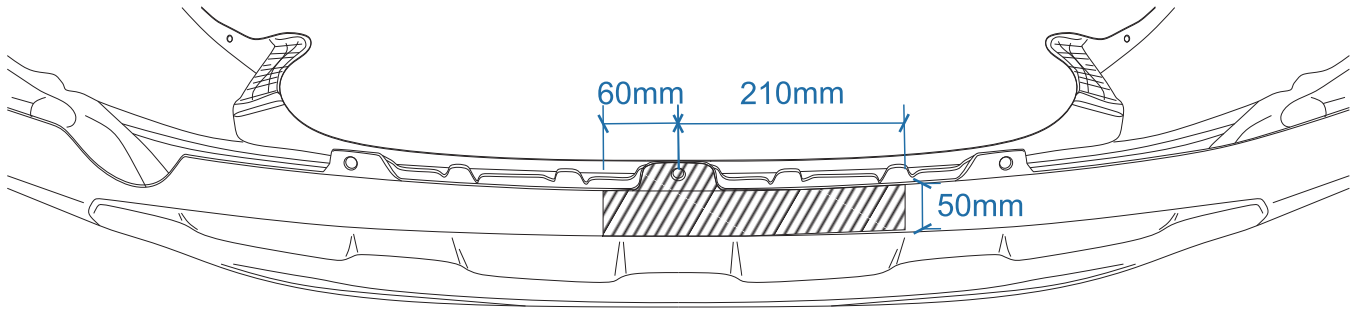
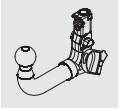

16

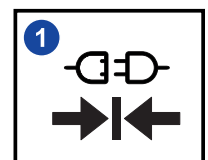
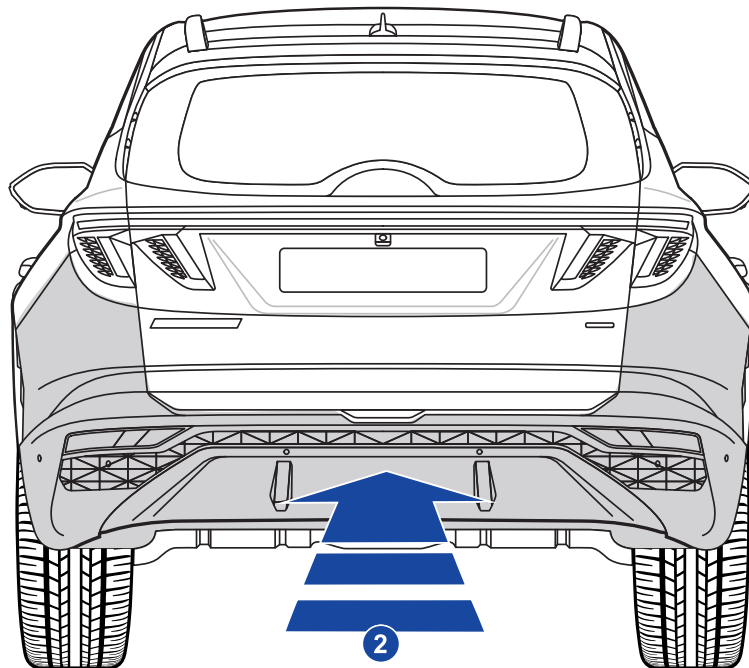

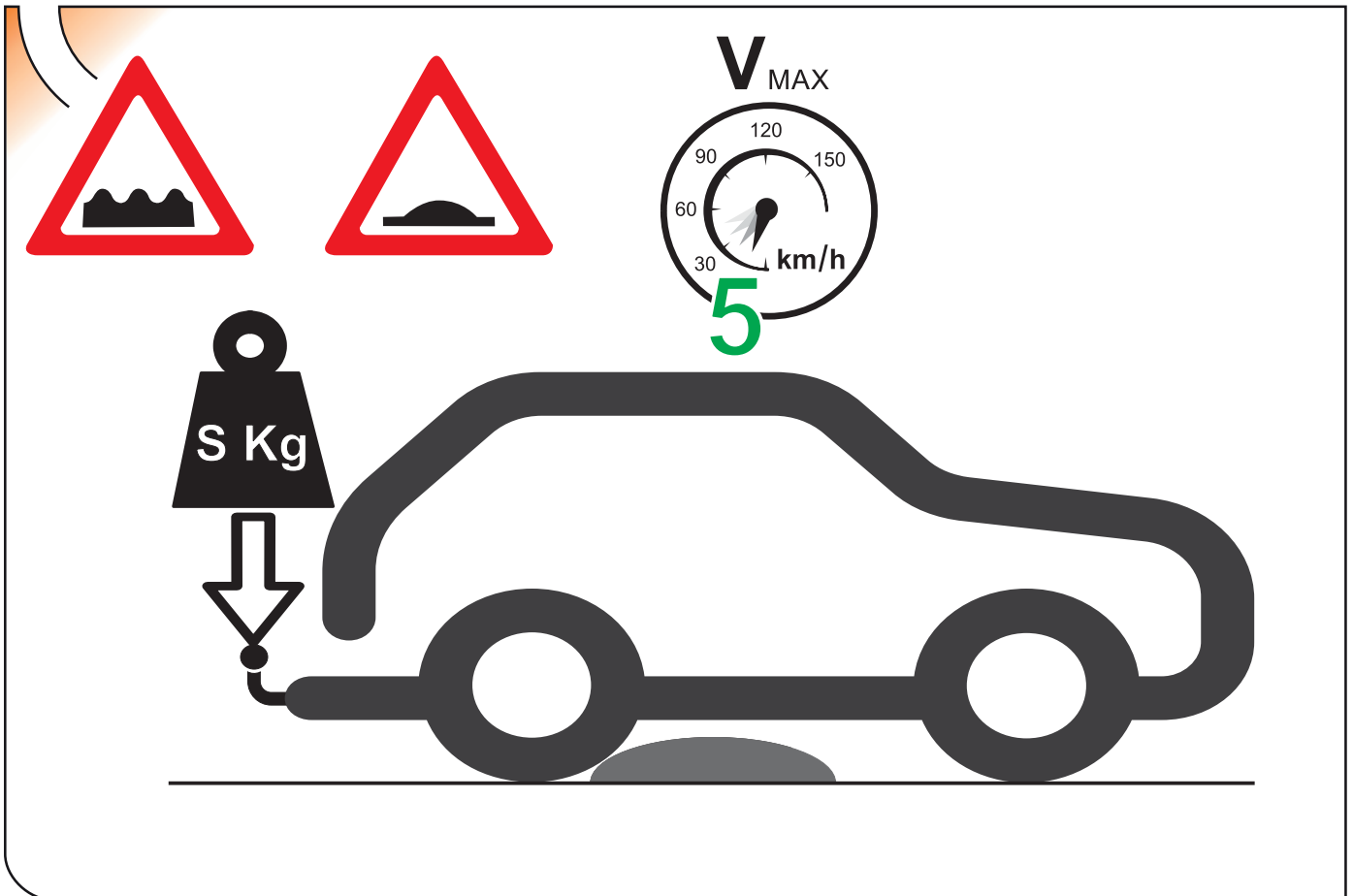
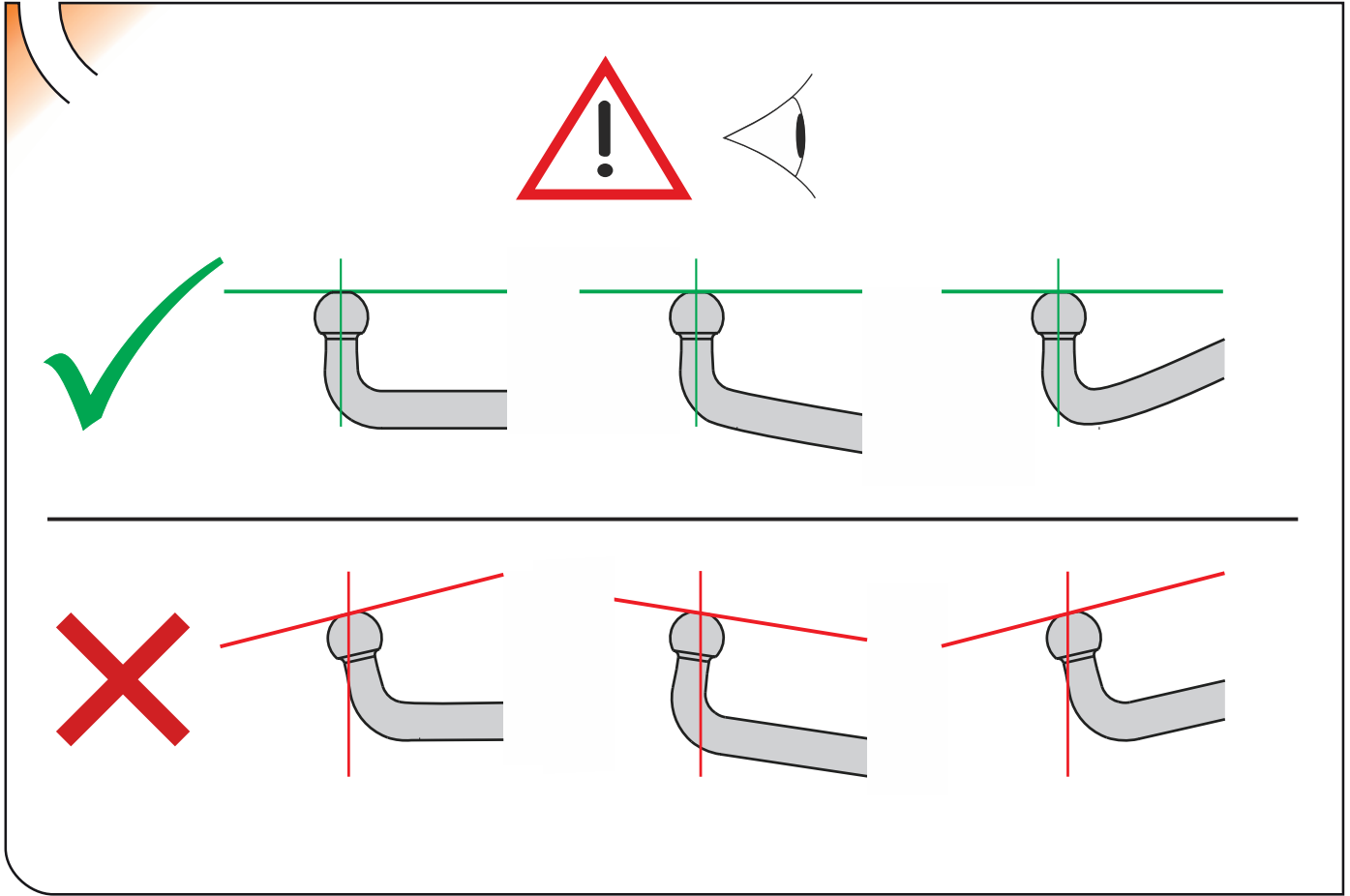

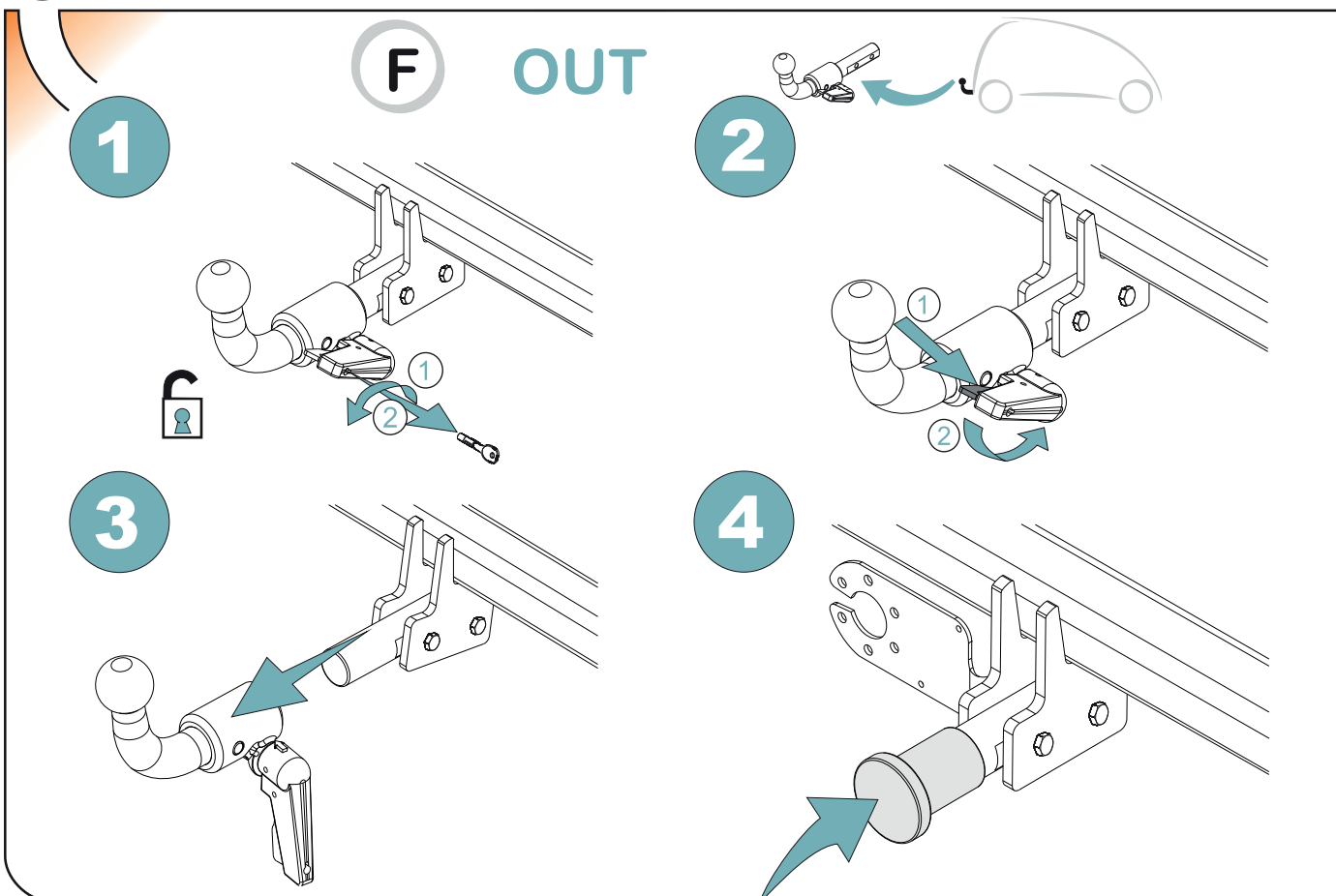
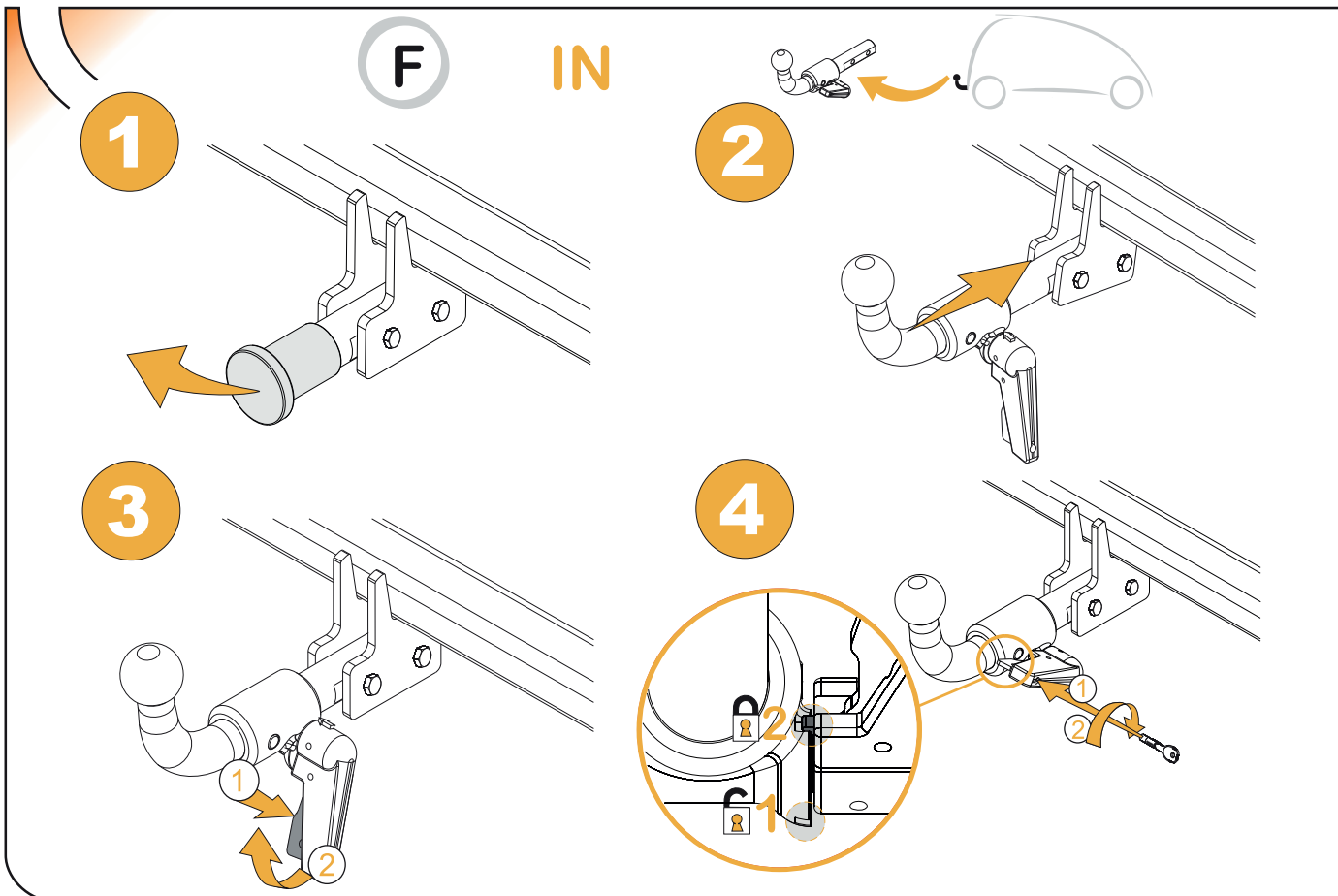

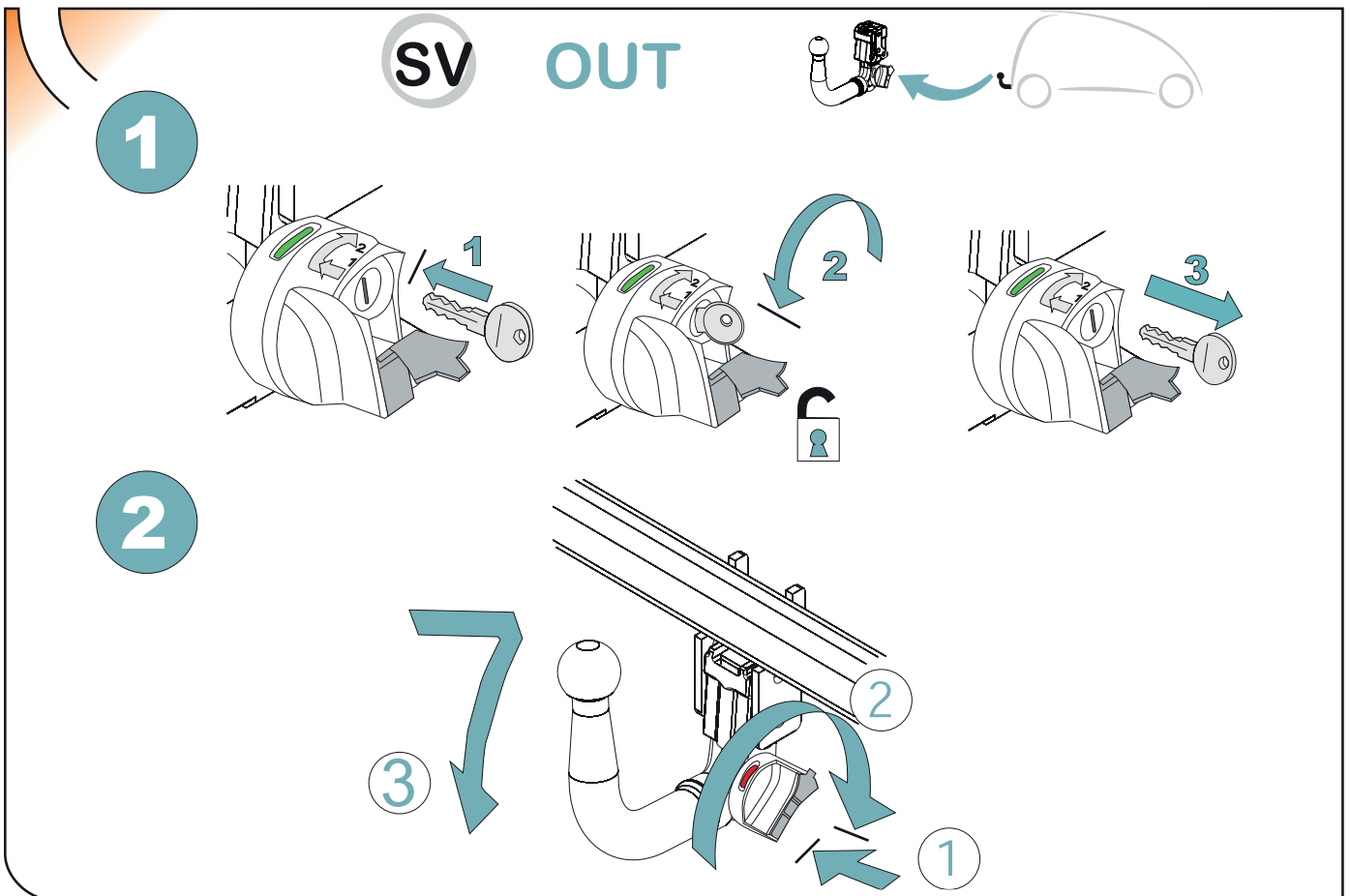
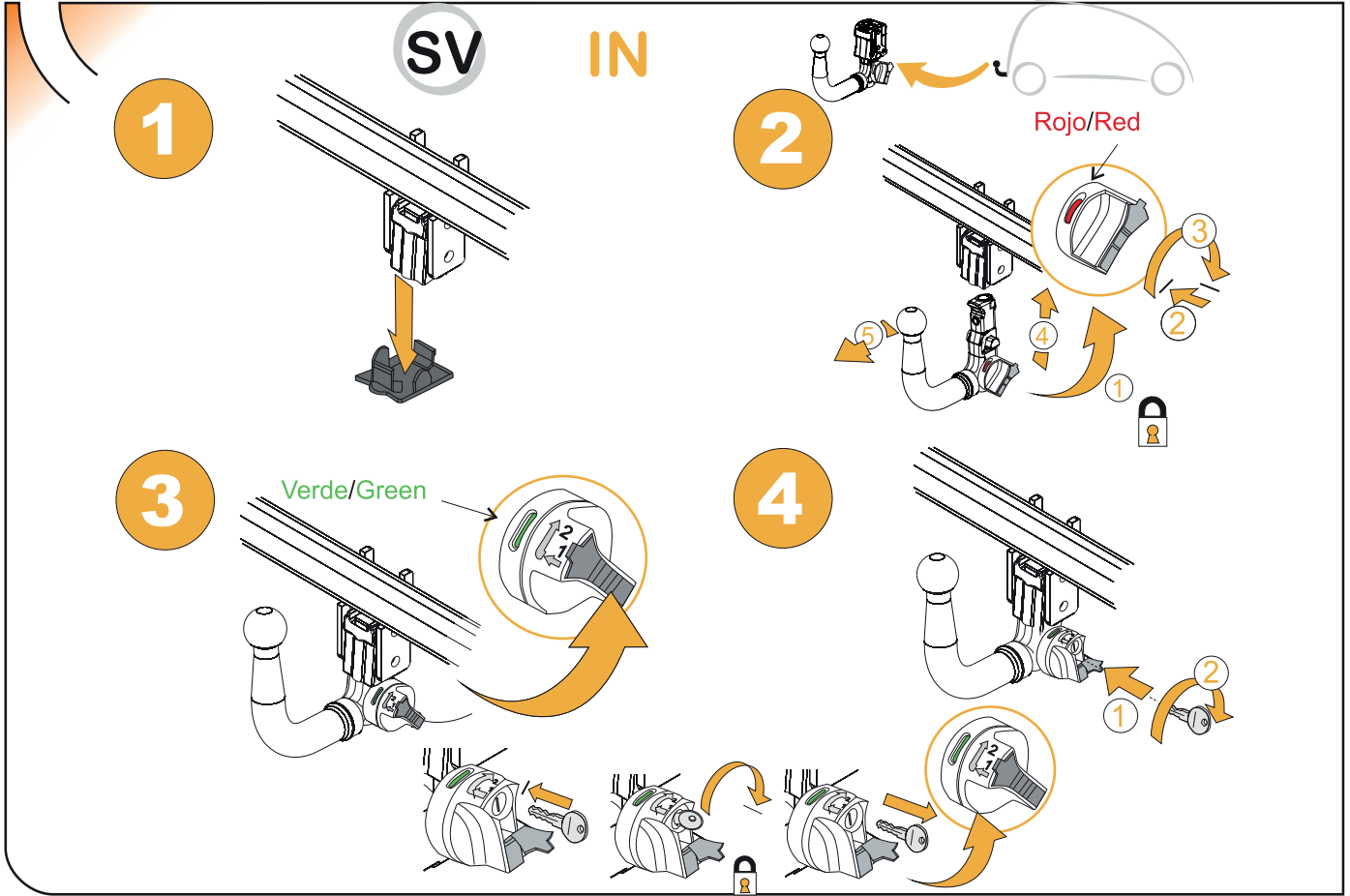

ANEXO III

CERTIFICADO DE TALLER

D. _____, expresamente autorizado por la empresa _____
domiciliada en _____, teléfono _____, dedicada
a la actividad de _____ n° de Registro Industrial _____ y n° de registro
especial (1)_____.

CERTIFICA

Que la mencionada empresa ha realizado la/s Reforma/s y asume la responsabilidad de la ejecución,
sobre el vehículo marca....., tipo.....
variante..... denominación comercial
matrícula y n° de bastidor, de acuerdo con:

- La normativa vigente en materia de reformas de vehículos.
- Las normas del fabricante del vehículo aplicables a la/s reforma/s llevadas a cabo en dicho vehículo.
- El proyecto descriptivo de la/s reforma/s, adjunto al expediente.

OBSERVACIONES: (2)

Tipificada/s con el código de reforma/s.....
Reforma consiste en:

COLOCACION DE ENGANCHE HOMOLOGADO EUROPEO MARCA:

n° de identificación / marca de homologación:

Type :

Garantizo que se cumple lo previsto en el artículo 6 del Reglamento General de vehículos y, en su caso, en el artículo 9 del R.D. 1457/1986, de 10 de enero, por el que se regula la actividad industrial en talleres de vehículos automóviles, de equipos y sus componentes, modificado por 455/2010 de 16 de abril.

....., a.....de.....de

Firma y sello:

(1) En el caso de que la reforma sea efectuada por el fabricante se indicará N/A.

(2) Se debe especificar en este apartado OBSERVACIONES, la identificación de los equipos o sistemas modificados.

ES

1



2



3



IT

1

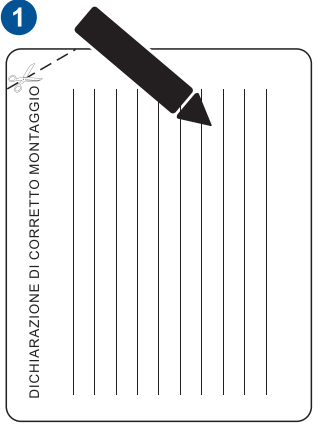

2

