



2001 - 2007

JEEP CHEROKKE LIBERTY

Cat. No. **J/026**

e20

e20*94/20*0324*00

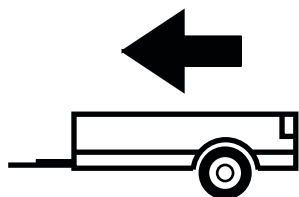

3500Kg

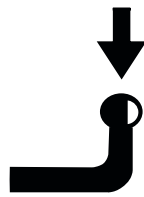

140Kg

D = 14,40kN

D (kN) = $\frac{\text{MAX kg} \times \text{MAX kg}}{\text{MAX kg} + \text{MAX kg}} \times 0,00981$

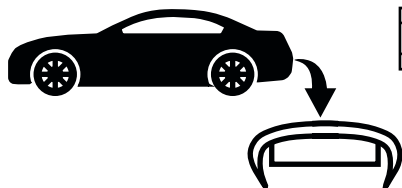

IMIOLA HAK-POL

96-111 KOWIESY, CHOJNATA 23A, POLAND

Tel. + 48 46 831 73 31, fax +48 831 74 29

e-mail: office@imiola.pl, www.imiola.pl

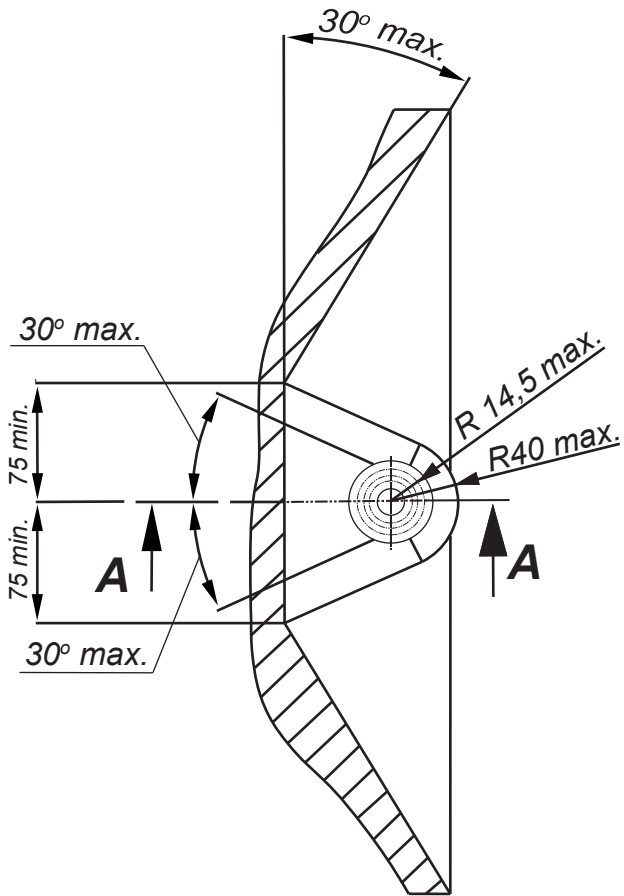

PRZEKRÓJ A-A

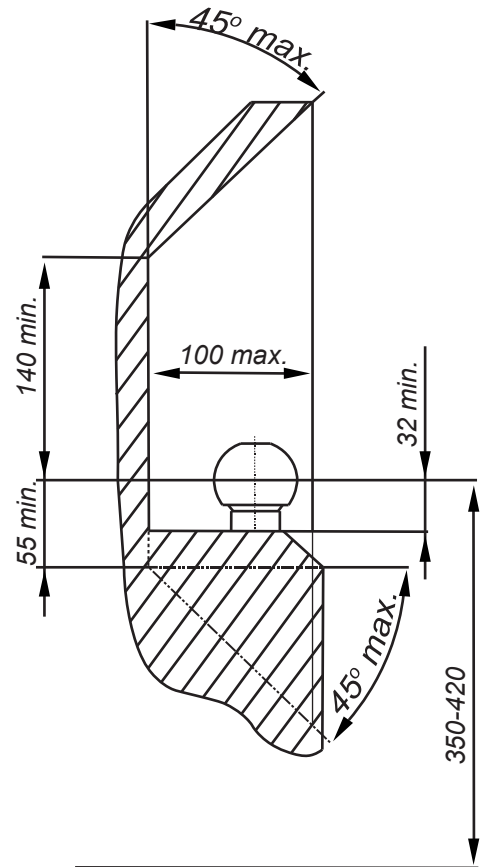

PL Należy zagwarantować przestrzeń swobodną według załącznika VII, rysunek 25a/b Regulaminu EKG ONZ 55.01 przy dopuszczalnym ciężarze całkowitym pojazdu.

F L'espace libre doit être garanti conformément à l'annexe VII, illustration de la réglementation 55.01 CE pour un poids total en charge autorisé du véhicule.

GB The clearance specified in appendix VII, diagram 25a/b of Regulation No. 55.01 UN EU must be guaranteed at laden weight of the vehicle.

D Der Freiraum nach Anhang VII, Abbildung 25a/b der Vorschriften 55.01 EG ist zu gew 25a/bahrleisten bei zulässigem Gesamtgewicht des Fahrzeuges.

Moment skręcący dla śrub i nakrętek (8.8) Torgue settings for nuts and bolts (8.8)	
M8	25Nm
M10	55Nm
M12	85Nm
M14	135Nm
M16	195Nm



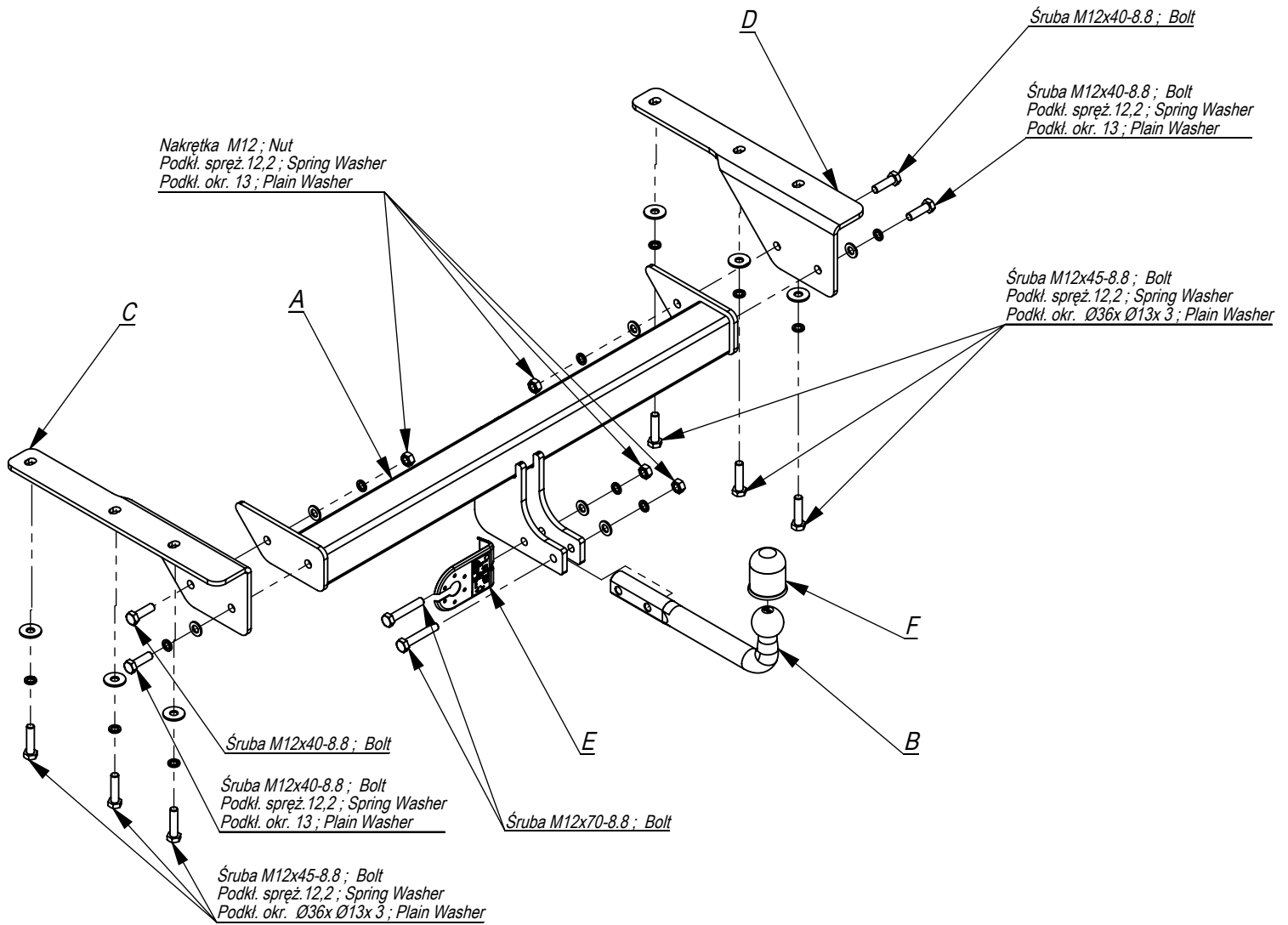

	A	x1		M12x70	2
				M12x45	6
				M12x40	4
	B	x1		M12	4
					Ø36xØ13x3
	C	x1		13	6
					12,2
	D	x1			
	E	x1			
	F	x1			

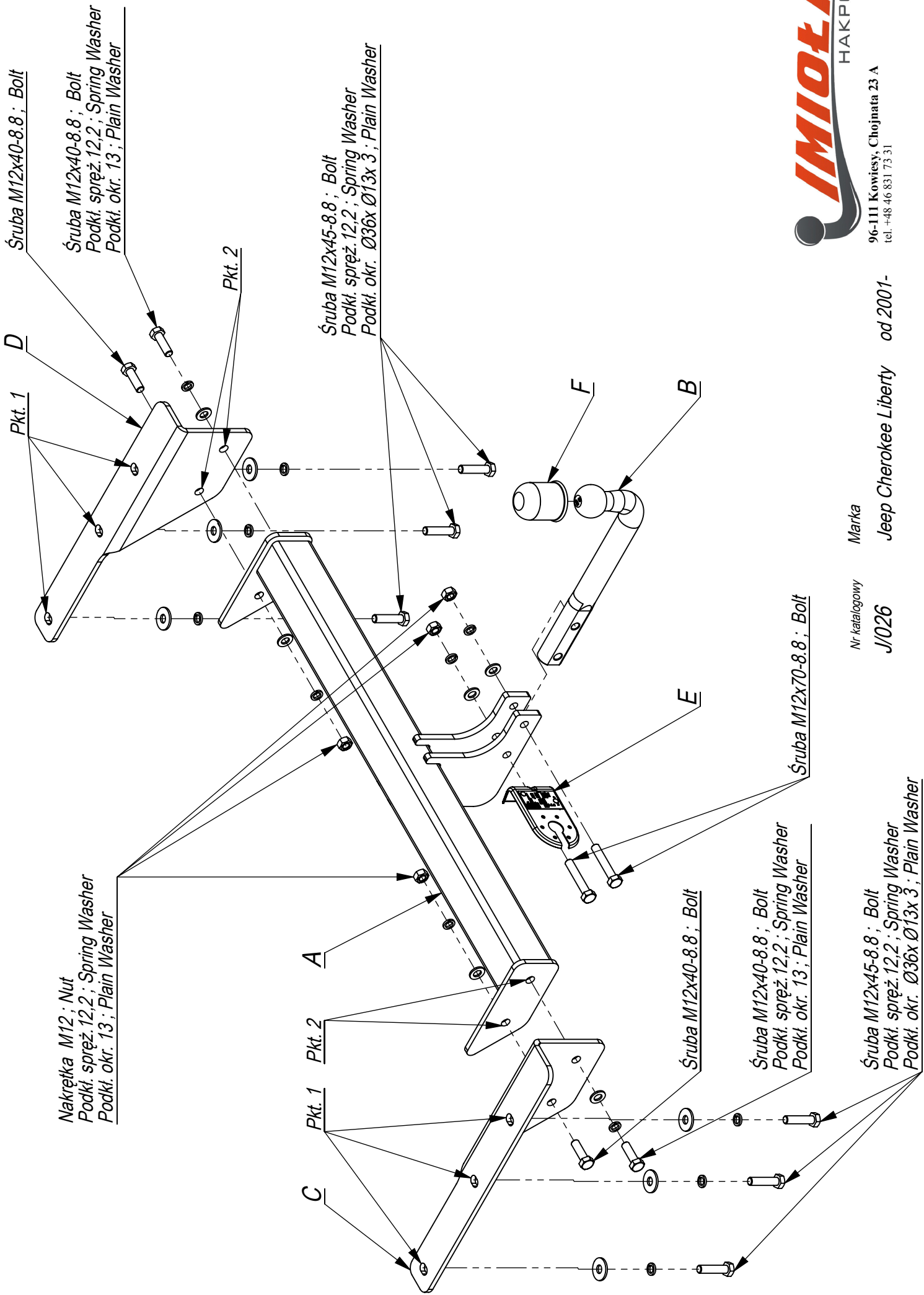

96-111 Kowiesy, Chojnata 23 A
tel. +48 46 831 73 31

Nr katalogowy
Marka

J/026

Jeep Cherokee Liberty od 2001-

- Od lewej podłużnicy odkręcić ucho holownicze (nie będzie już wykorzystane).
- Do lewej i prawej podłużnicy przykręcić, w technologiczne otwory, elementy haka C i D śrubami M12x45 8.8 (pkt 1 i 2).
- Do elementów haka B przykręcić belkę haka A śrubami M12x40 8.8 (pkt 3 i 4).
- Przykręcić kulę i blachę gniazda elektrycznego śrubami M12x70 8.8.
- Dokręcić wszystkie śruby z momentem według tabeli.
- Podłączyć instalację elektryczną.

- Unscrew the towing eye from the left metal clamp (it will not be used any more).
- Screw the elements C and D, in the technological holes, to the left and right metal clamp with bolts M12x45 8.8(point 1 and 2).
- Screw the main bar A to the elements B with bolts M12x40 8.8 (point 3 and 4).
- Fix the ball and electric plate with bolts M12x70 8.8.
- Tighten all the bolts according to the torque setting- see the table.
- Connect the electric wires.

- Dévisser l'anneau d'attelage du longeron gauche (il ne sera plus utilisé).
- Visser aux longerons, gauche et droit, dans les trous technologiques, les éléments de crochet C et D avec les boulons M12x45 8.8 (pts 1 et 2).
- Visser la barre de crochet A aux éléments de crochet B avec les boulons M12x40 8.8 (pts 3 et 4).
- Visser la boule et la tôle de la prise électrique avec les boulons M12x70 8.8.
- Serrer tous les boulons avec un couple de serrage selon tableau.
- Brancher l'installation électrique.

- Von dem linken Längsträger, die Abschleppöse abschrauben (wird nicht wieder gebraucht).
- An den linken und rechten Längsträger in die vom Werk aus vorhandenen Öffnungen die Tragteile C und D mit den Schrauben M12x45 (Punkt 1,2) anschrauben.
- An die Tragteile B den Querbalken A mit den Schrauben M12x40 8.8 (Punkt 3,4) anschrauben.
- Die Kugel und die Steckdosenhalterung mit den Schrauben M12x70 8.8 anschrauben.
- Alle Schrauben mit dem in der Tabelle angegebenen Drehmoment festziehen.
- Die Elektroinstallation anschließen.

- Desenrosque la barra de impacto (ya no es necesario).
- Fijar los elementos C y D a los largueros con tornillos M12x45 8.8 (punto 1,2).
- Apretar una barra el gancho de remolque A con los tornillos M12x40 8.8 (punto 3,4)
- Apretar todos los tornillos con el par según la tabla anterior.
- Apretar la bola y la placa de la toma eléctrica.
- Conectar la instalación eléctrica.

