



01/99-12/05

TOYOTA YARIS (C,E)

Cat. No. T/022

e20

e20\*94/20\*0751\*00

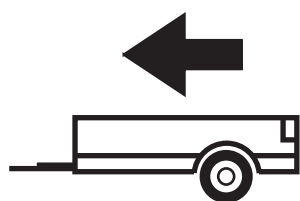

900kg



50kg

**D** = 5,37kN

**D (kN) =**



MAX kg

x

MAX kg

x 0,00981



MAX kg

+

MAX kg



IMIOLA HAK-POL

96-111 KOWIESY, CHOJNATA 23A, POLAND

Tel. + 48 46 831 73 31, fax +48 831 74 29

e-mail: office@imiola.pl, www.imiola.pl

## PRZEKRÓJ A-A

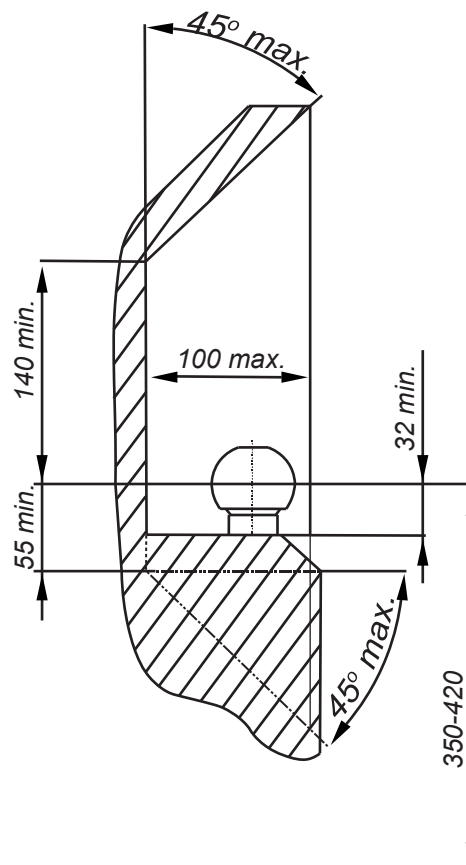
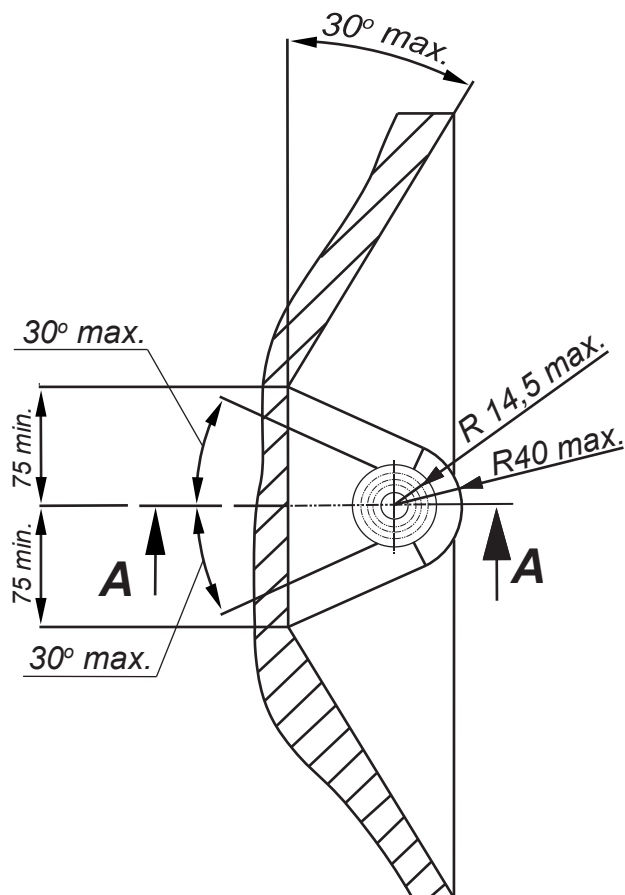

**PL** Należy zagwarantować przestrzeń swobodną według załącznika VII, rysunek 25a/b Regulaminu EKG ONZ 55.01 przy dopuszczalnym ciężarze całkowitym pojazdu.

**F** L'espace libre doit être garanti conformément à l'annexe VII, illustration de la réglementation 55.01 CE pour un poids total en charge autorisé du véhicule.







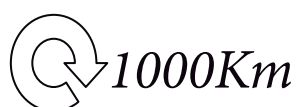

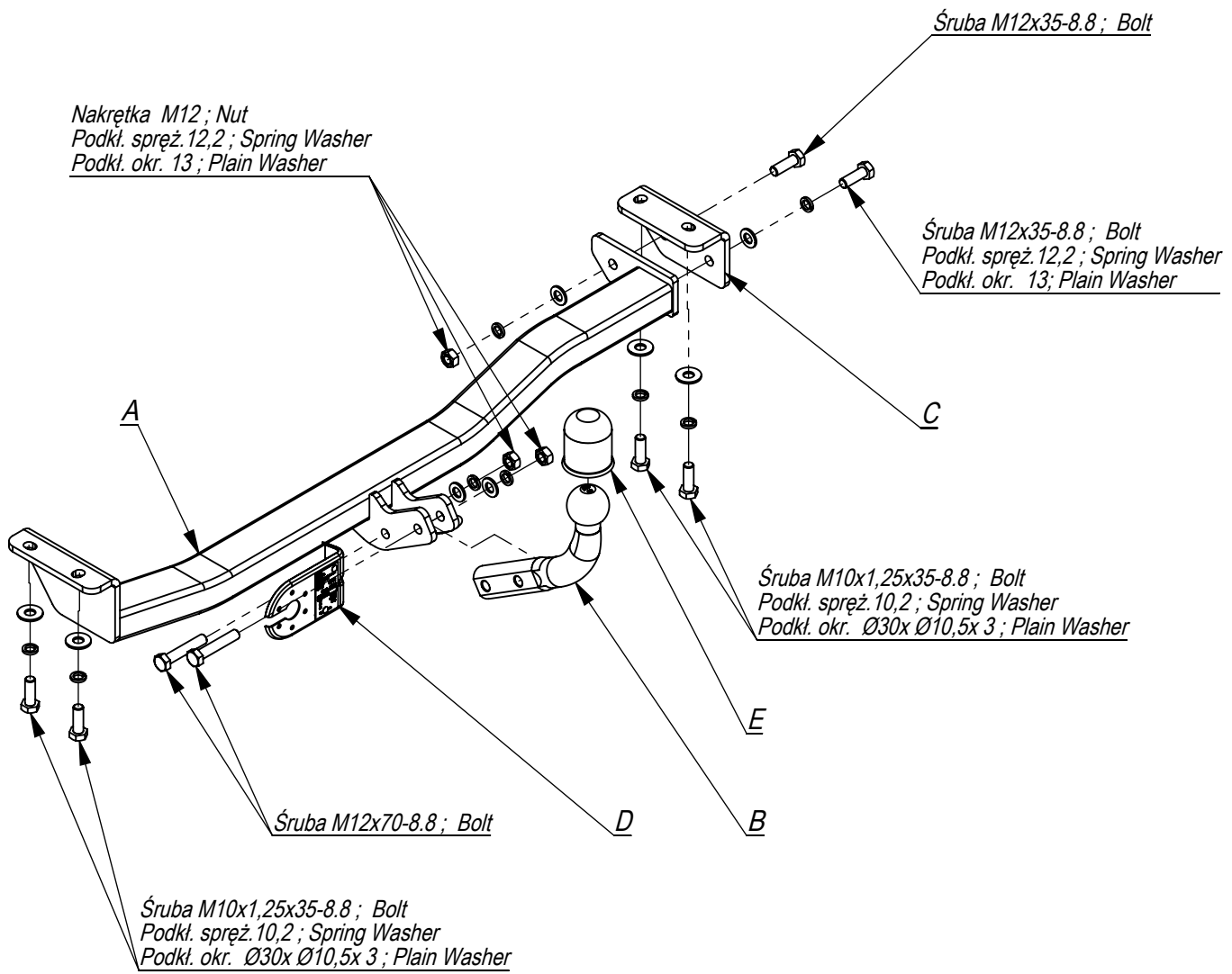

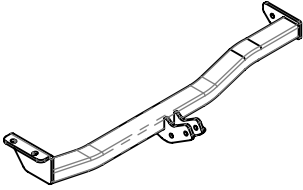
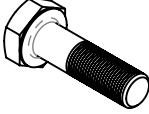

**GB** The clearance specified in appendix VII, diagram 25a/b of Regulation No. 55.01 UN EU must be guaranteed at laden weight of the vehicle.

**D** Der Freiraum nach Anhang VII, Abbildung 25a/b der Vorschriften 55.01 EG ist zu gewährleisten bei zulässigem Gesamtgewicht des Fahrzeuges.

Moment skręcający dla śrub i nakrętek (8.8) Torque settings for nuts and bolts (8.8)	
M8	25Nm
M10	55Nm
M12	85Nm
M14	135Nm
M16	195Nm





	A	x1		M12x70	2
				M12x35	2
				M10x1,25x35	4
	B	x1		M12	3
					Ø30xØ10,5x3
	C	x1		13	4
					12,2
	D	x1		10,2	4
					
	E	x1			

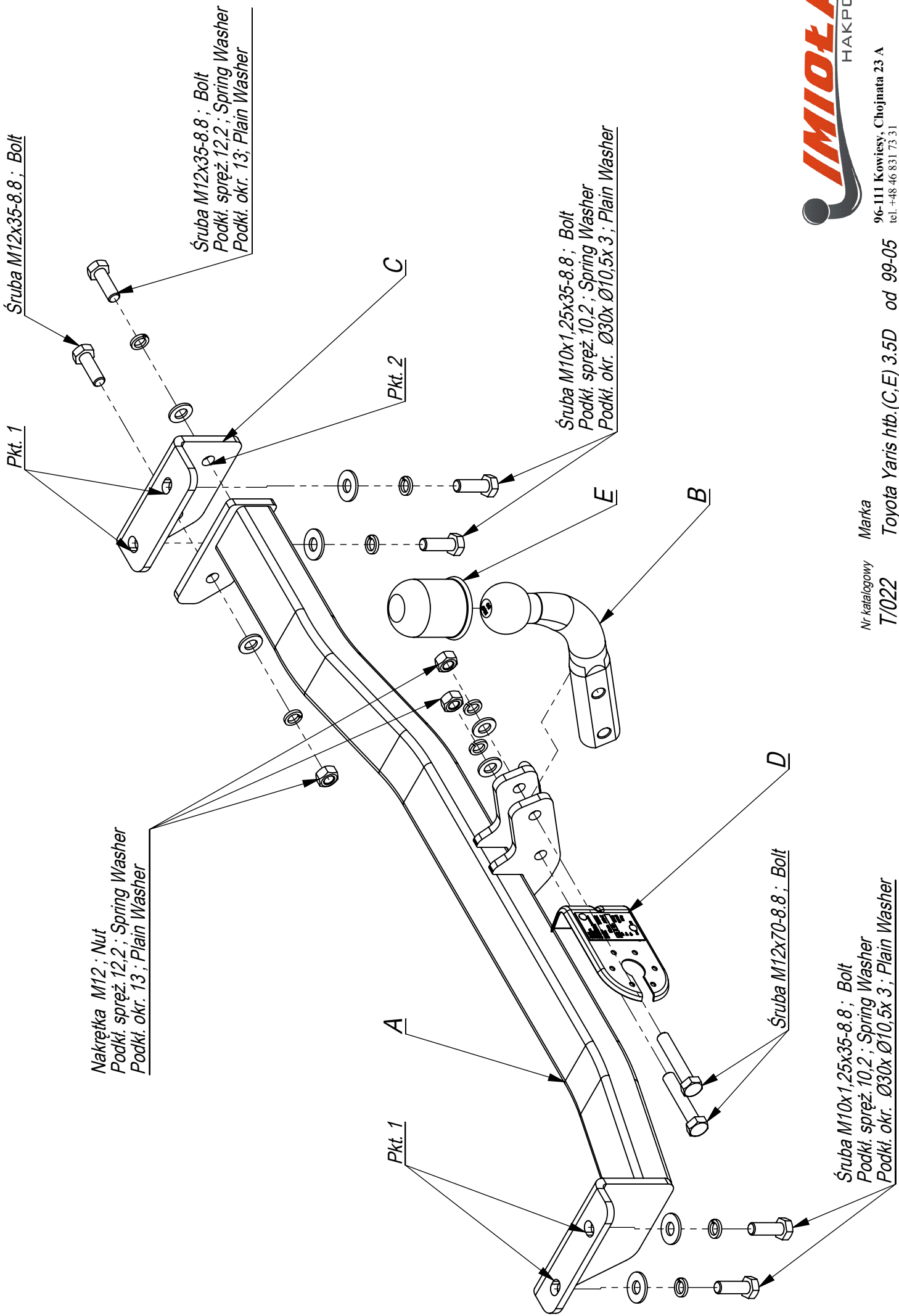

96-111 Kowiesy, Chojnata 23 A  
 tel. +48 46 831 73 31

Nr katalogowy **T/022**  
 Marka **Toyota Yaris htb.(C,E) 3.5D** od **99-05**

Śruba M12x70-8.8 ; Bolt

- Odkręcić ucha holownicze.
- Przykręcić luźno belkę haka A i wspornik C w miejsca montażu uch holowniczych (pkt 1) oryginalnymi śrubami M10x35x1,25 8.8.
- Przykręcić luźno wspornik C do belki zaczepu A śrubami M12x35 8.8 (pkt 2).
- Podłączyć instalację elektryczną.
- Przykręcić kulę i podstawę gniazda elektrycznego.
- Dokręcić wszystkie śruby z momentem według tabeli.

- Unscrew the towing eyes.
- Screw slightly the main bar A and supporter C in the towing eyes fitting places (point 1), with original bolts M10x35x1,25 8.8.
- Screw slightly the supporter C to the main bar A with bolts M12x35 8.8 (point 2).
- Connect the electric wires.
- Fix the ball and electric plate.
- Tighten all the bolts according to the torque setting- see the table.

- Dévisser les anneaux d'attelage.
- Visser légèrement la poutre du crochet A et le support C au point de montage des anneaux d'attelage (point 1) avec des boulons originaux M10x35x1,25 8.8.
- Visser librement le support C a la poutre du crochet A avec des boulons M12x35 8.8 (point 2).
- Raccorder le circuit électrique.
- Visser le crochet d'attelage et socle de prise électrique.
- Serrer tous les boulons avec un couple de serrage selon tableau.

- Die Abschleppösen abschrauben.
- Den Querbalken a und die Stütze C in den Montagestellen der Abschleppösen (Punkt1) locker anschrauben (mit Schrauben M10x35x1,25 8.8).
- Den Querbalken a und die Stütze C in den Montagestellen der Abschleppösen (Punkt1) locker anschrauben.
- Das Tragteil C an den Querbalken A mit den Schrauben M12x35 8.8 (Punkt 2) locker anschrauben.
- Die Elektroinstallation anschließen.
- Die Kugel und die Steckdosenhalterung anschrauben.
- Alle Schrauben mit dem in der Tabelle angegebenen Drehmoment festziehen.

- Desenroscar las argollas de remolque
- Apretar una barra el gancho de remolque A a los largueros con los tornillos M10x35x1,25 8.8 (punto 1).
- Fijar los elementos C del gancho a los largueros con tornillos M10x35x1,25 (punto 1)
- Fijar el gancho A a los elementos C con tornillos M12x35 8.8 (punto 2).
- Atornille la bola y la placa de toma de corriente eléctrica. con tornillos M12x70 8.8.
- Apretar todos los tornillos al torque de acuerdo con la tabla.
- Conectar la instalación eléctrica.

