



02/08 - 12/12

DACIA SANDERO Z GAZEM

Cat. No. **G/004.1**

e20

e20* 55R-01 3236

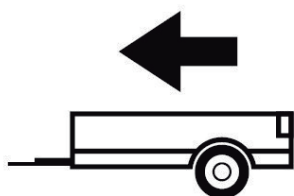

1355Kg

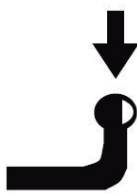

75Kg

D = 7,30kN

D (kN) =



MAX kg

x

MAX kg

x 0,00981



MAX kg

+

MAX kg

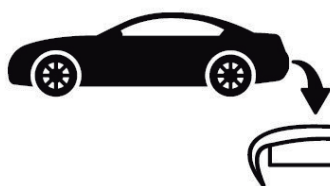

IMIOLA HAK-POL

96-111 KOWIESY, CHOJNATA 23A, POLAND

tel. +48 46 831 73 31, fax +48 831 74 29

e-mail: office@imiola.pl, www.imiola.pl

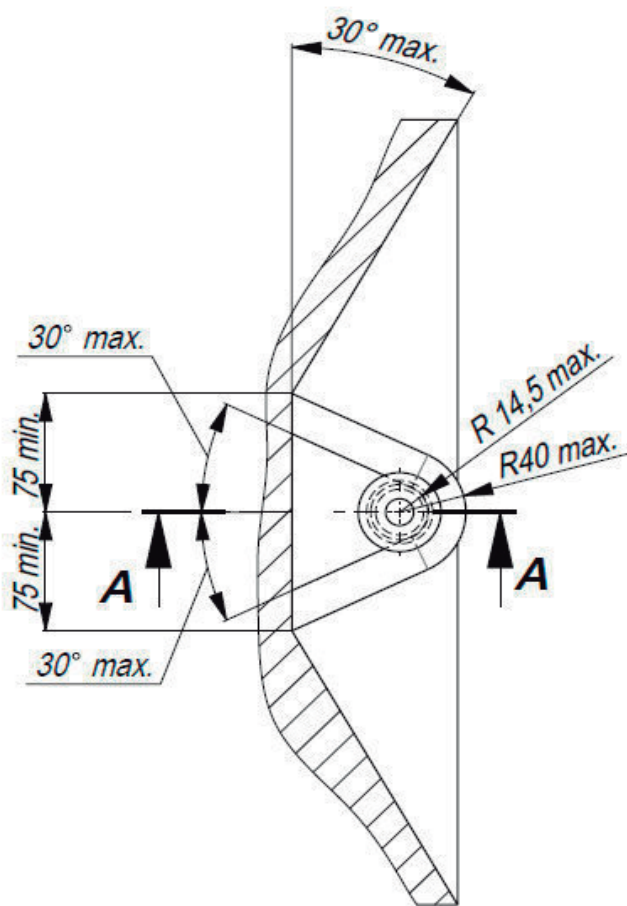

PRZEKRÓJ A-A

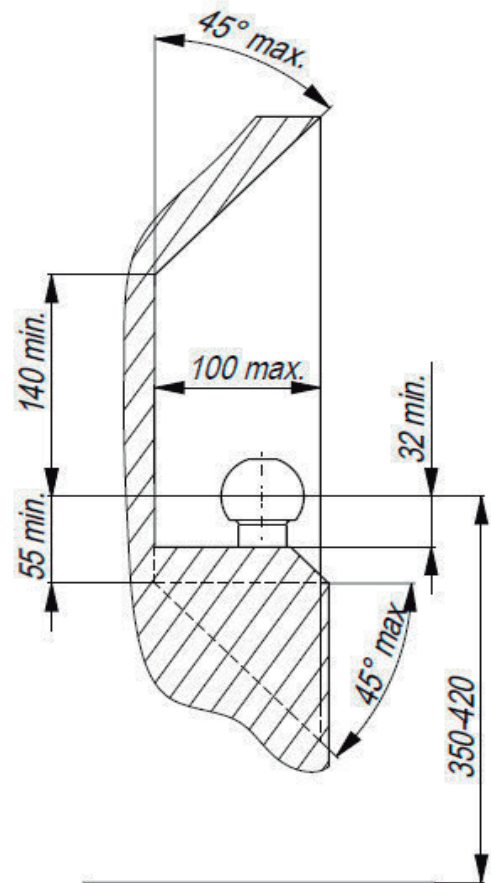

PL Należy zagwarantować przestrzeń swobodną według załącznika VII, rysunek 25a/b Regulaminu EKG ONZ 55.01 przy dopuszczalnym ciężarze całkowitym pojazdu.

F L'espace libre doit être garanti conformément à l'annexe VII, illustration de la réglementation 55.01 CE pour un poids total en charge autorisé du véhicule.

GB The clearance specified in appendix VII, diagram 25a/b of Regulation No. 55.01 UN EU must be guaranteed at laden weight of the vehicle.

D Der Freiraum nach Anhang VII, Abbildung 25a/b der Vorschriften 55.01 EG ist zu gew 25a/bahrleiten bei zulässigem Gesamtgewicht des Fahrzeuges

Moment skręcający dla śrub i nakrętek (8.8)
Torque settings for nuts and bolts (8.8)

M8	25Nm
M10	55Nm
M12	85Nm
M14	135Nm
M16	195Nm

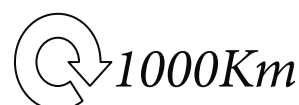

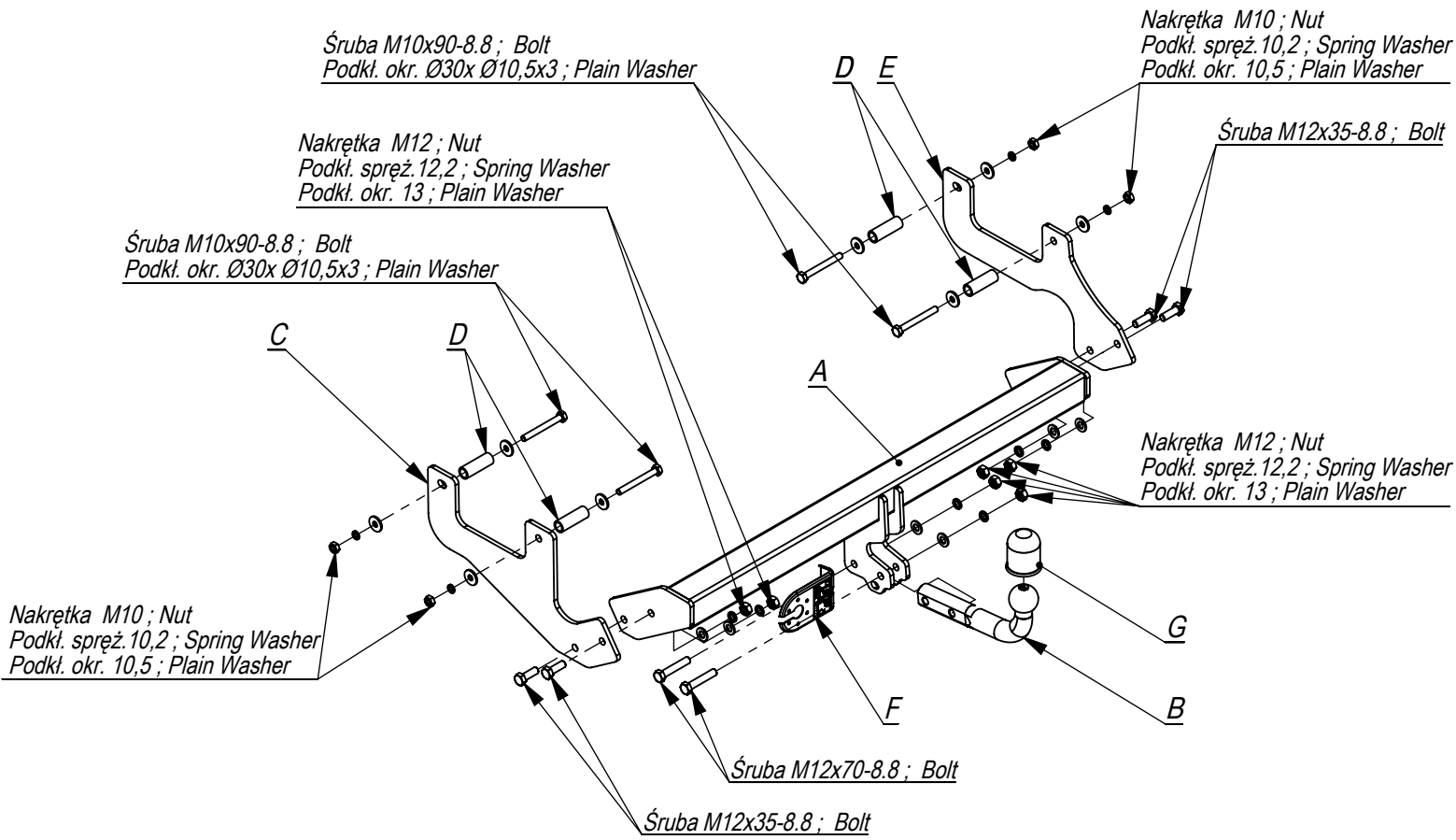

	A	x1		M12x70	2
	B	x1		M12x35	4
	C	x1		M10x90	4
	D	x4		M12	6
	E	x1		M10	4
	F	x1		Ø30xØ10,5x3	4
	G	x1		13	6
				10,5	4
				12,2	6
				10,2	4

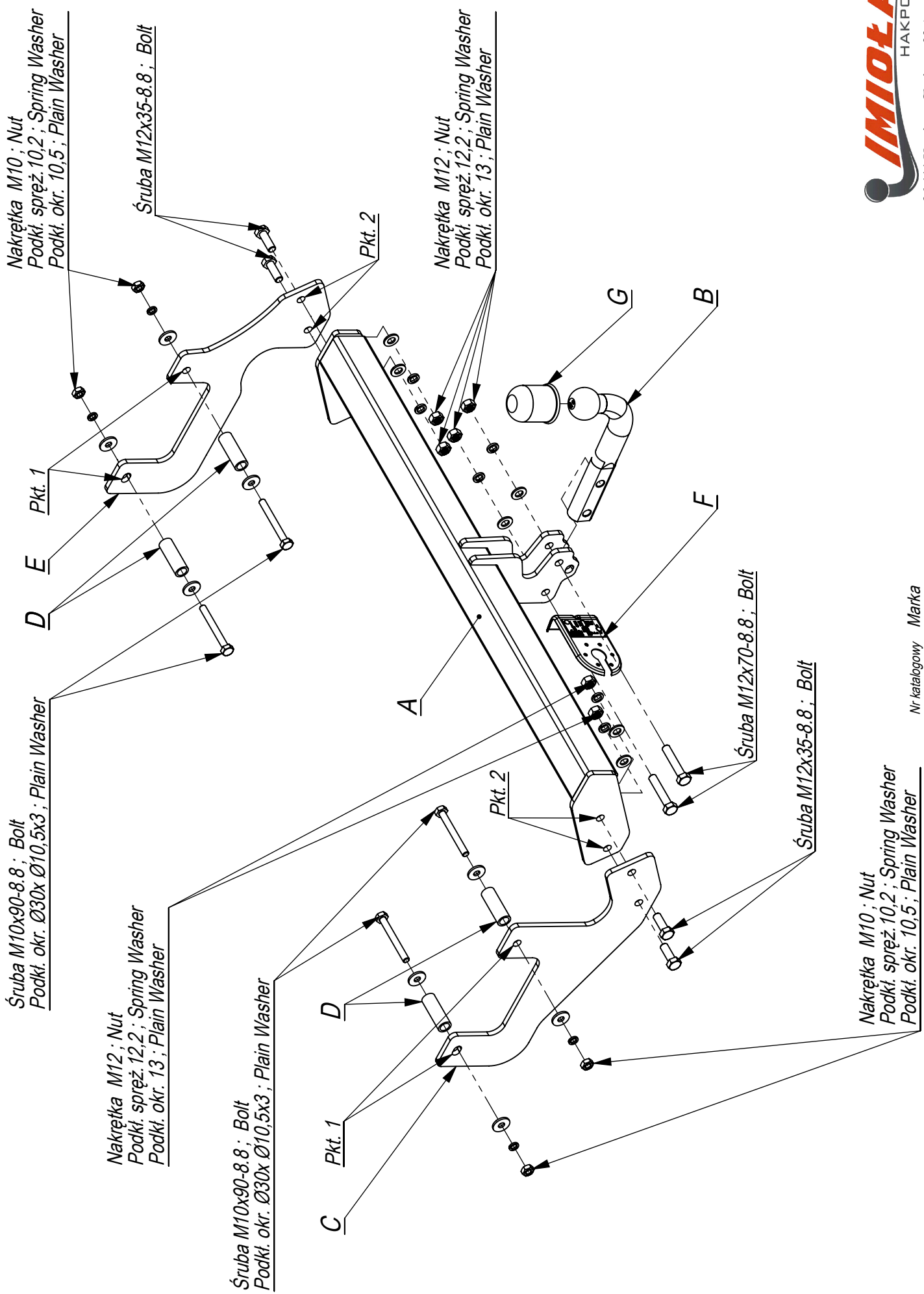

Nr katalogowy Marka

G/004.1 Dacia Sandero, Sandero z gazem od 02/08 - 12/12



96-111 Kowiesy, Chojnata 23 A
tel. +48 46 831 73 31

- Odkręcić koło zapasowe.
- Zdjąć tłumik z zawiesia i odkręcić osłonę termiczną.
- Odkręcić ucha holownicze (nie będą już wykorzystane).
- W technologiczne otwory w podłużnicach włożyć tuleje dystansowe D.
- Elementy zaczepu C przykręcić do podłużnic śrubami M10x90 8.8 (pkt 1).
- Do elementów C przykręcić belkę zaczepu A śrubami M12x35 8.8 (pkt 2).
- Dokręcić wszystkie śruby z momentem wg tabeli.
- Zamontować tłumik i przykręcić osłonę termiczną.
- Przykręcić koło zapasowe.
- Przykręcić kulę i blachę gniazda elektrycznego.
- Podłączyć instalację elektryczną.

- Unscrew the spare wheel.
- Take out the damper from the hanger and unscrew the thermal shield.
- Insert the distance sleeves D in the technological holes in the metal clamps.
- Screw the elements C to the metal clamps with bolts M10x90 8.8 (point 1).
- Screw the main bar A to the elements C with bolts M12x35 8.8 (point 2).
- Tighten all the bolts according to the torque setting- see the table.
- Assemble the damper and screw the thermal shield.
- Screw the spare wheel.
- Fix the ball and electric plate.
- Connect the electric wires.

- Placer les douilles d'écartement dans les ouvertures de longerons,
- Visser les éléments d'attache C aux longerons par les boulons M10x100, 8.8 (point 1),
- Visser les éléments C à la traverse d'attache A par les boulons M12x35 8.8 (point 2),
- Serrer tous les boulons avec un couple de serrage selon tableau,
- Visser le crochet d'attelage et socle de prise électrique,
- Raccorder le circuit électrique.

