

# Towbar

6273

SUZUKI

- Ignis 2wd MF 10/2016->

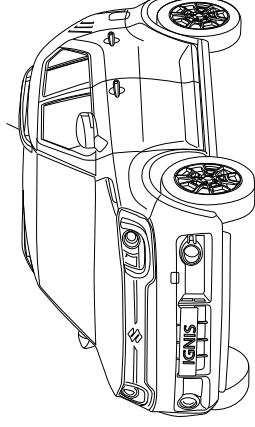

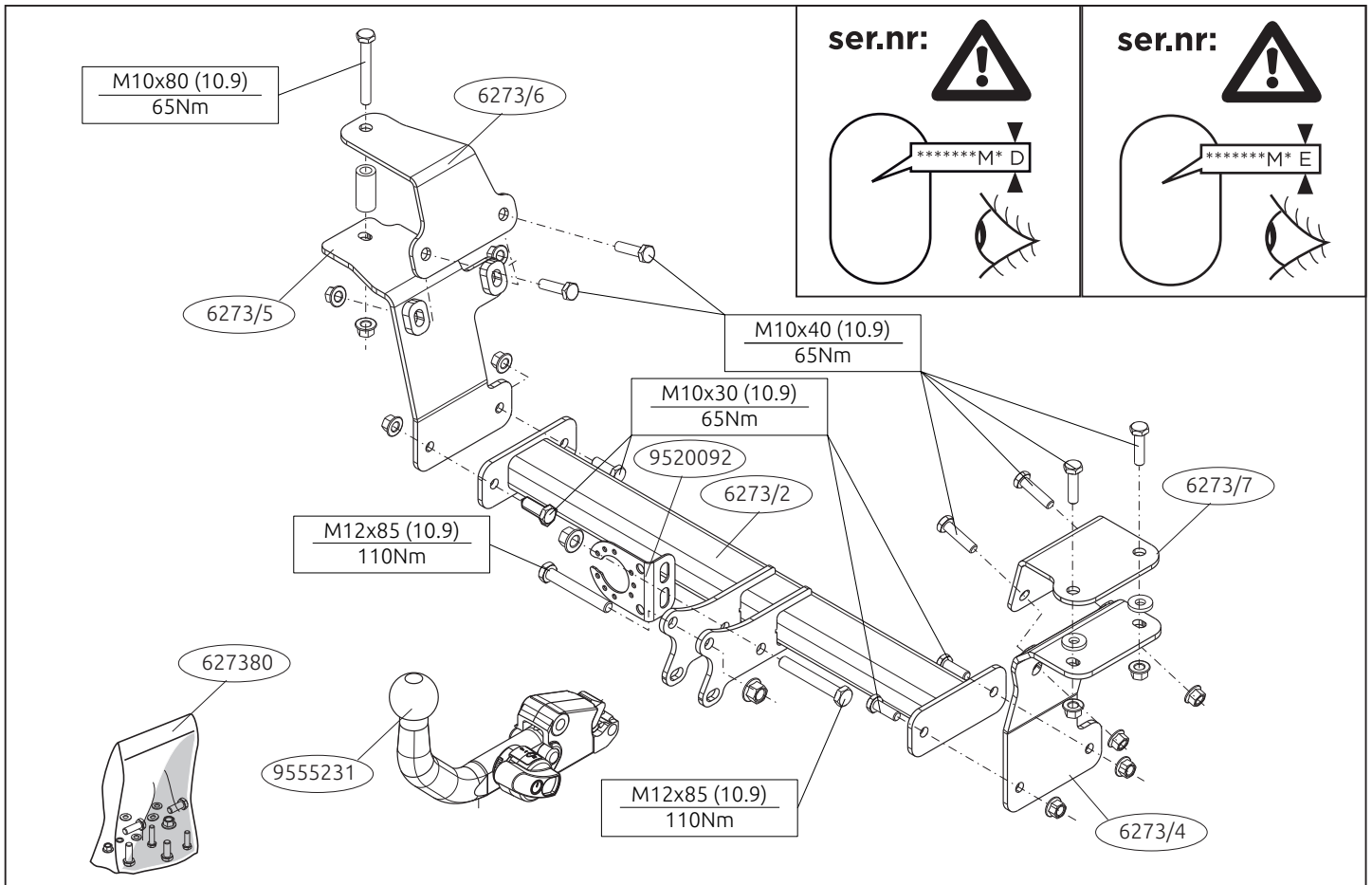

© 627370/10-08-2017/2

NL	GB	D	F	S	DK	E	I	PL	FS	CZ	H	Rus
Sjabloon	Template	Schablone	Gabarit	schablonen	skabelon	Plantilla	Sagoma	Szablon	Malline	Šablona	Sablon	Шаблон
Binnenkant bumper	Inside bumper	Innenseite Stoßstange	Intérieur du pare-chocs	Stötfångarens insida	Kofangerens inderside	Lado interior del parachoques	Lato interno del paraurti	Wewnętrzna strona zderzaka	Puskurin sisäpuolelle	Vnitř strana nárazníku	Belső lökhárító	Внутренняя сторона бампера
Buitenkant bumper	Outside bumper	Außenseite Stoßstange	Extérieur du pare-chocs	Stötfångarens utsida	Kofangerens yderside	Lado exterior del parachoques	Lato esterno del paraurti	Zewnętrzna strona zderzaka	Puskurin ulkopuolelle	Vnější strana nárazníku	Külső lökhárító	Наружняя сторона бампера
Onderkant bumper	Underside bumper / Bumper edge	Unterseite Stoßstange	Dessous du pare-chocs	Stötfångarens undersida	Kofangerens undersiden	Lado inferior del parachoques	Lato inferiore del paraurti	Spód/krawędź zderzaka	Puskurin alapuolelle	Spodní strana nárazníku	Alsó lökhárító	Нижний край бампера
Midden bumper	Middle bumper	Mitte Stoßstange	Milieu du pare-chocs	Stötfångarens mitt	Kofangerens midte	Centro del parachoques	Centro del paraurti	Środek zderzaka	Puskurin keskelle	Střed nárazníku	Középső lökhárító	Средние части бампера
Links	LHS	Links	Gauche	Vänster	Venstre	Izquierdo	Sinistra	Lewy	Vasen	Levá strana	Bal	Слева
Rechts	RHS	Rechts	Droit	Höger	Højre	Derecho	Destra	Prawy	Oikea	Pravá strana	Jobb	Справа
Uitsnijden	Cut out	Ausschneiden	Découper	Klippa ut	Skære ud	Cortar	Ritagliare	Wyciąć	Leikata	Vyřiznout	Kivágás	Вырез
Buiglijn	Bend line	Biegelinie	Ligne de pliage	Böjlinje	Bukke linie	Doblar línea	Linea di piega	Linia zagięcia	Taivutuslinja	Linie ohybu	Hajtási vonal	Линия изгиба
Koppelen	Connect	Verbinden	Connecter	Koppla in	Forbind	Conectar	Connettere	Połączyć	Kytkeä	Připojit	Csatlakozás	Соединить
Ontkoppelen	Disconnect	Abkuppeln	Déconnecter	Koppla från	Afbryd	Desconectar	Disconnettere	Odlączyć	Katkaista	Odpojit	Eltávolítás	Разъединить
zonder bumperklep	Without bumpercover	ohne Stoßstangenklappe	sans trappe de pare-chocs	utan täckplåt	uden dækplade i stødfangeren	sin tapa parachoques	senza copripaurti	bez osłony zderzaka	ole puskurinsa suojukslevyä	bez krytu nárazníku	nélkül lökhárító burkolat	без кожуха бампера

© 627370/10-08-2017/19

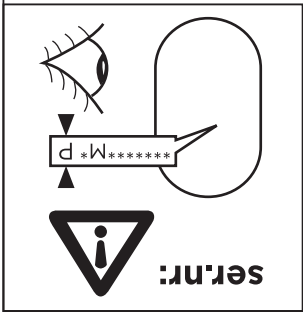
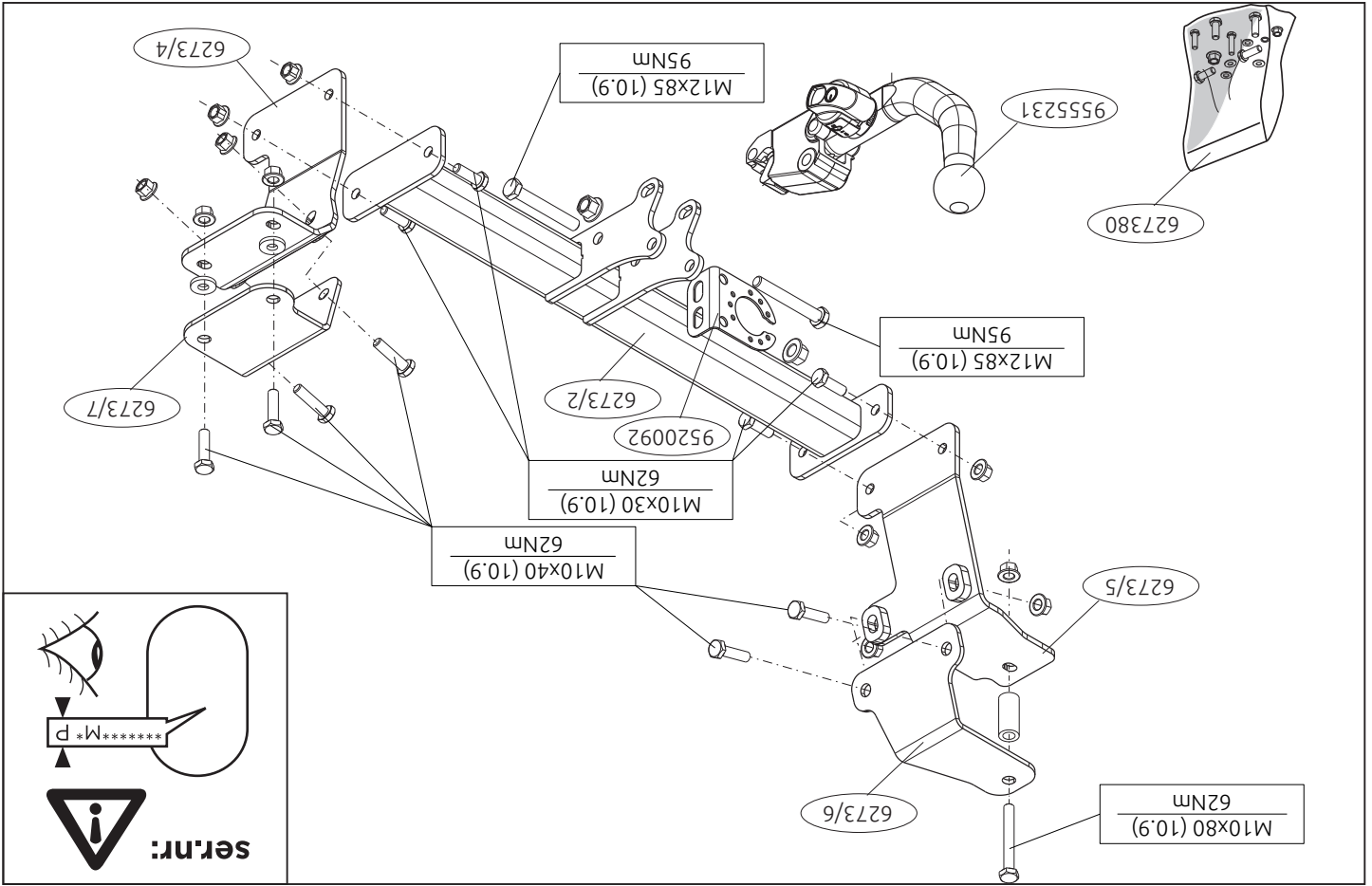

**DA COMPILARE PER IL COLLAUDO**

**Per verificare l'idoneità del dispositivo di traino omologato a norma UNECE R55, all'installazione sulla vettura su cui si intende farlo declassare la massa rimorchiabile):**

$$D = \frac{T + C}{T \times C} \times 0,00981 \leq 5,6\text{KN}$$

dove: T = Massa Complessiva Max. della motrice (in kg)  
C = Massa Rimorchiabile Max. della motrice (in kg)

Classificazione del veicolo: A50-X  
Omologazione: E11 55R 0111083  
Valore D: 5,6kN  
Carico Verticale max. S: 50 kg  
Larghezza rimorchiabile per Caravan e T.A.T.S.: 2,45m vedere CARTA di CIRCOLAZIONE VEICOLO (motrice) + 70 cm = ..arrotondare ai 5 cm  
Massa rimorchiabile: vedi carta di circolazione dell' autoveicolo

Per autoveicoli: 6273 Suzuki • Ignis 2wd 10/2016->

Tipo funzionale: MF

Classificazione e tipo di attacco: A50-X  
Omologazione: E11 55R 0111083  
Valore D: 5,6kN  
Carico Verticale max. S: 50 kg  
Larghezza rimorchiabile per Caravan e T.A.T.S.: 2,45m vedere CARTA di CIRCOLAZIONE VEICOLO (motrice) + 70 cm = ..arrotondare ai 5 cm  
Massa rimorchiabile: vedi carta di circolazione dell' autoveicolo

Il dispositivo di attacco sopra indicato è stato installato su autoveicolo

tipo: .....

modello: .....

larga: .....

Data: .....

Si dichiara inoltre di aver informato l'utente del veicolo sull'USO e MANUTENZIONE del dispositivo stesso.

**DICHIARAZIONE DI CORRETTO MONTAGGIO:** la sottoscritta Ditta dichiara di aver montato in maniera corretta ed in conformità alle prescrizioni sia del costruttore del veicolo che del costruttore del dispositivo stesso il seguente dispositivo di attacco meccanico:

**TIMBRO e FIRMA**

Dispositivo di traino tipo: 6273 Suzuki • Ignis 2wd 10/2016->

Tipo funzionale: MF

Classificazione e tipo di attacco: A50-X

Omologazione: E11 55R 0111083







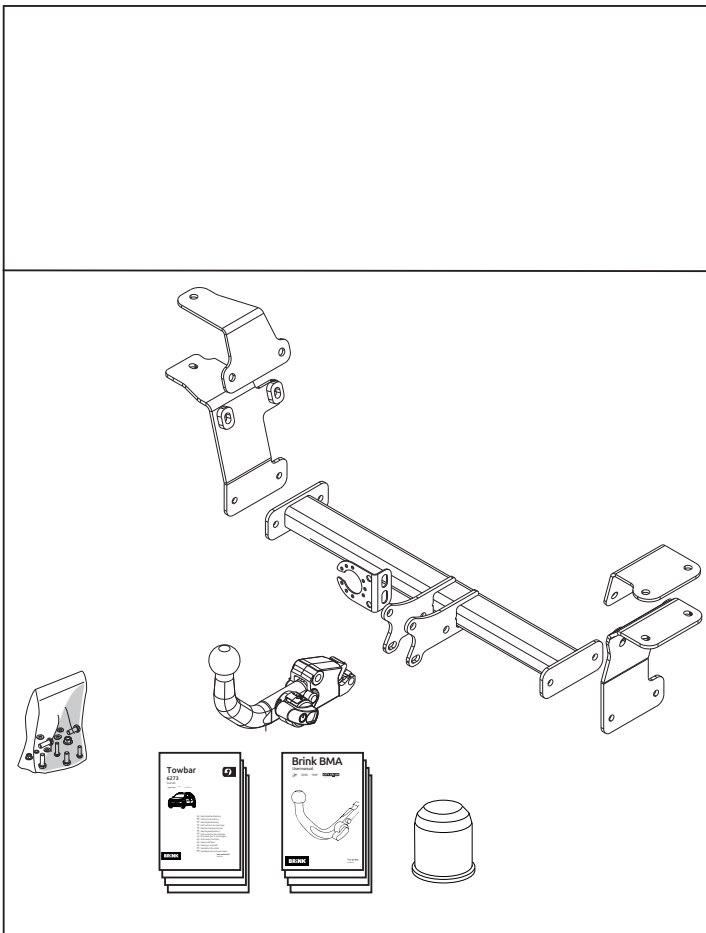

Valore D: 5,6kN

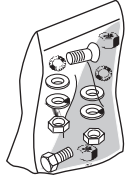
Carico Verticale max. S: 50 kg

Larghezza rimorchiabile per Caravan e T.A.T.S.: 2,45m vedere CARTA di CIRCOLAZIONE VEICOLO (motrice) + 70 cm = ..arrotondare ai 5 cm

Massa rimorchiabile: vedi carta di circolazione dell' autoveicolo



- 
-  (6x) M10x40 (10.9)
  (11x) M10
  -  (4x) M10x30 (10.9)
  (2x) M12
  (2x) M10
  -  (1x) M10x80 (10.9)
  (1x)  $\varnothing 20 \times 4$  L=44,7mm
  -  (2x) M12x85 (10.9)

© 627370/10-08-2017/4

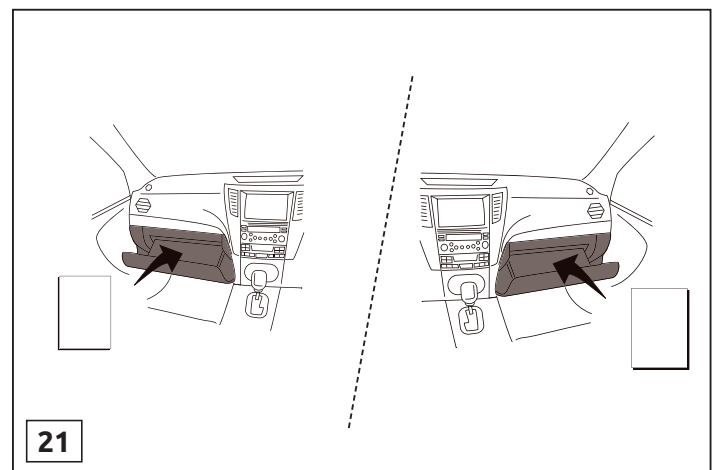
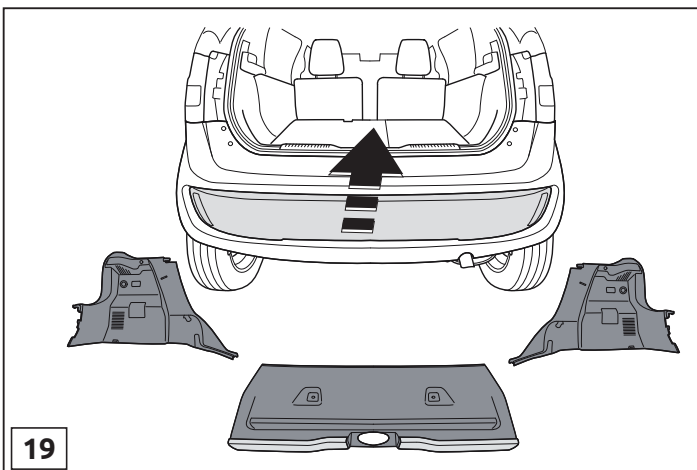
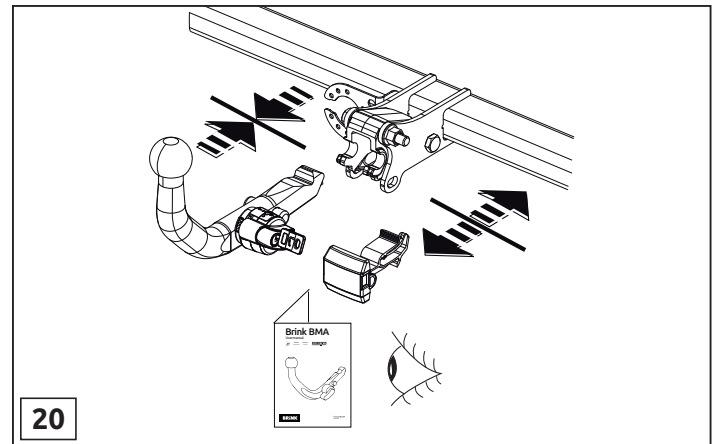
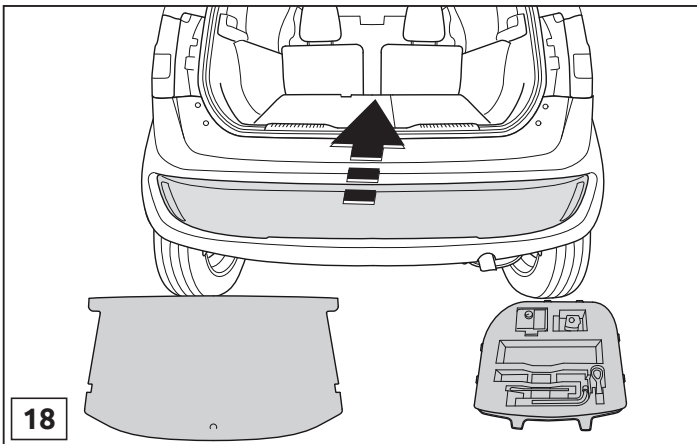

© 627370/10-08-2017/17



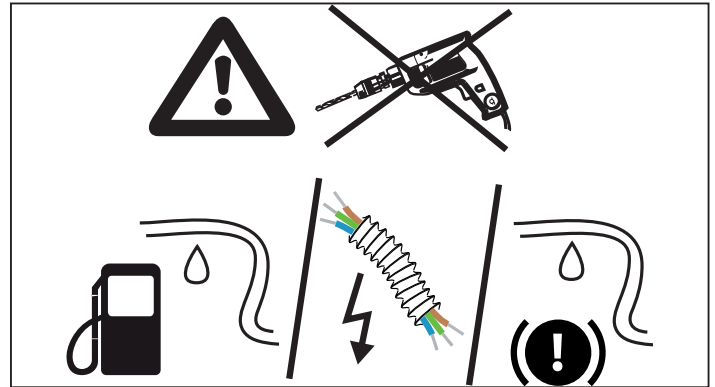
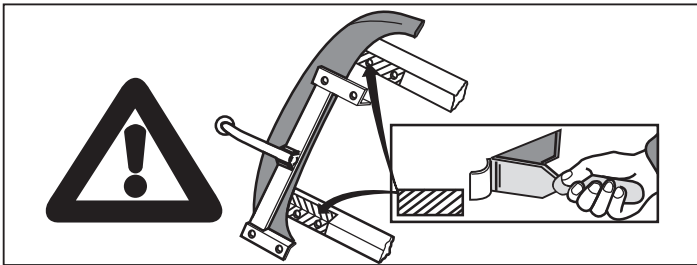
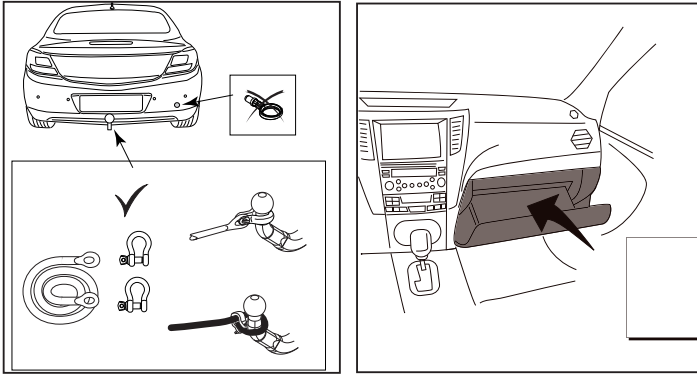
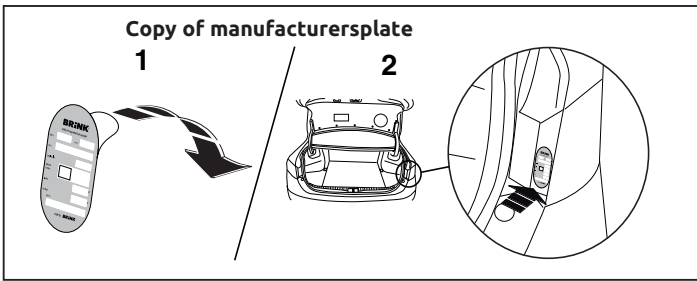

© 627370/10-08-2017/6

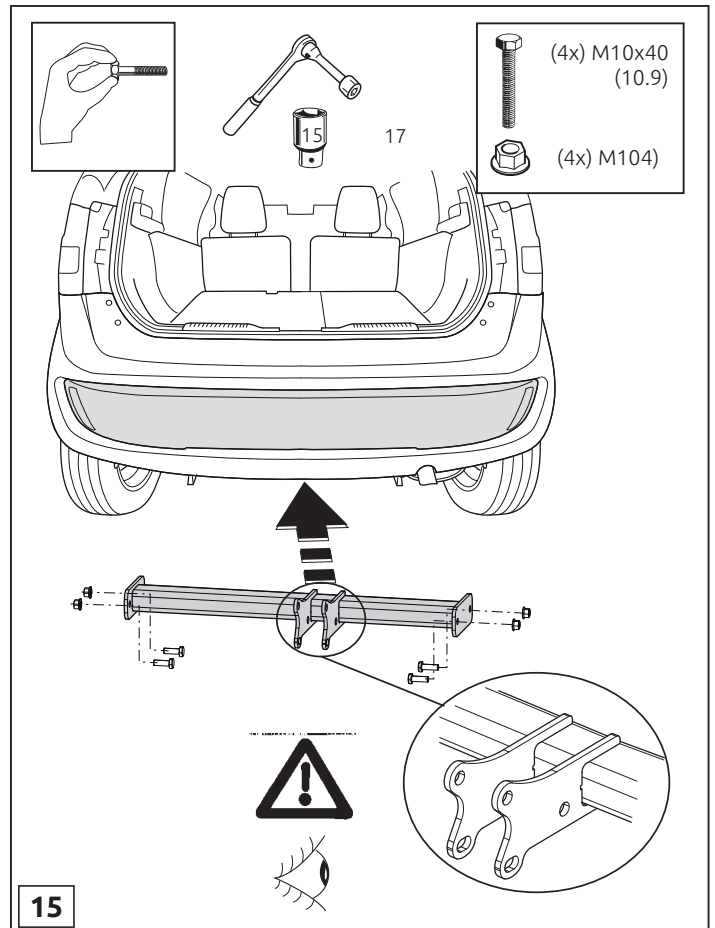
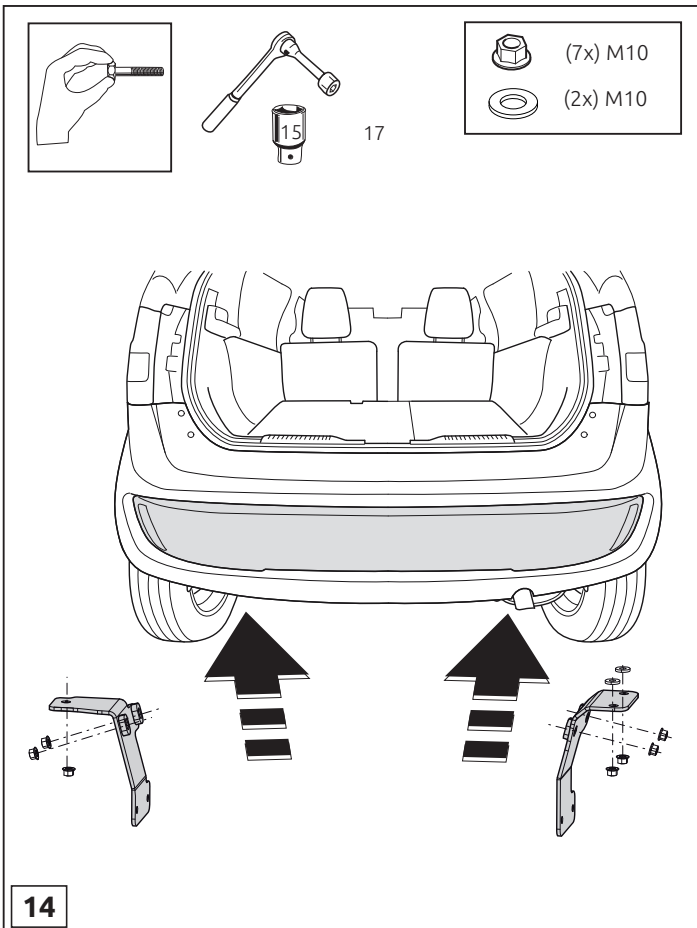

© 627370/10-08-2017/15

\* Brink Towing Systems B.V. no se responsabiliza por daños causados, directa o indirectamente, por un montaje incorrecto, incluyendo el uso de herramientas inadecuadas, por el uso de métodos de montaje y medios distintos a los indicados y por la interpretación incorrecta de estas instrucciones de montaje.

\* Brink Towing Systems B.V. er ikke ansvarlig for skade der direkte eller indirekte er forårsaget af forkert montage, herunder også iberegnet brug af forkert værktøj og anvendelse af anden montage metode og andre montage midler end de foreskrevne samt fejltilkniing af den medfølgende montagevejledning.

\* Brink Towing Systems B.V. är inte ansvariga för skada som orsakats direkt eller indirekt av felaktig montering, inklusive användning av olämpliga verktyg, andra monteringsmetoder och processer än de som beskrivs, samt felaktig tillkniing av dessa monteringsinstruktioner.

\* Brink Towing Systems B.V. décline toute responsabilité pour les dommages qui pourraient directement ou indirectement résulter d'un montage incorrect, y compris l'utilisation d'outils inappropriés et l'utilisation d'un mode d'emploi et de moyens autres que ceux prescrits, ou bien résulter d'une interprétation inexacte des présentes instructions de montage.

sowie eine fehlerhafte Interpretation der betreffenden Montageanweisung.

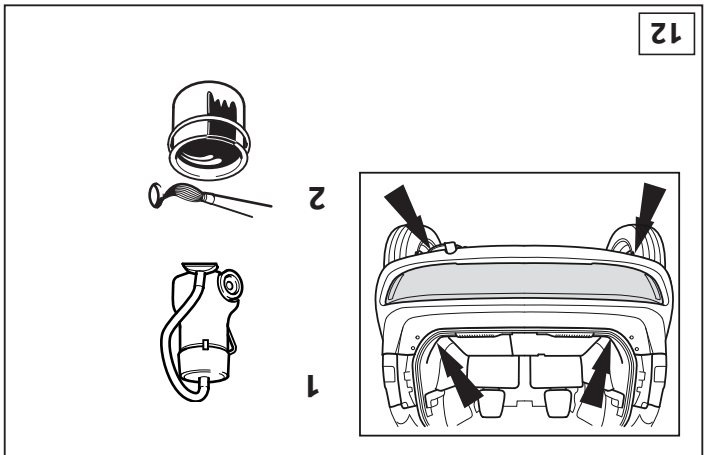
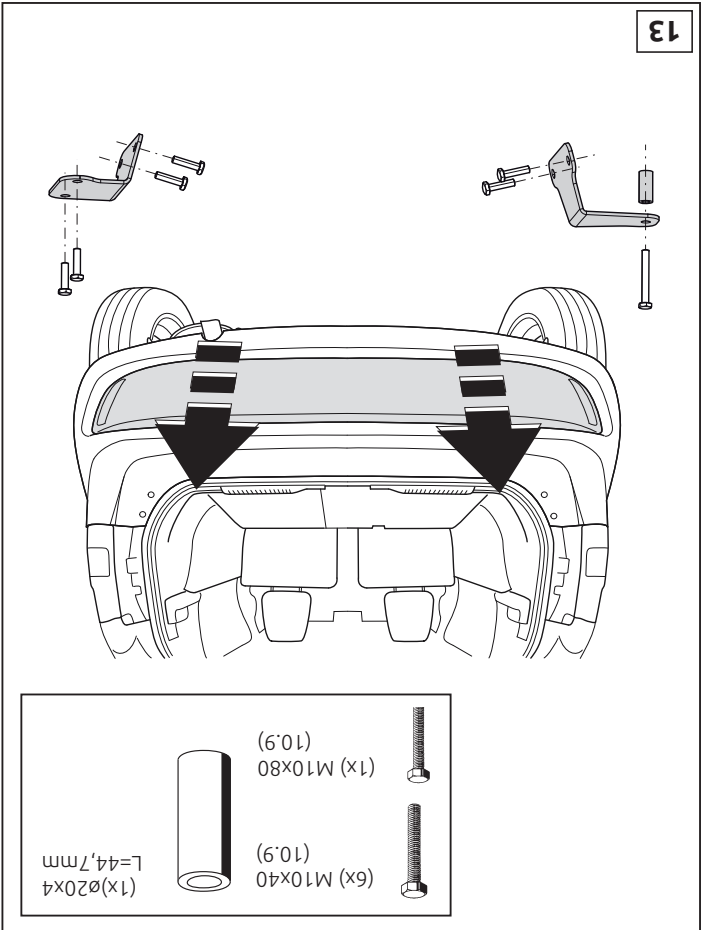

NL \* Brink Towing Systems B.V. is niet aansprakelijk voor de schade die het direct of indirect gevolg is van onjuiste montage, daaronder begrepen gebruik van niet-geschiedte gereedschappen en het gebruik van andere dan de voorgeschreven montagewijze en middele, dan wel onjuiste interpretatie van dit onderhavig montagevoorschrift.

NOTE: CB

\* Should this installation process entail the cutting of the bumper – conformation MUST be obtained by the installation engineer of the customer's acceptance prior to completion. Brink Towing Systems B.V. do not accept responsibility for any matters arising as a result of this miscommunication.

All measurements are in mm!

\* Brink Towing Systems B.V. is not liable for damage caused directly or indirectly by incorrect assembly, including the use of unsuitable tools, the use of other assembly methods and means than the ones outlined, and the incorrect interpretation of these assembly instructions.

HINWEISE: D

\* Die für das Fahrzeug zugelassene Anhängelast ist den Fahrzeug Unterlagen zu entnehmen. Bei Änderungen des Fahrzeuggewichtes muß die höchstzulässige Anhängelast gegebenenfalls aus dem D-Wert nachgerechnet werden. Auskunft hierüber kann Ihr Fachhändler oder der TÜV geben.

\* Elektrische Anlage gemäß StVZO anbringen. \* Brink Towing Systems B.V. haftet nicht für Schäden, die als direkte oder indirekte Folge einer nicht ordnungsgemäßen Montage auftreten, darunter fallen auch die Benutzung von ungeeigneten Werkzeugen, andere als die vorgeschriebenen Montageverfahren und Montagemittel

I

\* Brink Towing Systems B.V. non può essere ritenuta responsabile per eventuali danni direttamente o indirettamente dovuti ad un errato montaggio, intendendo con ciò anche l'uso di attrezzi non idonei e l'uso di metodi e mezzi di montaggio diversi da quelli prescritti, nonché all'errata interpretazione delle seguenti istruzioni di montaggio.

PL

\* Brink Towing Systems B.V. nie ponosi odpowiedzialności za straty poniesione pośrednio lub bezpośrednio na skutek niewłaściwego montażu, w tym użycia niewłaściwych narzędzi i sposobów montażu niezgodnych z instrukcją, oraz niezastosowanie się do treści instrukcji.

SF

\* Brink Towing Systems B.V. ei ole vastuussa vioittumisesta, joka on suoraan tai epäsuoraan aiheutunut väärästä asennuksesta samoin kuin sopimattomien työkalujen käytöstä, muiden kuin ohjeissa mainittujen asennusmenetelmien tai välineiden käytöstä sekä kyseisten asennusohjeiden väärintulkinnasta.

CZ

\* Společnost Brink Towing Systems B.V. neodpovídá za přímé ani nepřímé škody způsobené nesprávnou montáží, včetně použití nevhodných nástrojů, použití jiných metod montáže a prostředků než uvedených a nesprávným pochopením těchto pokynů k montáži.

H

\* A Brink Towing Systems B.V. nem vállal felelősséget a nem megfelelő szerelésből közvetlen vagy közvetett módon következő károkért. Ez vonatkozik a nem megfelelő szerszámok használatára, a leírtaktól eltérő módszerek és eszközök alkalmazására, valamint a szerelési útmutató

téves értelmezésére.

RUS

\* Фирма Brink Towing Systems B.V. не отвечает за ущерб, являющийся прямым или косвенным следствием неправильного монтажа, в том числе использования неподходящих инструментов и применения иного способа монтажа или других средств, чем предписано в инструкции, либо неправильного истолкования настоящей инструкции по монтажу.

© 627370/10-08-2017/8

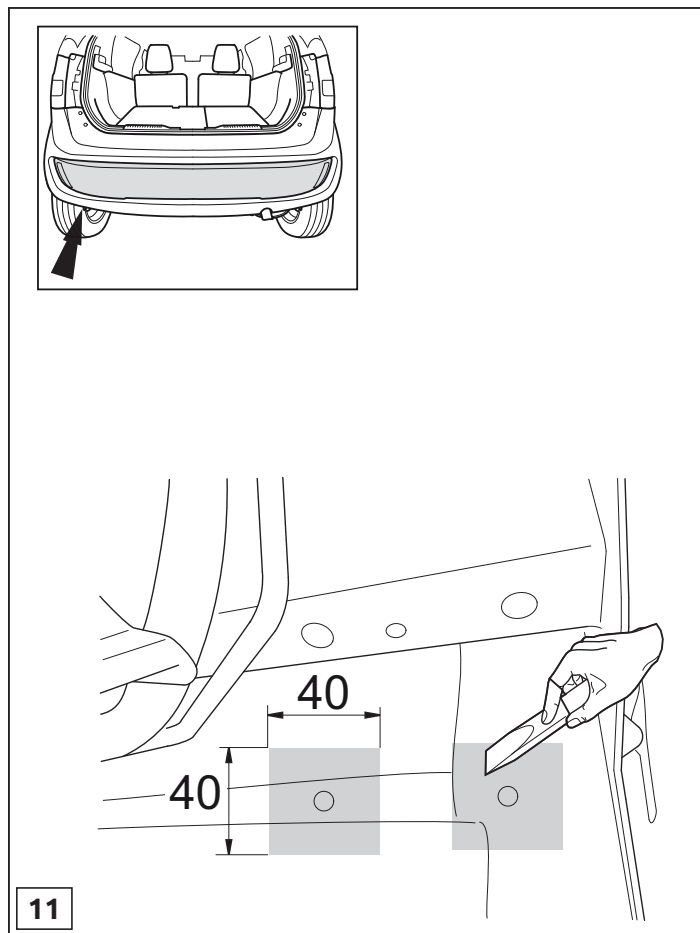
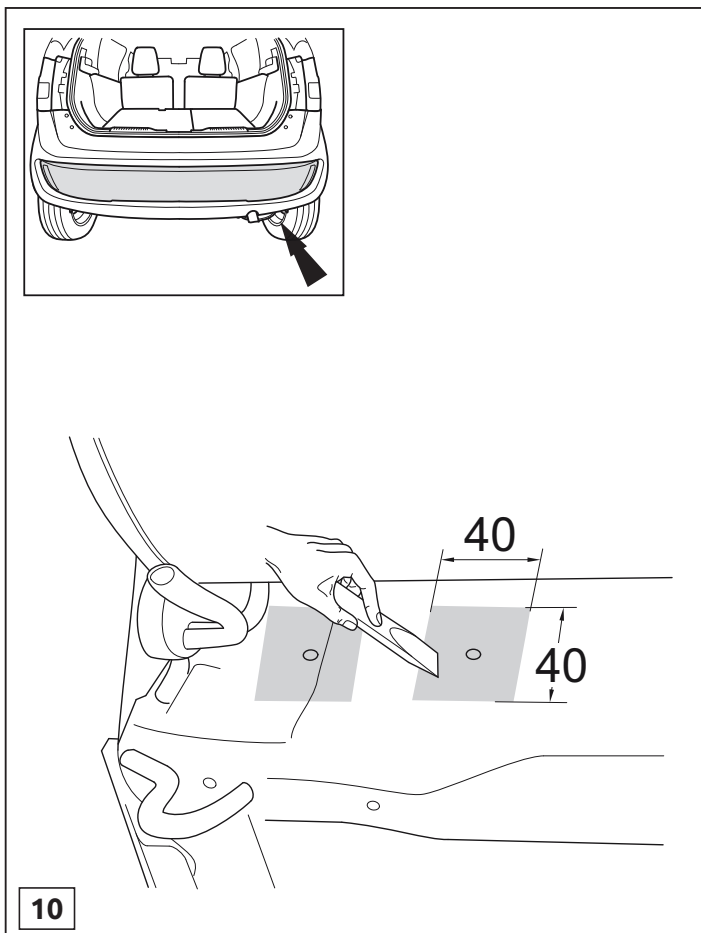

© 627370/10-08-2017/13



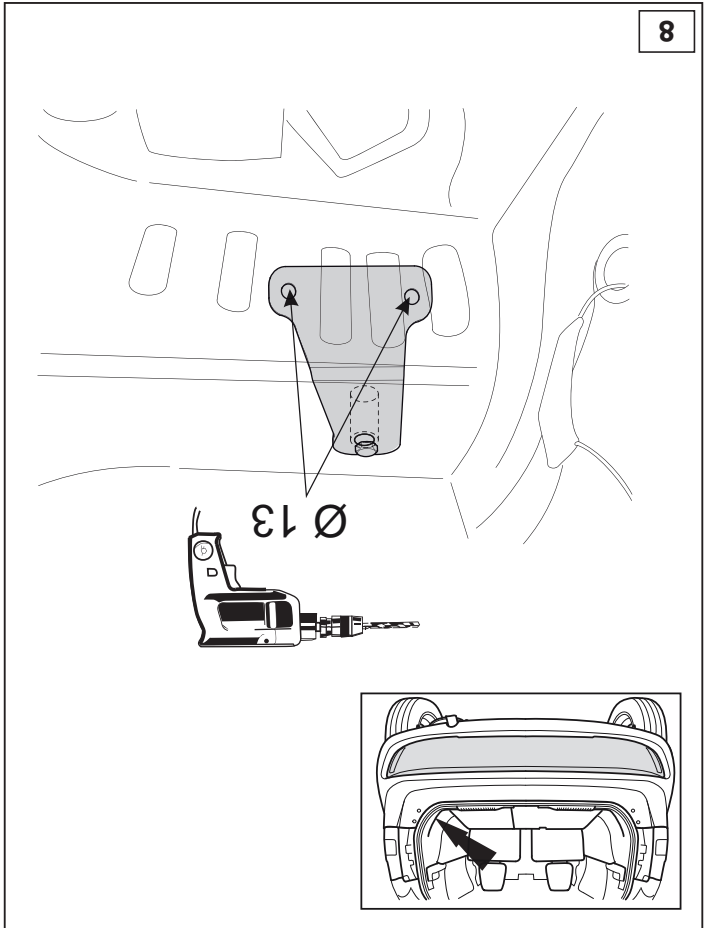
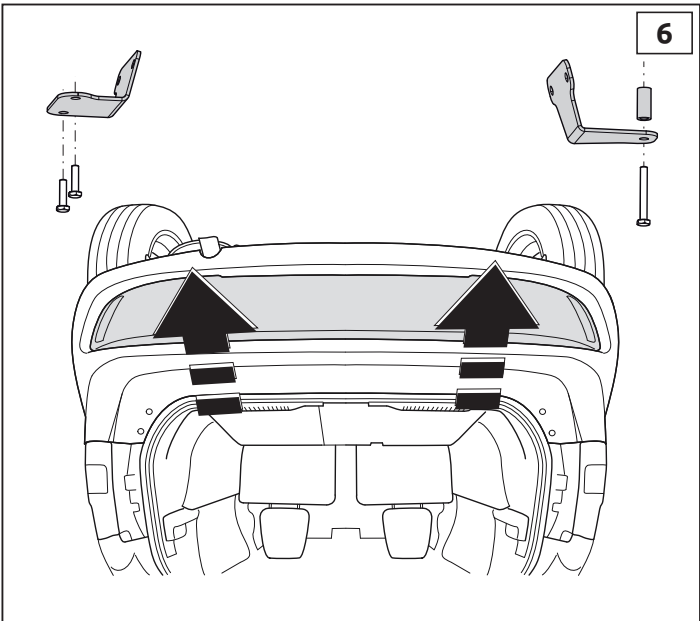
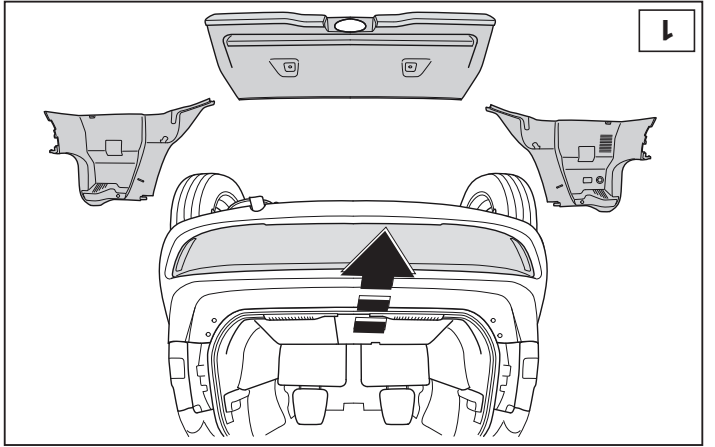
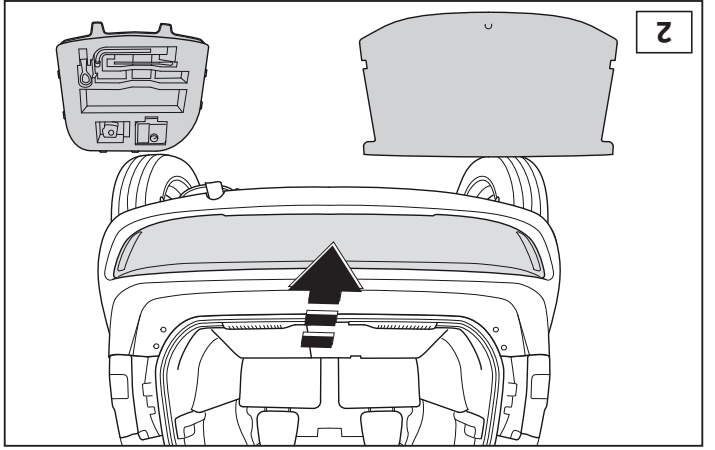
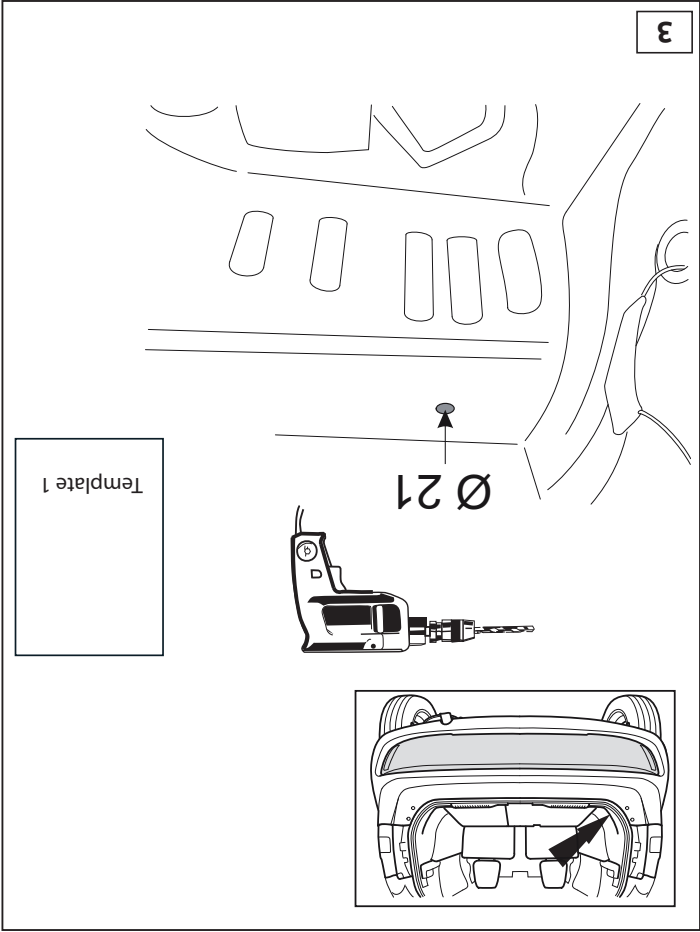

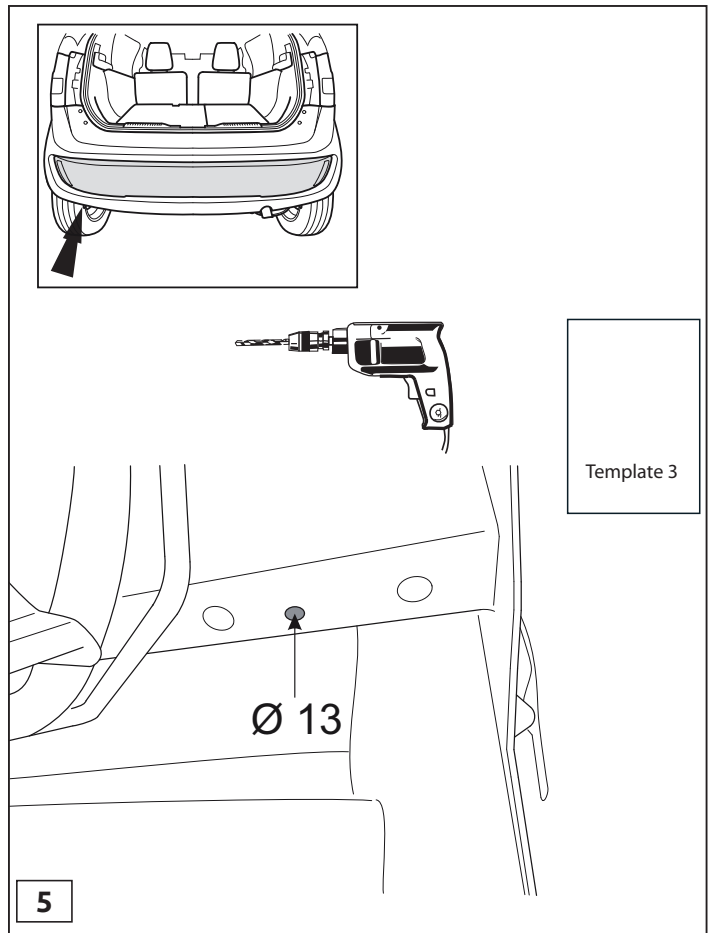
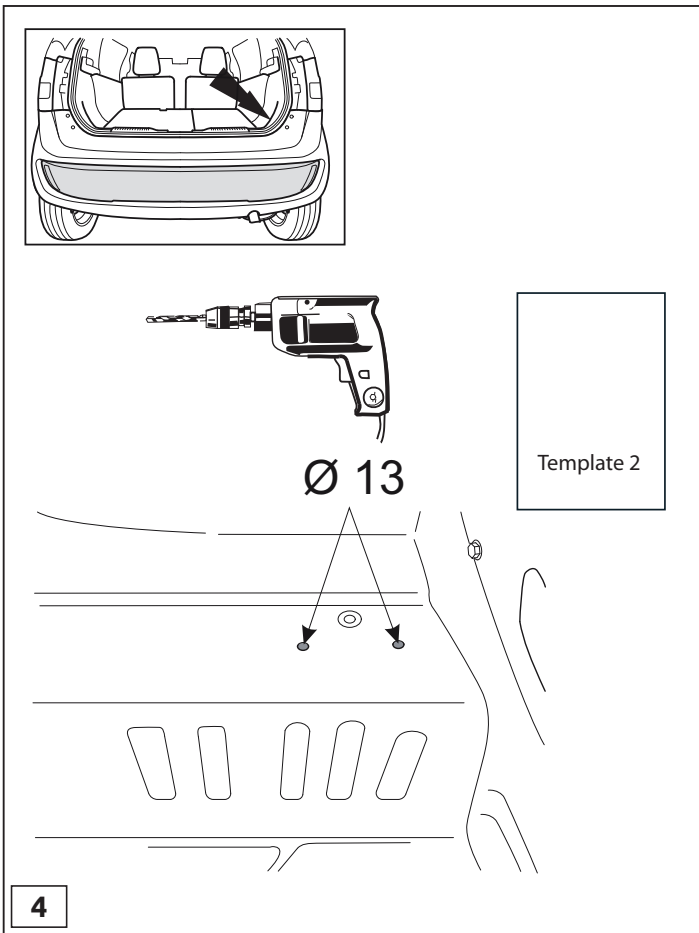

© 627370/10-08-2017/10

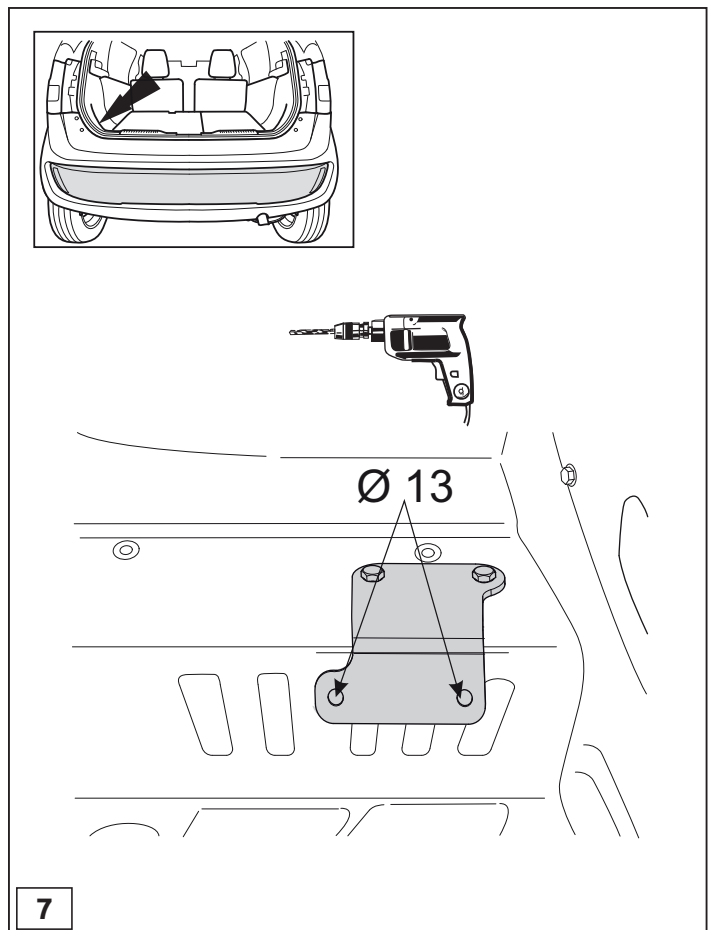
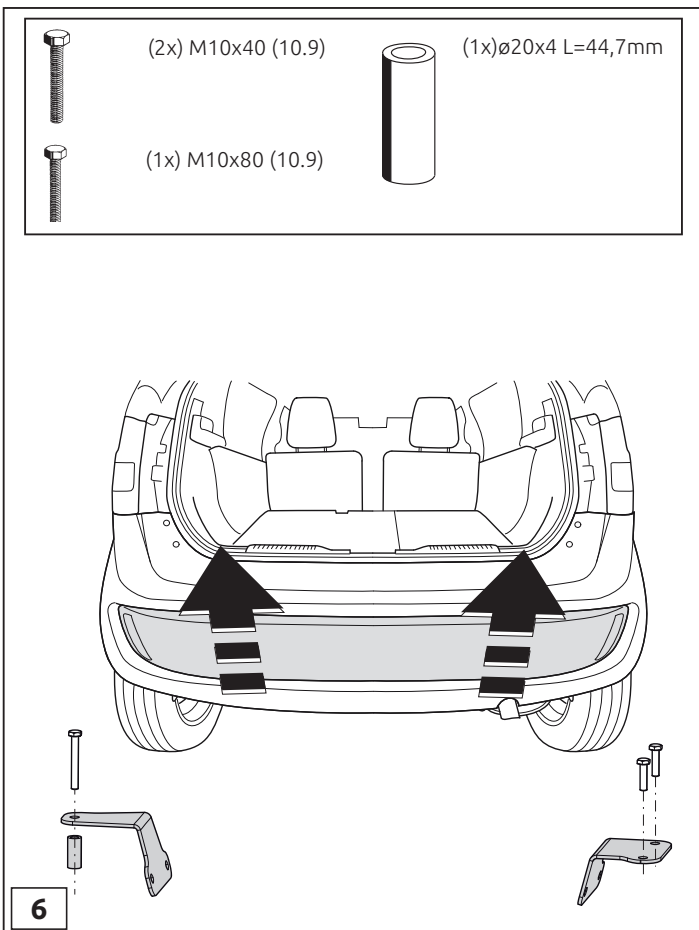

© 627370/10-08-2017/11



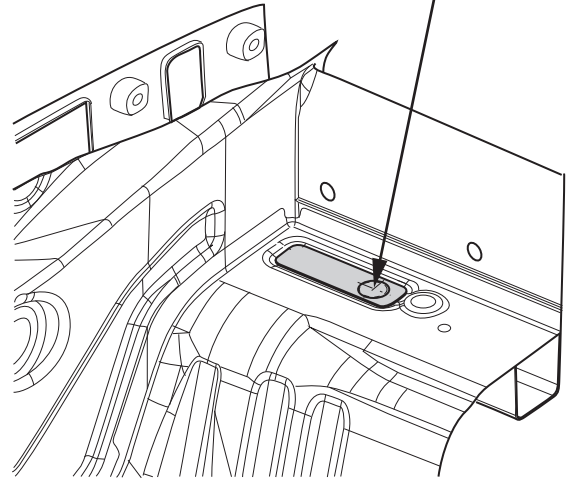
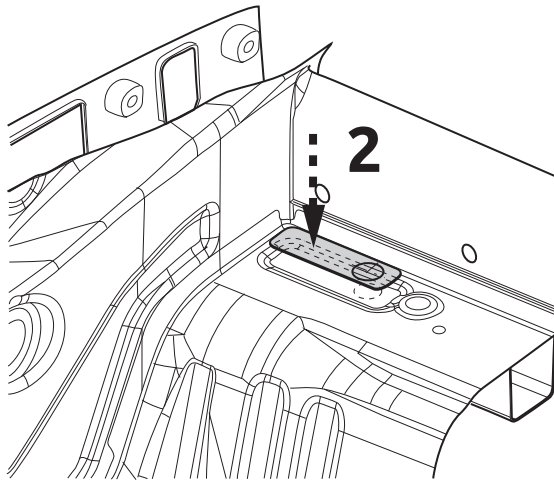
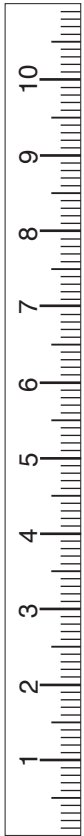
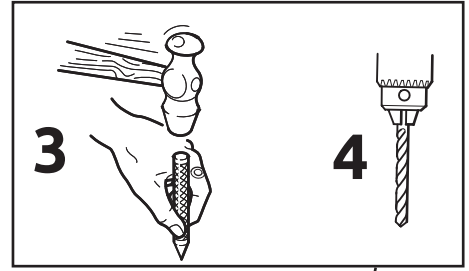
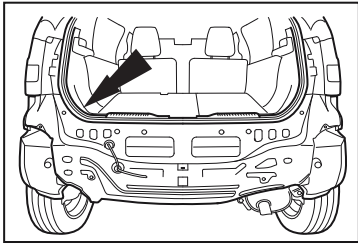

**1:1**

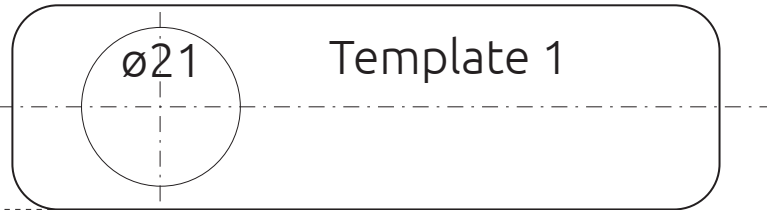
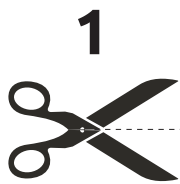



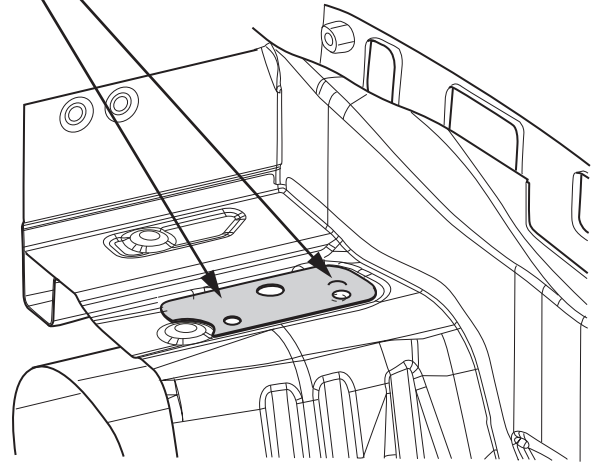
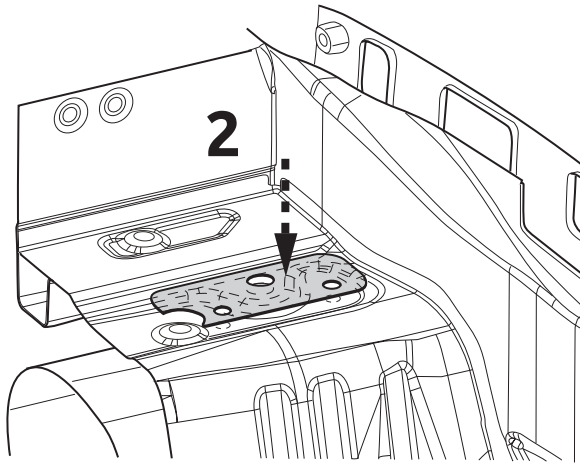
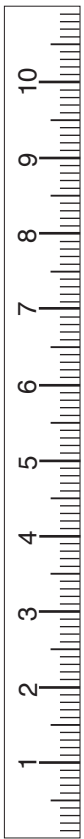
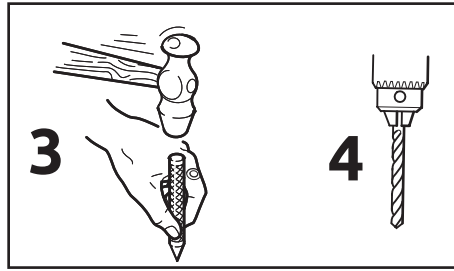
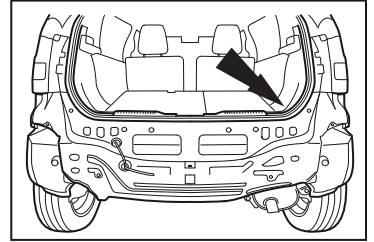

**1:1**

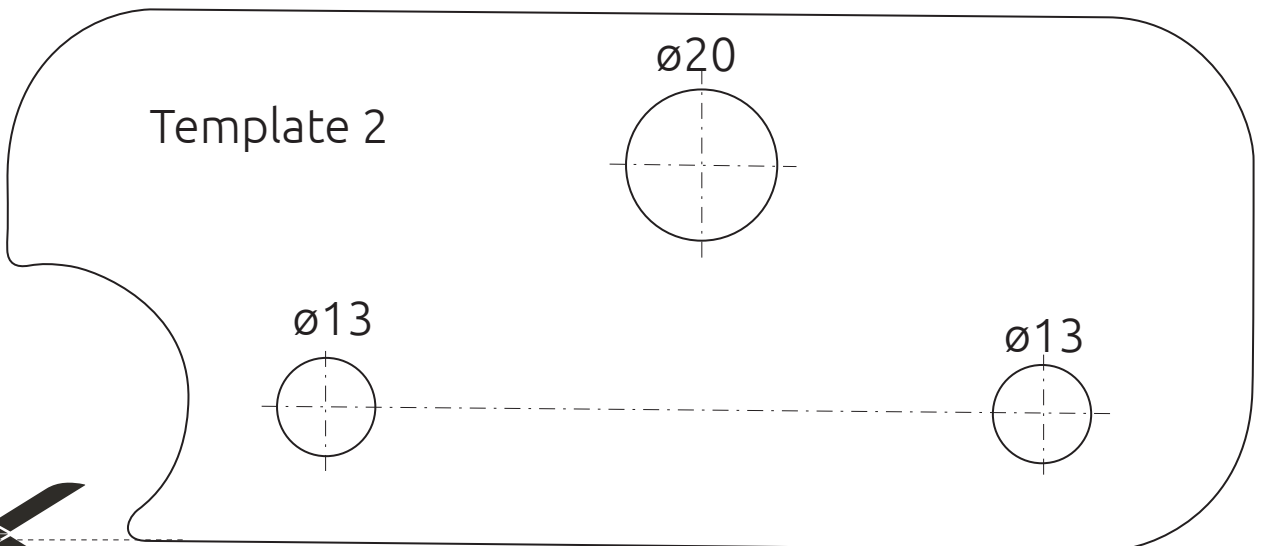



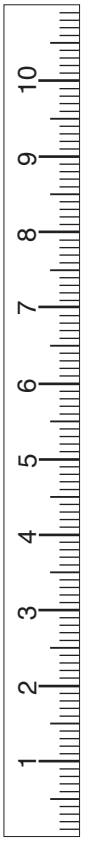
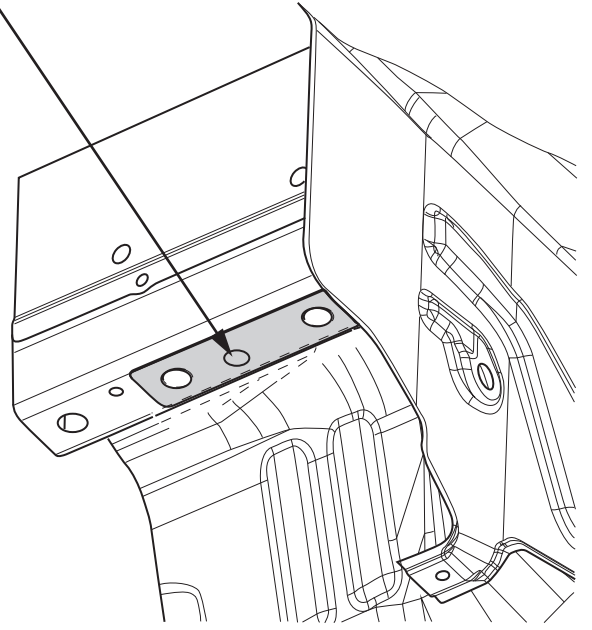
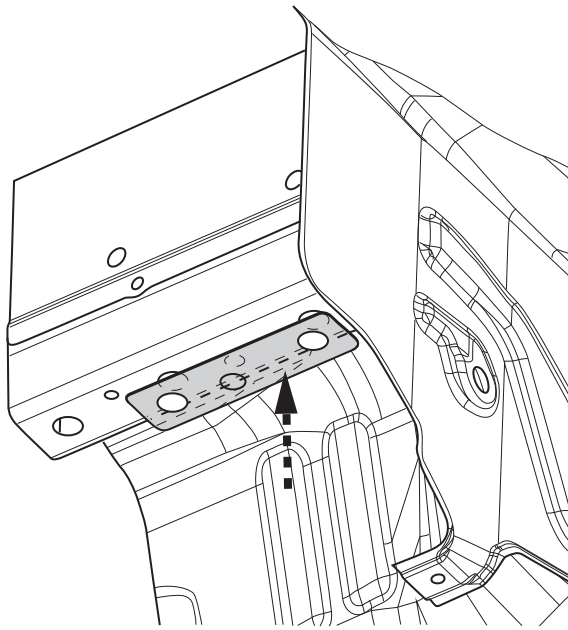
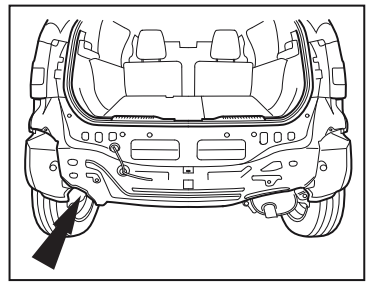
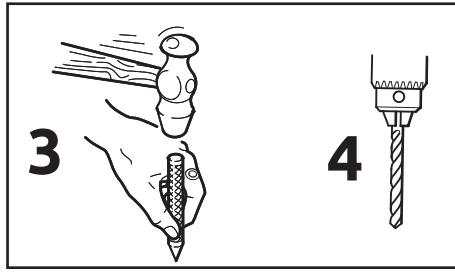

1:1

Template 3

