

FITTING INSTRUCTION

Clamp mark in acc. with		Cables joining
ISO	PN	
1	L	Left directional lights
2	+	Rear fog lights
3	31	Ground
4	R	Right directional lights
5	58R	Right side parking lights
6	54	Stoptlights
7	58L	Left side parking lights

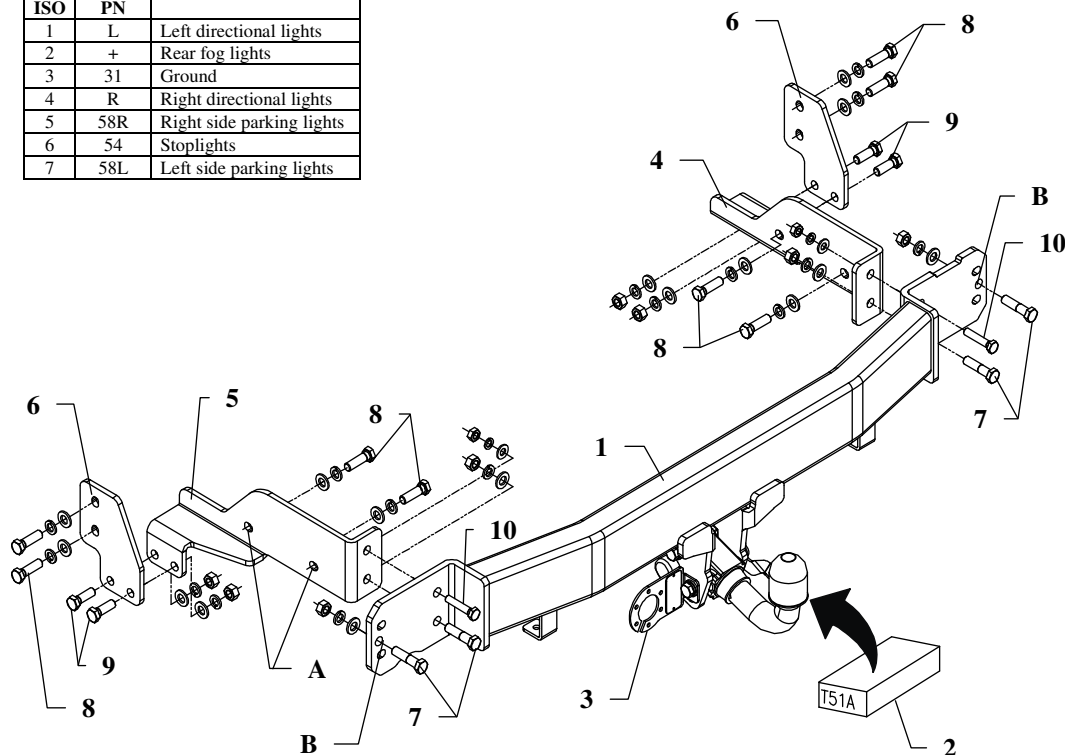

This towing hitch is designed to assembly in following cars:
KIA SORENTO (JC), produced since 07.2006 till 10.2009, catalogue no.
T51A and is prepared to tow trailers max total weight **3500 kg** and max vertical load **140 kg**.

From manufacturer

Thank you for buying our product. Their reliability has been confirmed in many tests. Reliability of towing hitch depends also on correct assembly and right operation. For this reasons we kindly ask to read carefully this instruction and apply to hints.

The towing hitch should be install in points described by a car producer.

The instruction of the assembly

1. Take out the spare wheel.
2. Disassemble the bumper.
3. Disassemble transverse reinforcement (will not be assembled again).
4. Apply right bracket (pos. 4) and left (pos. 5) to frame of the car in that way so holes A be covered with threaded holes in the frame and fix loosely using bolts M12x1.5x40mm (pos. 8).
5. Fix side brackets (pos. 6) to frame of the car using bolts M12x4.5x40mm (pos. 8) and then fix them to right bracket (pos. 4) and left bracket (pos. 5) using bolts M12x35mm (pos. 9), see drawing 1.
6. On protruding pins in rear slice apply the main bar of the towing hitch (pos. 1) and fix using bolts M10x50mm (pos. 10) and M12x50mm (pos. 7) together with brackets (pos. 4 and 5).
7. Through holes B of the towing hitch drill holes $\varnothing 12.5\text{mm}$ and fix using bolts M12x50mm (pos. 7), see drawing 1.
8. Tighten all bolts according to the torque shown in the table.
9. Install the bumper after cut out of its fragment, see drawing 2.

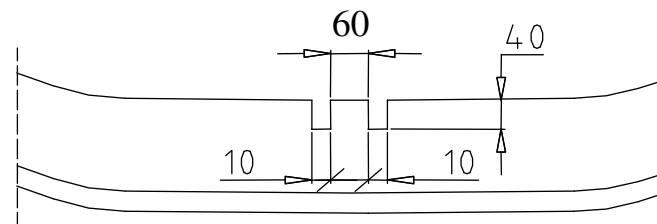

Fig. 2

10. Fix body of the automat and place tow-ball according to supplied instruction. Note! Remember to place socket plate (pos. 3) as shown on the drawing 1.
11. Connect electric wires of 7-poles socket according to the instruction of the car. (Recommend to make at authorized service station).
12. Complete paint layer damaged during installation.

Torque settings for nuts and bolts (8,8):	
M 8 - 25 Nm	M 10 - 55 Nm
M 12 - 85 Nm	M 14 - 135 Nm











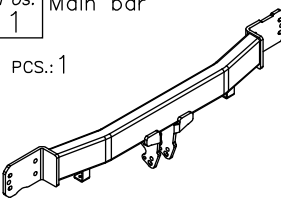
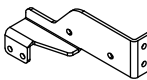

NOTE

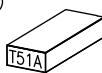
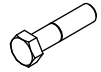
After install the towing hitch you should get adequate note in registration book (at authorised service station). The car should be equipped with:

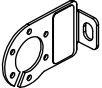
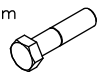
- Indicators
- Tow mirrors

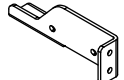
After 1000km of exploitation check all bolts and nuts. The ball of towing hitch must be always kept clear and conserve with a grease.

Towing hitch accessories:

Pos. 1 Main bar PCS.: 1 	Pos. 5 Left bracket PCS.: 1 	Pos. 11 Nut 8 B M12 PCS.: 8 
	Pos. 6 Side bracket PCS.: 2 	Pos. 12 Nut 8 B M10 PCS.: 2 
Pos. 2 Tow ball (mounting set) PCS.: 1 	Pos. 7 Bolt 8,8 B M12x50mm PCS.: 4 	Pos. 13 Plain washer ø12mm PCS.: 16 
Pos. 3 Socket plate PCS.: 1 	Pos. 8 Bolt 8,8 B M12x1.5x40mm PCS.: 8 	Pos. 14 Plain washer ø10mm PCS.: 2 
Pos. 4 Right bracket PCS.: 1 	Pos. 9 Bolt 8,8 B M12x35mm PCS.: 4 	Pos. 15 Spring washer ø12mm PCS.: 16 
	Pos. 10 Bolt 8,8 B M10x50mm PCS.: 2 	Pos. 16 Spring washer ø10mm PCS.: 2 



PPUH AUTO-HAK S.J.

Produkcja Zaczepów Kulowych
Henryk & Zbigniew Nejman
76-200 SŁUPSK ul. Słoneczna 16K
tel/fax (059) 8-414-414; 8-414-413
E-mail: office@autohak.com.pl
www.autohak.com.pl

Towing hitch (without electrical set)

Class: **A50-X** Cat. no. **T51A**

Designed for:

Manufacturer: **KIA**

Model: **SORENTO (JC)**

produced since 07.2006 till 10.2009

Technical data:

D-value: 14,9 kN

maximum trailer weight: **3500 kg**

maximum vertical cup load: **140 kg**

Approval number according to Directive 94/20/EC: e20*94/20*1024*00

Foreword

This towing hitch is designed according to rules of safety traffic regulations. The towing hitch is a safety component and can be install only by qualified personnel. Any alteration or conversion of the towing hitch is prohibited and would lead to cancellation of design certification. Remove insulating compound and underseal from vehicle (if present) in the area of the matting surfaces of the towing hitch.

The vehicle manufacturer's specifications regarding trailer load and max. vertical cup load are decisive for driving whereat values for the towing hitch cannot be exceeded.

D-value formula:

$$\frac{\text{Max trailer weight [kg]} \times \text{Max vehicle weight [kg]}}{\text{Max trailer weight [kg]} + \text{Max vehicle weight [kg]}} \times \frac{9,81}{1000} = D \text{ [kN]}$$