

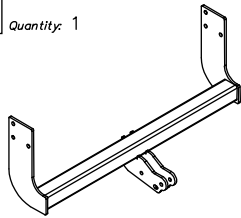



## Towbar accessories:

Pos. 1	Name: Main bar Quantity: 1	Pos. 4	Name: Fish-plate Quantity: 2	Pos. 8	Name: Nut 8 B Quantity: 8 Dim. : M12
		Pos. 5	Name: Distance sleeve Quantity: 6 Dim. : $\varnothing 22 \times 2,35 \text{mm}$ L=45mm	Pos. 9	Name: Plain washer Quantity: 8 Dim. : $\varnothing 13 \text{ mm}$
Pos. 2	Name: Tow-ball Quantity: 1	Pos. 6	Name: Bolt 8,8 B Quantity: 6 Dim. : M12x90mm	Pos. 10	Name: Spring washer Quantity: 8 Dim. : $\varnothing 12,2 \text{ mm}$
		Pos. 3	Name: Bolt 8,8 B Quantity: 2 Dim. : M12x75mm	Pos. 11	Name: Ball cover Quantity: 1
Pos. 3	Name: Socket plate Quantity: 1				
					

Torque settings for nuts and bolts (8,8):

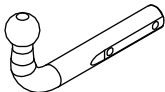
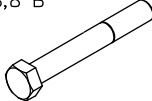
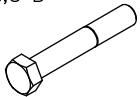
**M 8** - 25 Nm      **M 10** - 55 Nm  
**M 12** - 85 Nm      **M 14** - 135 Nm

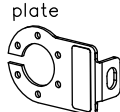

**PPUH AUTO-HAK Sp.J.**

Produkcja Zaczepów Kulowych  
 Henryk & Zbigniew Nejman  
 76-200 SŁUPSK ul. Słoneczna 16K  
 tel/fax (059) 8-414-414; 8-414-413  
 E-mail: [office@autohak.com.pl](mailto:office@autohak.com.pl)  
[www.autohak.com.pl](http://www.autohak.com.pl)

## Towing hitch (without electrical set)

Class: **A50-X**    Cat. no. **T23**

Designed for:

Manufacturer: **KIA**

Model: **K2700 / FRONTIERS**

Type: **loading platform**

produced since 1998r.

Technical data:

**D-value: 9,7 kN**

maximum trailer weight: **1400 kg**

maximum vertical cup load: **75 kg**

Approval number acc. to regulation EKG/ONZ 55.01: **E20-55R-01 1564**

### Foreword

This towing hitch is designed according to rules of safety traffic regulations. The towing hitch is a safety component and can be install only by qualified personnel. Any alteration or conversion of the towing hitch is prohibited and would lead to cancellation of design certification. Remove insulating compound and underseal from vehicle (if present) in the area of the matting surfaces of the towing hitch. The vehicle manufacturer's specifications regarding trailer mass and max. vertical cup mass are decisive for driving whereat values for the towing hitch cannot be exceeded.

*D-value formula:*

$$\frac{\text{Max trailer weight [kg]} \times \text{Max vehicle weight [kg]}}{\text{Max trailer weight [kg]} + \text{Max vehicle weight [kg]}} \times \frac{9,81}{1000} = D \text{ [kN]}$$

## FITTING INSTRUCTION

Clamp mark in acc. with		Cables joining
ISO	PN	
1	L	Left directional lights
2	+	Rear fog lights
3	31	Ground
4	R	Right directional lights
5	58R	Right side parking lights
6	54	Stoptlights
7	58L	Left side parking lights

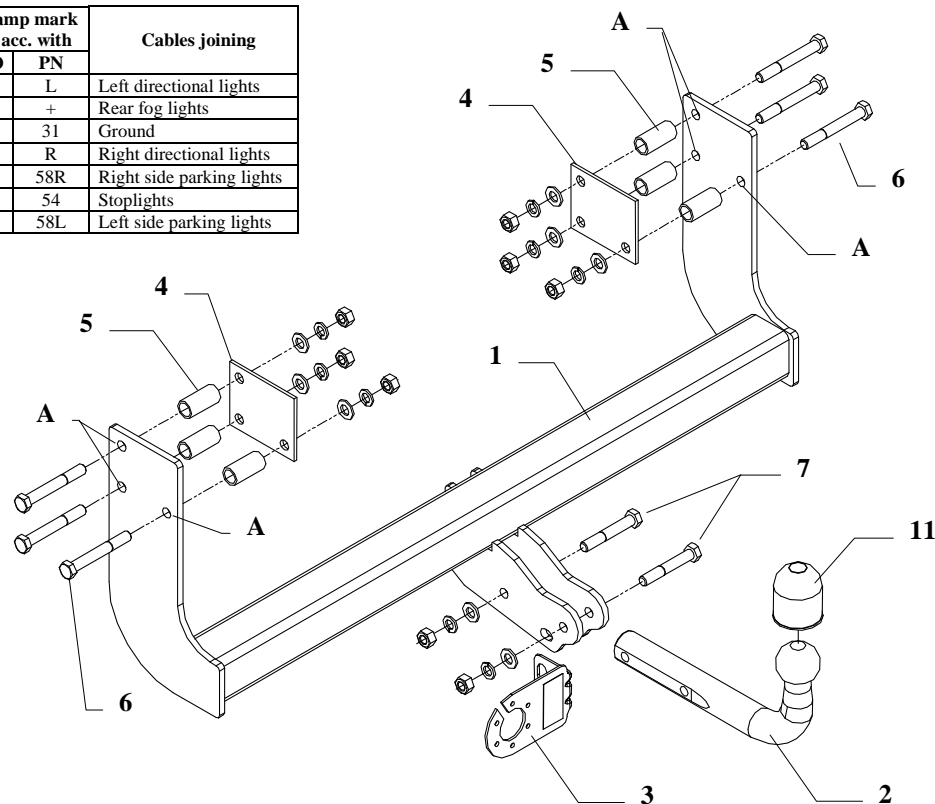

This towbar is designed to assembly in following car:

**KIA 2700 / FRONTIERS, loading platform**, produced since 1998, catalogue no. **T 23** and is prepared to tow trailers max total weight **1400kg** and max vertical load **75kg**.

### *From manufacturer*

Thank you for buying our product. Their reliability has been confirmed in many tests. Reliability of towbar depends also on correct assembly and right operation. For this reasons we kindly ask to read carefully this instruction and apply to hints.

*The towbar should be install in points described by a car producer.*

## Fitting instructions

1. The main bar of the towbar put outside of the chassis members (see fig. no. 2). Squeeze up main bar to chassis members and drill holes pos. A straight through using bit  $\varnothing 12,5\text{mm}$ .
2. Made holes drill again (only from inside) by bit  $\varnothing 22,5\text{mm}$ , put distance sleeves (pos. 5), put fish-plate (pos. 4) and twist on using bolts M12x90mm (pos. 6).

### **ATTENTION!**

At the turn of the year 2004/2005 manufacturer has change the construction. All montage points are originally prepared. You must use only bolts M12x90mm (without distance sleeves pos.5 and fish-plates pos. 4, no drill).

3. Fix tow-ball (pos. 2) and socket plate (pos. 3) by bolts M12x100mm (pos. 4) from equipment.
4. Tighten all bolts according to the torque shown in the table.
5. Connect electric wires of 7-pole socket according to the instruction of the car. (Recommend to make at authorized service station)
6. Complete paint layer damaged during installation.

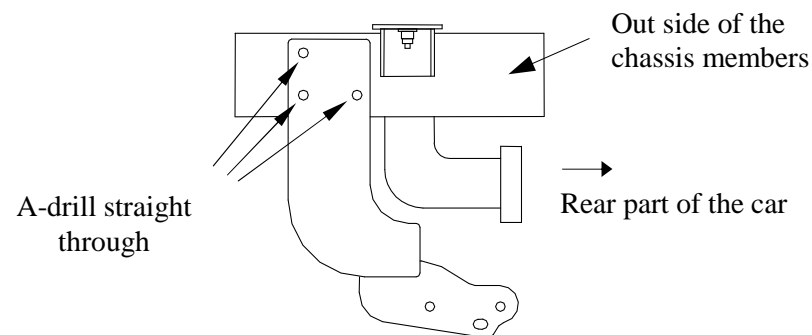

Fig. 2 Main bar installation

### **NOTE**

After install the towbar you should get adequate note in registration book (at authorised service station).The car should be equipped with:

- Indicators
- Tow mirrors

After 1000km of exploitation check all bolts and nuts. The ball of towbar must be always kept clear and conserve with a grease.