

FITTIN INSTRUCTION

Clamp mark in acc. with		Cables joining
ISO	PN	
1	L	Left directional lights
2	+	Rear fog lights
3	31	Ground
4	R	Right directional lights
5	58R	Right side parking lights
6	54	Stoplights
7	58L	Left side parking lights

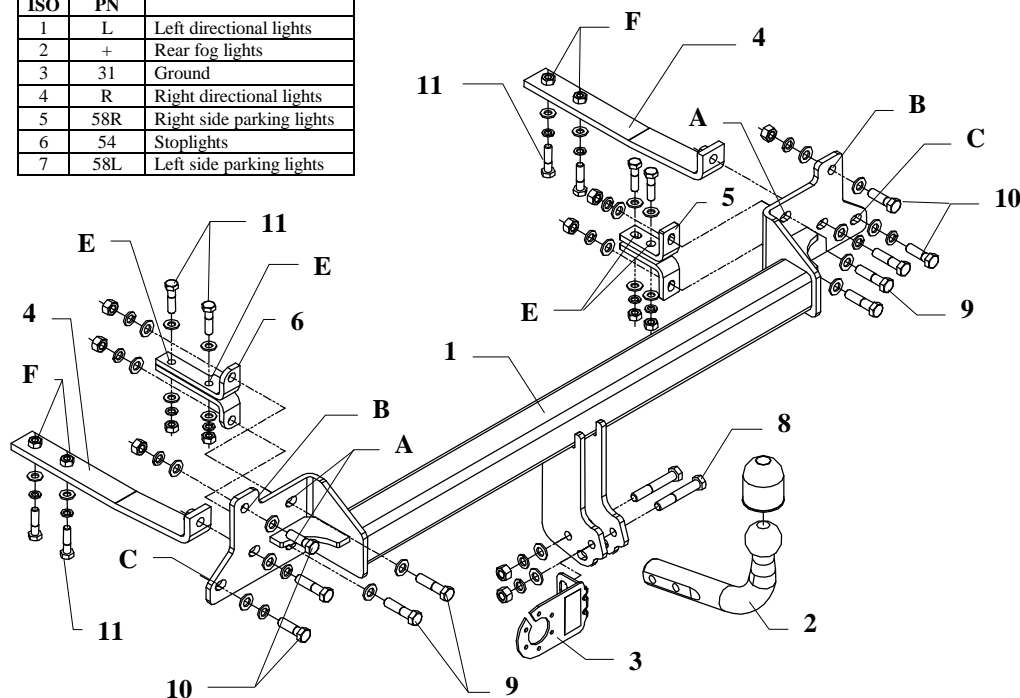

This towbar is designed to assembly in following car:

MAZDA 626 4-5 doors, produced since 07.1997 till 06.2002, catalogue number **M44** and is prepared to tow trailers max total weight **1800 kg** and max vertical load **75 kg**.

From manufacturer

Thank you for buying our product. Their reliability has been confirmed in many tests. Reliability of towbar depends also on correct assembly and right exploit. For this reasons we kindly ask to read carefully this instruction and apply to hints.

The towbar should be install in points described by a car producer.

The instruction of the assembly

1. In luggage part of car remove rack, take out carpet, remove central cover panel (nearby lock). Next disassemble and take out internal, side cover panels. Disassemble a rear bumper.
2. Make holes in rear part of car body. Use enclosed templates. They should be placed in bottom part, on either side.
3. To chassis members (through made holes) slip elements pos. **4** in that way so holes (pos. **F**) agree with original holes in chassis members. Fix with bolts M10x40mm (pos. **11**).
4. Put main bar of towbar pos. **1** to rear part of body and fix to elements pos. **4** (placed in chassis members) using bolts M12x50mm (pos. **9**).
5. In rear part of body car drill missed holes (**A, B, C**) using bit $\phi 12,5$ mm.
6. Through holes **B** and **C** fix towbar using bolts M12x30 (pos. **10**).
7. Put fish-plates pos. **5** and **6** in trunk and from below of car in that way so holes in elements agree with holes pos. **A** in towbar and fix all using bolts M12x50mm (pos. **9**).
8. Through fish-plates **5** and **6** drill holes **E** in trunk floor. Through made holes fix all using bolts M10x40mm (pos. **11**).
9. Fix tow-ball (pos. **2**) and socket plate (pos. **3**) using bolts M12x75mm (pos. **8**) from accessories.
10. Reassemble bumper after modifications. See enclosed drawings.
11. Reassemble covering elements in the trunk.
12. Fix tight all bolts according to the torque shown in the table.
13. Connect electric wires of 7-poles socket according to the instruction of the car. (Recommend to make at authorized service station)
14. Complete paint layer damaged during installation.

Torque settings for nuts and bolts (8,8):

M6 - 11 Nm	M8 - 25 Nm	M10 - 50 Nm
M12 - 87 Nm	M14 - 138 Nm	M16 - 210 Nm











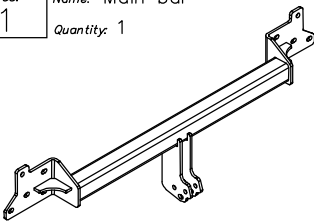
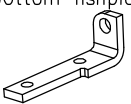

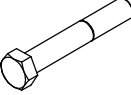

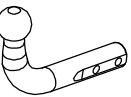
NOTE

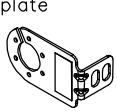
After install the towbar you should get adequate note in registration book (at authorised service station).The car should be equipped with:

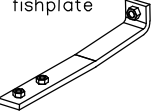
- Indicators
- Tow mirrors

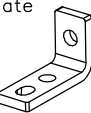
After 1000km of exploitation check all bolts and nuts. The ball of towbar must be always kept clear and conserve with a grease.

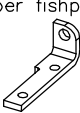
Towbar accessories:

Pos: 1	Name: Main bar Quantity: 1	Pos: 7	Name: Right, bottom fishplate Quantity: 1	Pos: 14	Name: Plain washer Quantity: 18 Dim.: \varnothing 13 mm
					
		Pos: 8	Name: Bolt 8,8 B Quantity: 2 Dim.: M12x75mm	Pos: 15	Name: Plain washer Quantity: 12 Dim.: \varnothing 10,5 mm
					
Pos: 2	Name: Tow ball Quantity: 1	Pos: 9	Name: Bolt 8,8 B Quantity: 6 Dim.: M12x50mm	Pos: 16	Name: Spring washer Quantity: 12 Dim.: \varnothing 12,2 mm
					
Pos: 3	Name: Socket plate Quantity: 1	Pos: 10	Name: Bolt 8,8 B Quantity: 4 Dim.: M12x30mm	Pos: 17	Name: Spring washer Quantity: 8 Dim.: \varnothing 10,2 mm
					
Pos: 4	Name: Angle fishplate Quantity: 2	Pos: 11	Name: Bolt 8,8 B Quantity: 8 Dim.: M10x40mm	Pos: 19	Name: Ball cover Quantity: 1
					
Pos: 5	Name: Left fishplate Quantity: 2	Pos: 12	Name: Nut 8 B Quantity: 8 Dim.: M12		
					
Pos: 6	Name: Right, upper fishplate Quantity: 1	Pos: 13	Name: Nut 8 B Quantity: 4 Dim.: M10		
					



PPUH AUTO-HAK S.J.

Produkcja Zaczepów Kulowych
Henryk & Zbigniew Nejman
76-200 SŁUPSK ul. Słoneczna 16K
tel/fax (059) 8-414-414; 8-414-413
E-mail: office@autohak.com.pl
www.autohak.com.pl

Towing hitch (without electrical set)

Class: **A50-X** Cat. no. **M44**

Designed for:

Manufacturer: **MAZDA**

Model: **626**

Type: **4-5 doors**

produced since 07.1997 till 06.2002

Technical data:

D-value: 8,89 kN

maximum trailer weight: **1800 kg**

maximum vertical cup load: **75 kg**

Approval number acc. to regulations EKG/ONZ 55.01: E20-55R-01 1338

Foreword

This towbar is designed according to rules of safety traffic regulations. The towing hitch is a safety component and can be install only by qualified personnel. Any alteration or conversion of the towing hitch is prohibited and would lead to cancellation of design certification. Remove insulating compound and underseal from vehicle (if present) in the area of the matting surfaces of the towing hitch. The vehicle manufacturer's specifications regarding trailer load and max. vertical cup load are decisive for driving whereat values for the towing hitch cannot be exceeded.

D-value formula:

$$\frac{\text{Max trailer weight [kg]} \times \text{Max vehicle weight [kg]}}{\text{Max trailer weight [kg]} + \text{Max vehicle weight [kg]}} \times \frac{9,81}{1000} = D \text{ [kN]}$$