

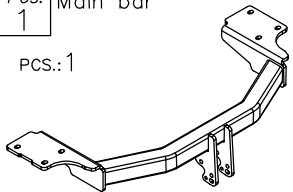

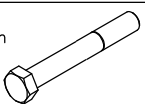





## Towing hitch accessories:

Pos. 1 Main bar PCS.: 1		Pos. 5 Bolt 8.8 B M12x150mm PCS.: 4	
		Pos. 6 Bolt 8.8 B M12x50mm PCS.: 2	
Pos. 2 Tow ball (mounting set) PCS.: 1		Pos. 7 Nut 8 B M12 PCS.: 6	
Pos. 3 Socket plate PCS.: 1		Pos. 8 Washer ø37xø13x3mm PCS.: 4	
Pos. 4 Fish-plate PCS.: 4		Pos. 9 Plain washer ø12mm PCS.: 6	
		Pos. 10 Spring washer ø12mm PCS.: 6	

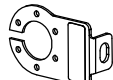

## PPUH AUTO-HAK S.J.

Produkcja Zaczepów Kulowych  
Henryk & Zbigniew Nejman  
76-200 SŁUPSK ul. Słoneczna 16K  
tel/fax (059) 8-414-414; 8-414-413  
E-mail: [office@autohak.com.pl](mailto:office@autohak.com.pl)  
[www.autohak.com.pl](http://www.autohak.com.pl)

### Towing hitch (without electrical set)

Class: **A50-X** Cat. no. **J43A**

Designed for:

Manufacturer: **HYUNDAI**

Model: **TERRACAN**

Type: **HP-1**

produced since 2001 till 2007

Technical data:

**D-value: 13,8 kN**

maximum trailer weight: **2800 kg**

maximum vertical cup mass: **115 kg**

**Approval number acc. to regulations EKG/ONZ 55.01: E20-55R-01 1831**

### Foreword

This towing hitch is designed according to rules of safety traffic regulations. The towing hitch is a safety component and can be install only by qualified personnel. Any alteration or conversion of the towing hitch is prohibited and would lead to cancellation of design certification. Remove insulating compound and underseal from vehicle (if present) in the area of the matting surfaces of the towing hitch. The vehicle manufacturer's specifications regarding trailer mass and max. vertical cup mass are decisive for driving whereat values for the towing hitch cannot be exceeded.

*D-value formula:*

$$\frac{\text{Max trailer weight [kg]} \times \text{Max vehicle weight [kg]}}{\text{Max trailer weight [kg]} + \text{Max vehicle weight [kg]}} \times \frac{9,81}{1000} = D \text{ [kN]}$$

## FITTING INSTRUCTION

Clamp mark in acc. with		Cables joining
ISO	PN	
1	L	Left directional lights
2	+	Rear fog lights
3	31	Ground
4	R	Right directional lights
5	58R	Right side parking lights
6	54	Stoplights
7	58L	Left side parking lights

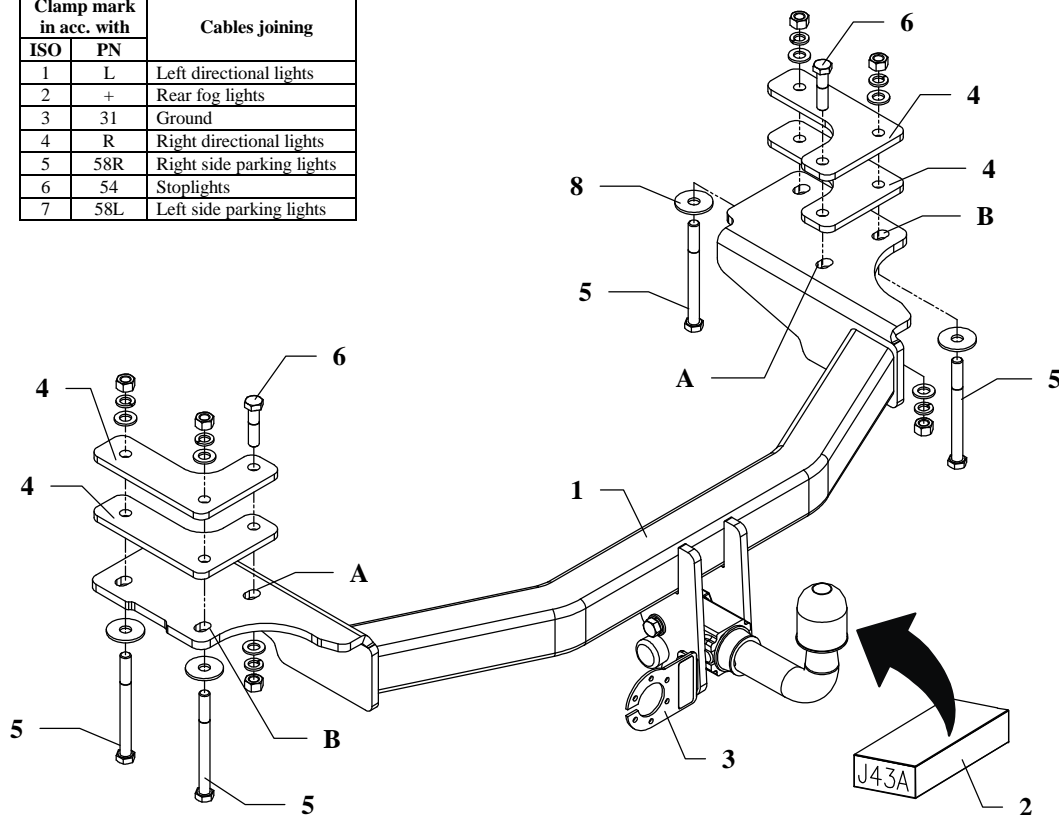

This towing hitch is designed to assembly in following cars:  
**HYUNDAI TERRACAN HP-1**, produced since 2001 till 2007, catalogue no. **J43A** and is prepared to tow trailers max total weight **2800 kg** and max vertical mass **115 kg**.

### *From manufacturer*

Thank you for buying our product. Their reliability has been confirmed in many tests. Reliability of towing hitch depends also on correct assembly and right operation. For this reasons we kindly ask to read carefully this instruction and apply to hints.

*The towing hitch should be install in points described by a car producer.*

## The instruction of the assembly

1. Put the main bar of the towing hitch (pos. 1) with fish-plates (pos. 4) in this way, so holes A and B agree with holes in chassis. Next fix it using bolts M12x150mm (pos. 5) and M12x50mm (pos. 6) as one showed on the drawing.
2. Fix body of the automat and the socket plate (pos. 3) using bolts M12x25mm from accessories. Place tow-ball according to supplied instruction.
3. Tighten all bolts according to the torque shown in the table.
4. Connect electric wires of 7-poles socket according to the instruction of the car. (Recommend to make at authorized service station).
5. Complete paint layer damaged during installation.

Torque settings for nuts and bolts (8,8):	
<b>M 8</b> - 25 Nm	<b>M 10</b> - 55 Nm
<b>M 12</b> - 85 Nm	<b>M 14</b> - 135 Nm

## NOTE

After install the towing hitch you should get adequate note in registration book (at authorised service station). The car should be equipped with:

- Indicators
- Tow mirrors

After 1000km of exploitation check all bolts and nuts. The ball of towing hitch must be always kept clear and conserve with a grease.