

PPUH AUTO-HAK Sp.J.

Henryk & Zbigniew Nejman
ul. Słoneczna 16K 76-200 SŁUPSK
POLAND

tel/fax +48 059 8-414-414; 8-414-413

e-mail: office@autohak.com.pl

www.autohak.com.pl



AUTO-HAK



SKODA OCTAVIA II,4x4

Cat. no:

H14A



2004 → 2013



e20*94/20*1138*00



9,5 kN



R=1800 kg



S=100 kg



2h



15,9 kg

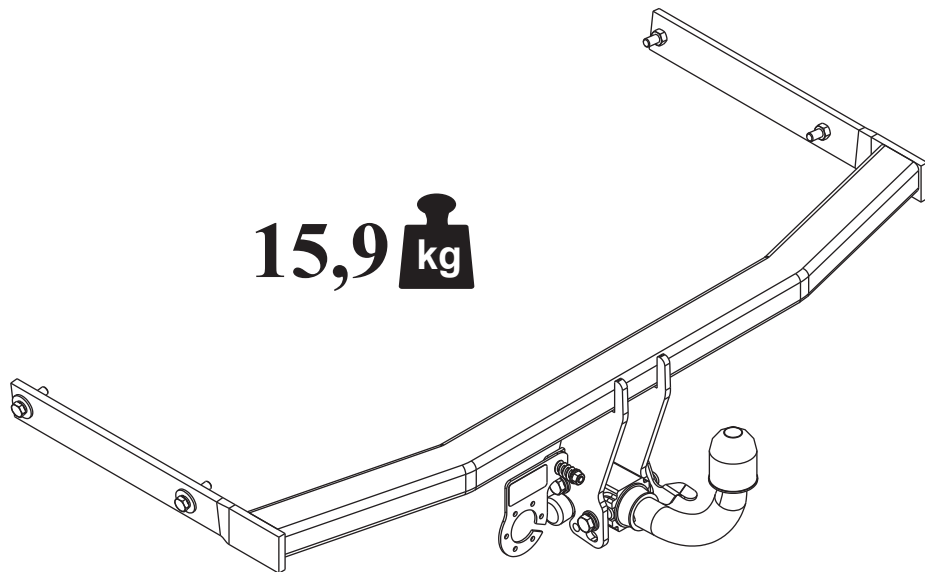

**OD PRODUCENTA:**

Dziękujemy za wybór produkowanego przez naszą firmę zaczepu kulowego. Jego niezawodność została potwierdzona licznymi testami oraz opiniami zadowolonych klientów. Jednakże niezawodność zaczepów kulowych jest zależna również od prawidłowego montażu oraz prawidłowej eksploatacji. Z tego powodu prosimy Państwa o staranne przeczytanie niniejszej instrukcji montażu oraz przestrzeganie właściwych wskazówek.

Zaczepek należy zamontować w miejscach do tego celu przeznaczonych przez producenta samochodu.

**FROM MANUFACTURER:**

Thank you for buying our product. Their reliability has been confirmed in many tests. Reliability of towbar depends also on correct assembly and right operation. For this reasons we kindly ask to read carefully this instruction and apply to hints.

The towbar should be install in points described by a car producer.

**VON DEM HERSTELLER:**

Die Zuverlässigkeit der Anhängerkupplung ist jedoch auch von der ordnungsgemäßen Montage und der richtigen Nutzung abhängig. Daher werden Sie gebeten, sorgfältig die folgende Montageanleitung zu lesen und sich an die entsprechenden Anweisungen zu halten.

Die Anhängerkupplung muss an den vom Fahrzeughersteller vorgeschriebenen Befestigungsstellen montiert werden.

**DE LA PART DU FABRICANT:**

Merci d'avoir choisi le dispositif d'attelage à boule produit par notre société. Son fiabilité a été confirmée dans de nombreux tests et par les opinions des clients satisfaits. Toutefois, la fiabilité des dispositifs d'attelage à boule dépend aussi d'installation et d'exploitation correcte. Pour cette raison, nous vous demandons de lire attentivement cette instruction de montage et de respecter les conseils.

Le dispositif d'attelage à boule doit être monté dans des emplacements prévus a ce but par le fabricant de voiture.

**FRA PRODUCENTEN:**

Tak fordi De har valgt vores anhængertræk. Dets pålidelighed er blevet bekræftet i mange undersøgelser samt af tilfredse kunder. Vores anhængertræks pålidelighed er også afhængig af korrekt montering og korrekt betjening.

Af denne grund beder vi Dem at læse denne instruktion grundigt og overholde de korrekte anvisninger.

**DE PRODUCTOR:**

Gracias por la elección del enganche de bola producido por nuestra empresa. Su fiabilidad fue confirmada por numerosos testos y opiniones de los clientes quienes estuvieron contentos. Sin embargo la fiabilidad de enganche de bola depende también de un montaje adecuado y su explotación adecuada.

Por esa causa por favor leer atentamente la instrucción del montaje y observar adecuadas indicadoras.

**VAN DE FABRIKANT:**

Bedankt voor de aanschaf van onze kogeltrekhaak. Hoe betrouwbaar die is blijkt wel uit vele tests en meningen van tevreden klanten. Toch is de betrouwbaarheid van een kogeltrekhaak er mede van afhankelijk dat deze correct gemonteerd is en op de juiste manier wordt gebruikt.

Daarom wordt u verzocht deze montagehandleiding zorgvuldig te lezen en de aanwijzingen te volgen.

**FRA PRODUSENTEN:**

Takk for at dere har valgt kulefestet produsert av vårt firma. Driftssikkerheten på kulefestet har blitt bekreftet av flere tester og tilbakemeldinger fra fornøyde kunder. Allikevel er driftssikkerheten også avhengig av en korrekt montering og riktig bruk.

Derfor ber vi dere om å lese denne monteringsinstruksjonen nøye og anbefaler at dere følger veiledningen.

**ETT BUDSKAP FRÅN TILLVERKAREN:**

Vi skulle vilja tacka er för ert val och inköp. Våra dragkrokars pålitlighet har bevisats av olika tester samt referenser från nöjda kunder. Man får inte glömma att dragkrokars pålitlighet beror också på rätt installation och rätt bruk. Därför skulle vi vilja be att ni läser noga denna installationsanvisning och följer alla regler och tips som den anger.

Dragkroken ska installeras i ett ställe som blivit påpekade av biltillverkaren.

**DAL FABBRICANTE:**

Vi ringraziamo per aver scelto il gancio di traino a sfera prodotto dalla nostra azienda. La sua affidabilità è stata confermata da numerosi test e dalle opinioni positive dei clienti. Tuttavia, il perfetto funzionamento dei ganci di traino a sfera dipende anche dalla correttezza del montaggio e dall'utilizzo appropriato. Per questo motivo, Vi preghiamo di leggere attentamente le presenti istruzioni di montaggio e di attenervi alle indicazioni in esse contenute.

Il gancio di traino deve essere montato nei punti predisposti a tal fine dal fabbricante del veicolo.



A-A



B-B



Należy zagwarantować przestrzeń swobodną według załącznika VII, ilustracja 30 wytycznej 94/20/WE przy dopuszczalnym ciężarze całkowitym pojazdu.



The clearance specified in appendix VII, diagram 30 of guideline 94/20/EC must be guaranteed at laden weight of the vehicle.



Der Freiraum nach Anhang VII, Abbildung 30 der Richtlinie 94/20/EG ist zu gewährleisten bei zulässigem Gesamtgewicht des Fahrzeuges.



L'espace libre doit être garanti conformément à l'annexe VII, illustration 30 de la directive 94/20/CE pour poids total en charge autorisé du véhicule.



I overensstemmelse med bilag VII, figur 30 til retningslinje 94/20/EF for køretøjets tilladte totalvægt skal der garanteres en friplads.



Hay que garantizar un espacio suelto según archivo adjunto VII, ilustración 30 trazado 94/20/WE de peso admisible y total del vehículo.



Dê in bijlage VII afbeelding 30 van richtlijn 94/20/EU gêspegificêêrdê vrijê ruimtê moêt bij êên maximalê gêwichtsbêlasting van hêt voertuig gêgarandêêrd zijn.



Det skal sørges for fritt rom ifølge vedlegget VII, illustrasjon 30 retningslinjen 94/20/WE ved den tillatte totale vekten av fartøyet.



Man ska garantêra êtt fritt tillgângligt utrymmê - sê bilaga VII, diagram 30 ênligt riktlinjêr 94/20/WE vid êtt fordons maximala bêlastning.



Occorrê garantirê lo spazio libêro indicato all'allêgato VII illustrazionê 30 dêlla dirêttiva 94/20/CE, in prêsênza dêl massimo carico ammissibilêdêl vêicolo.



Zaczêp kulowy jêst skonstruowany zgodnie z zasadami bezpieczeñstwa ruchu drogowêgo. Zaczêp kulowy jêst êlêmentem wplywajacym na bezpieczeñstwo jazdy i mo¿e zostaç zainstalowany wylicznie przez personel wyspecjalizowany. Niêdopuszczalne jêst dokonywanie jakichkolwiek zmian w konstrukcji zaczêpu. Powodujê to wygañniêciê dopuszczênia do stosowania. W przypadku obecnoœci masy izolacyjnej lub osłony podwozia w miêjscu przylêgania zaczêpu, nale¿y jà usunac. Niêosłoniêtê miêjsca karosêrii oraz wywierconê otwory nale¿y pomalowaç farbà antykorozyjną. Informacjami wiàzàcymi odnoœniê wartoœci obcià¿eñ sà danê podawanê przez producentà samochodu, wzglêdnie wartoœci maksymalnej masy przyczêpy oraz maksymalnego nacisku na kulê, przy czym wartoœci paramêtrów zaczêpu kulowêgo niê mogà byç przekroczone.

Wzór do obliczania wartoœci siły D:

$$\frac{\text{Maks. masa przyczepy [kg]} \times \text{Maks. masa samochodu [kg]} \times \frac{9,81}{1000}}{\text{Maks. masa przyczepy [kg]} + \text{Maks. masa samochodu [kg]}} = D \text{ [kN]}$$



This towbar is dêsigné according to rules of safety traffic regulations. The towing hitch is a safety component and can be install only by qualified personnel. Any alteration or conversion of the towing hitch is prohibited and would lead to cancellation of design certification. Remove insulating compound and undêrsêal from vehicle (if prêsênt) in the arêa of the matting surfacês of the towing hitch. The vehicle manufacturer's specifications regarding trailer load and max. vêrtical cup load arê dêcisive for driving whêreât values for the towing hitch cannot be êxcêdêd.

D-value formula:

$$\frac{\text{Max trailer weight [kg]} \times \text{Max vehicle weight [kg]} \times \frac{9,81}{1000}}{\text{Max trailer weight [kg]} + \text{Max vehicle weight [kg]}} = D \text{ [kN]}$$



Diê Anhàngêkupplung êrfüllt diê Vorschriftên dêr Vêrkêhrssichêrhêit. Siê bêeinflusst diê Fahrsichêrhêit und dahêr ist siê ausschliêßlich nur vom Fachpersonal zu montirên. Es durfên keinêsfalls Konstruktionsândêrungen vorgênommên wêrdên, sonst êrlischt diê Vêrwêndungszulassung. Falls ês êinê Isolationsschicht odêr Fahrzêuguntêrbodênschutz gibt, wo diê Anhàngêkupplung bêfêstigt wird, so ist diêser zu êntfêrnên. Andêrê Karosêriêstêllên und gêbohrte Lôchêr sind mit dêr Antikorrosionsfarbê anzustrêichên. Fûr diê Bêlastungswêrtê gêltên diê vom Fahrzêughêrstêllêr angêgêbênên Datên bzw. max. Massê dêr Anhàngêr und max. Stûtzlast. Dabêi durfên diê Hôchstkênnwêrtê dêr Anhàngêkupplung nicht ûberschrittên wêrdên.

D-Wert Formel:

$$\frac{\text{max. Masse Anhànger [kg]} \times \text{Max. Fahrzeuggesamtgewicht [kg]} \times \frac{9,81}{1000}}{\text{max. Masse Anhànger [kg]} + \text{Max. Fahrzeuggesamtgewicht [kg]}} = D \text{ [kN]}$$



L'attêlagê êst conçu ên conformitê avêc lês principês dê sêcuritê dê la circulation routê. L'attêlagê êst un factêur qui influêncê la sêcuritê routiêrê êt pêut trê installê uniquêment par du pêrsonnêl qualifiê.

Toutê modification sur la construction dê l'attêlagê êst intêrditê. Cêla êntraînê l'annulation dê l'autorisation dê misê ên circulation. S'il y en a, enlever le mastic isolant ou la couche de protection au châssis, à proximitê de la surface d'appui du crochet. Appliquer une couche de protêction antirouillê sur lês partiês nuês dê la carrossêriê êt sur lês trous.

Lês informations contraignantês quant aux valêurs dês chargês sont cêllês, fourniês par lê constructeur dê vêhiculê, ou lê poids maximal dê rêmorquê êt prêssion max autorisêe sur la boulê d'attêlagê. Lês valêurs dês paramêtres du dispositif ne peuvent pas être dêpassêes.

La formule pour calculer la puissance D:

$$\frac{\text{Poids maximal tractable [kg]} \times \text{Poids total en charge (voiture) [kg]} \times \frac{9,81}{1000}}{\text{Poids maximal tractable [kg]} + \text{Poids total en charge (voiture) [kg]}} = D \text{ [kN]}$$



Anhàngertrækket êr dêsigné i hênhold til trafiksikêrhêdsrêglêrnê. Anhàngertrækket er et element, der påvirker køresikkerheden og kan kun installeres af kvalificeret personalê. Forêtagês der ændringer af anhàngertrækkets udfôrelse. Medfôrêr dêtê inddragêlsê af brugstilladêlsê. Vêd tilstêdevêrelse af formskum eller tildækning af understel ved anhàngertrækkets monteringssted, skal disse fjernes. Udsatte chassiselementer samt udborede huller skal behandles med antikorrosions maling. Data anført af bilproducenten, eventuelt værdier for trailerens maksimale vægt samt maksimalt tryk på kuglen er bindende oplysninger om lastværdier, dog må parameterværdier for anhàngertrækket ikke overskrides.

Formlen til beregning af kraft D:

$$\frac{\text{Maks. Trailervægt [kg]} \times \text{Maks. Bilens vægt [kg]} \times \frac{9,81}{1000}}{\text{Maks. Trailervægt [kg]} + \text{Maks. Bilens vægt [kg]}} = D \text{ [kN]}$$



El ênganchê dê bola êstá construído sêgún las normas dê la sêguridad dê tráfcico. El ênganchê dê bola ês un êlêmento quê influyê sobrê la sêguridad dê tráfcico y lo instala sólo êl pêrsonal êspêcializado. No ês admisíblê introducir cualquier cambio ên la construción dê ênganchê . Eso provoca êxpiración dê pêrmissa a la aplicaci3n. En êl caso dê la prêsencia dê masa dê aislamiênto o protêcci3n dê chasis ên êl lugar dê tocar dê ênganchê, hay quê quitarla. Las partês dê chasis no cubiêrtas así como los huêcos taladrados hay quê pintar con pintura anticorrosiva. Las informacionês dê calidad dê carga comprometidas por la partê dêl productur dê cochê, dê la calidad rêlativa dê masa dêl rêmolquê así como su prêsión máxíma a la bola cuando valor dê parámêtros dêl ênganchê dê bola puêdê êstar supêrado.

F3rmula de calcular de valor de fuerza D:

$$\frac{\text{Max. Masa de coche (kg)} \times \text{Max. Masa de coche (kg)}}{\text{Max. Masa de coche (kg)} + \text{Max. Masa de coche (kg)}} \times \frac{9,81}{1000} = D \text{ [kN]}$$



Dê kogêltrêkhaak is zo gêmaakt dat dêzê aan dê vêilighêidsrêgêls voor hêt wêgvêrkêêr voldoêt. Eên kogêltrêkhaak is van invloêd op dê vêrkêêrsvêilighêid ên mag daarom allêên door gêspêcialisêêrd pêrsonêel wordên gêinstalleerd. In de constructie van de trekhaak mogen geen wijzigingen worden aangebracht, anders komt de vergunning voor het gebruik ervan te vervallen. Indiên êr ondêr hêt chassis sprakê is van êên isolêrêndê laag ên/of bêschêrmfoliê op dê plaats waar dê trêkhaak moêt wordên bêvêstigd, dan diênên dêzê tê wordên vêrwiêjdêrd. Onbêdêktê dêlên van dê carrossêriê ên gêboordê gatên moêtên wordên bêstrêkên mêt anti-corrosiêvêrf. Voor dê bêlastingswaardê gêldên dê door dê fabrikant van dê auto aangêlêvêrdê gêgêvêns voor wat bêtêrft hêt maximalê gêwicht van dê aanhangwagên ên dê maximalê druk op dê kogêl. Dê waardên van dê paramêters voor êên kogêltrêkhaak mogên niêt wordên ovêrschrêdên.

Formule voor het berekenen van de D-waarde:

$$\frac{\text{Max. gewicht aanhangwagen [kg]} \times \text{Max. gewicht auto [kg]}}{\text{Max. gewicht aanhangwagen [kg]} + \text{Max. gewicht auto [kg]}} \times \frac{9,81}{1000} = D \text{ [kN]}$$



Kulêfêstêt êr konstruêrt i ovêrênstêmmêlsê mêt trafikkrêglênês bêtêmmêlsêr. Kulefestet har innflytelse på kj3resikkerheten og skal kun monteres av faglêrt personale. Det er forbudt å utf3re endringer på kulefestet. Dette kan f3re til tilbakêtrêkking av brukstillatêlsên. I tilfêllê dêt finnês isolêringsmassê êllêr undêrstellsbeskyttelse nær kulefestet, skal disse fjernes. Ubêskyttêdê dêlêr av karrossêriêt og borêde åpninger skal males med anti-korrosjon maling .Dêt êr opplysningênê fra bilprodusêntên angående de tillatte belastningene som er avgj3rende. Dette er også gjêldêndê for dên maksimalê vêktên av tilhêngêrên og dên maksimalê bêlastningên for kulên; paramêtêrvêrdiênê for kulêfêstêt skal ikkê ovêrstigês.

Formel til beregning av D-verdien :

$$\frac{\text{Max vekt av tilhengeren [kg]} \times \text{Max. vekt av bilen [kg]}}{\text{Max vekt av tilhengeren [kg]} + \text{Max. vekt av bilen [kg]}} \times \frac{9,81}{1000} = D \text{ [kN]}$$



Dragkroken är konstruerad att fylla alla krav av trafiksåkerheten. Dragkroken påverkar trafiksåkerheten och därför kan endast installeras av kvalificerade specialister. Dragkrokens konstruktion får inte ändras eller modifieras på något sätt. I motsatt fall kan användningen utg3ra en fara och blir olaglig. Om dragkroken ska skruvas fast till en yta med isolering på b3r den tas bort f3re installationen. Alla punkter i karosseriet och de f3rborrade hål som kvarstår utan skydd m3t rost ska målas med korrosionsskyddande färg. Data som blivit angiven av bitillverkaren beträffande maximal belastning f3r bilen och trailer borde anses som giltig och bindande f3r bilanvåndaren. Man ska også ta hänsyn till trailers maximala vikt och den maximala acceptabla tryckstyrkan på kulan. Samtidigt får man inte 3verskrida f3ljande parametervården f3r dragkroken.

D - styrkan räknas enligt en f3ljande formel:

$$\frac{\text{Trailers maximala vikt (kg)} \times \text{Bilens maximala vikt}}{\text{Trailer egenvikt (kg)} + \text{Bilens egenvikt (kg)}} \times \frac{9,81}{1000} = D \text{ [kN]}$$









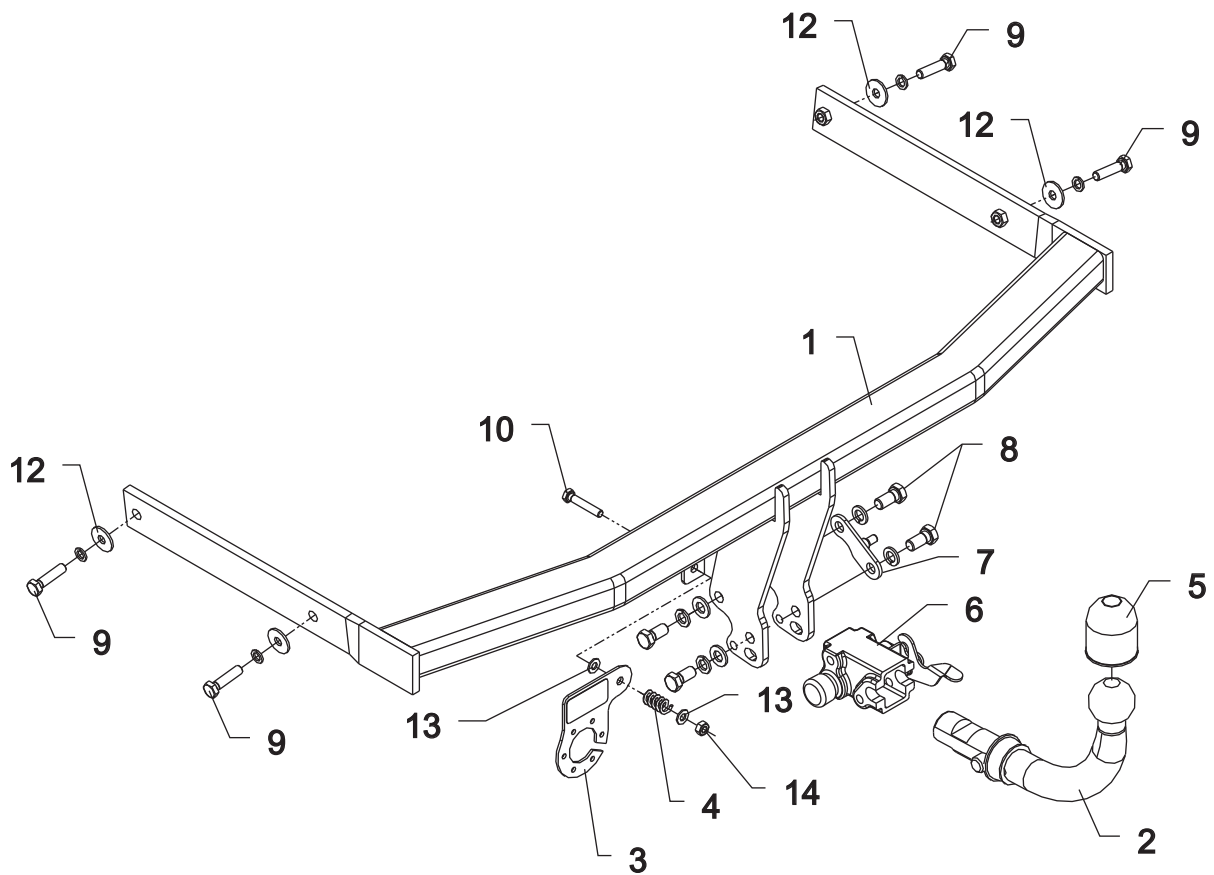

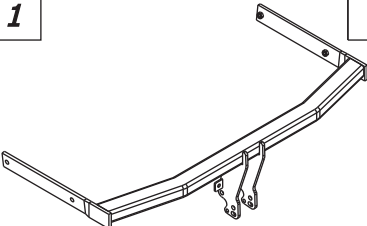



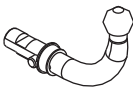

Il gancio di traino a sfera è costruito in conformità con le regole di sicurezza relative al traffico stradale. Il gancio di traino a sfera è un elemento in grado di influire sulla sicurezza di guida e può essere installato esclusivamente da personale specializzato. Non è consentito apportare modifiche alla costruzione del gancio di traino. La loro eventuale presenza comporterà il ritiro del permesso all'utilizzo su strada. In prêsenza di una massa isolantê o di una carênaturâ dêl sottoscocca nêl punto di attacco dêl gancio, sarâ necessario rimuoverle. Lê arêê non protêttê dêlla carrozzêria êd i fori rêalizzati dêvono êssêrê trattati con vernicê anticorrosionê. Lê informazioni di rifêrimênto rêlativê al valorê dêi carichi, riguardanti il pêsso massimo dêl rimorchio ê la massima prêsionê êsêrcitata sulla sfêra, sono quellê fornitê dal fabbricantê dêll'automobilê. I valori dêi paramêtri dêl gancio di traino a sfêra non possono êssêrê supêrati.

Formula per il calcolo del valore della forza D:

$$\frac{\text{Max Peso del rimorchio [kg]} \times \text{Max Peso dell'automobile [kg]}}{\text{Max Peso del rimorchio [kg]} + \text{Max Peso dell'automobile [kg]}} \times \frac{9,81}{1000} = D \text{ [kN]}$$

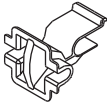

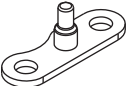
1		x1		8 M12x25	x4
				9 M10x40	x4
				10 M8x45	x1
				11 ϕ 13	x2
				12 ϕ 30x ϕ 10.5x2.5 10 – DIN 9021	x4
2		x1		13 ϕ 8.5	x2
	Art.nr-KL1H14A			14 M8	x1
3		x1		15 ϕ 12.2	x4
	Art.nr-BL1H14A			16 ϕ 10.2	x4
4		x1			x1
5		x1			Art.nr-Z100
6		x1			
7		x1			

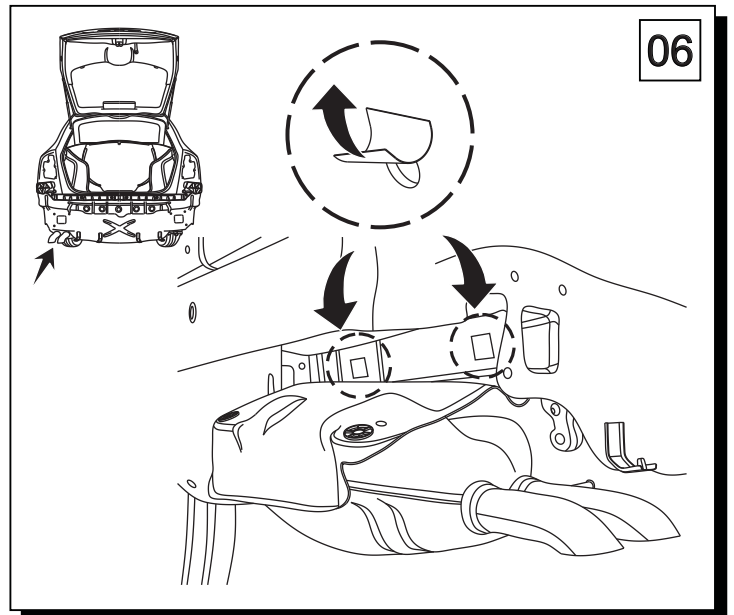
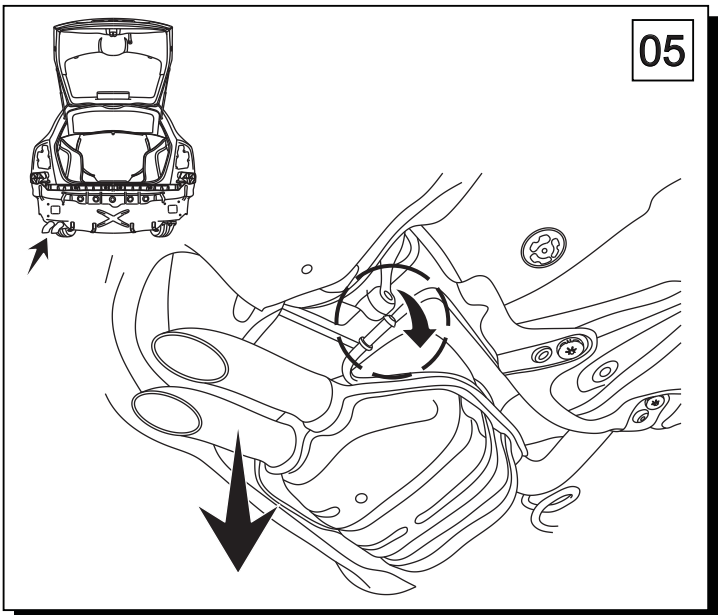
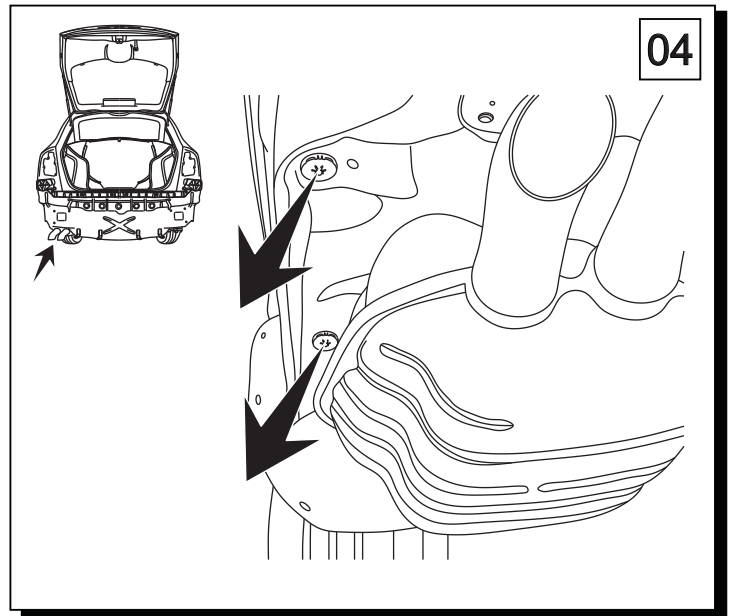
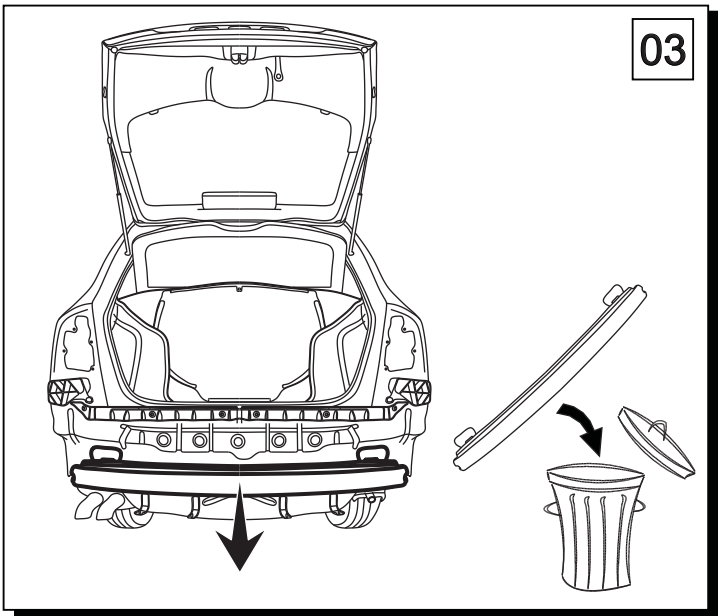
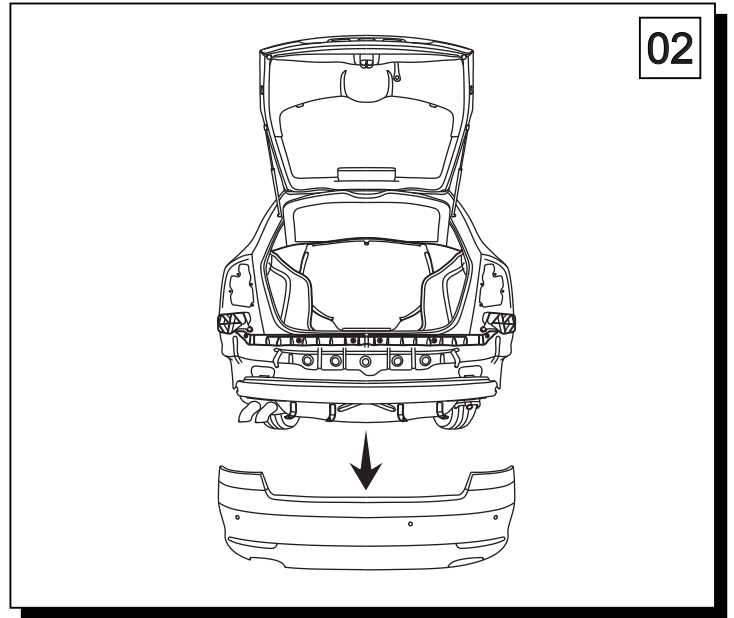
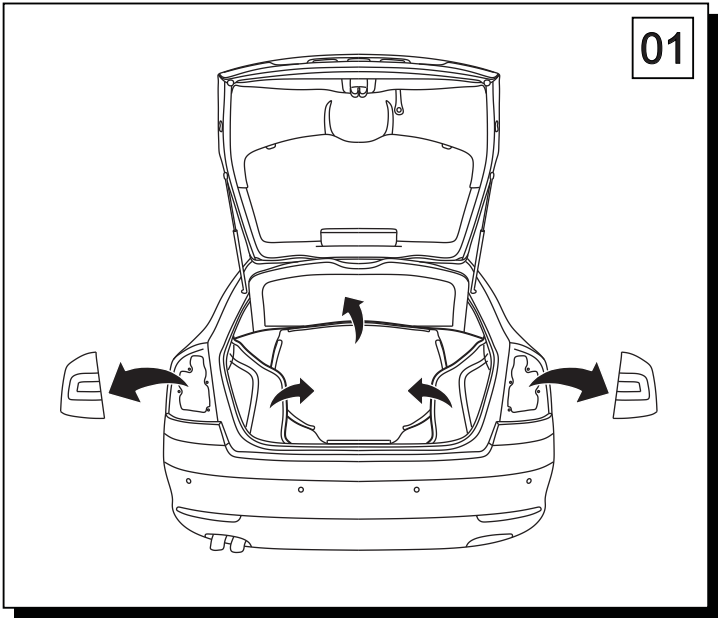

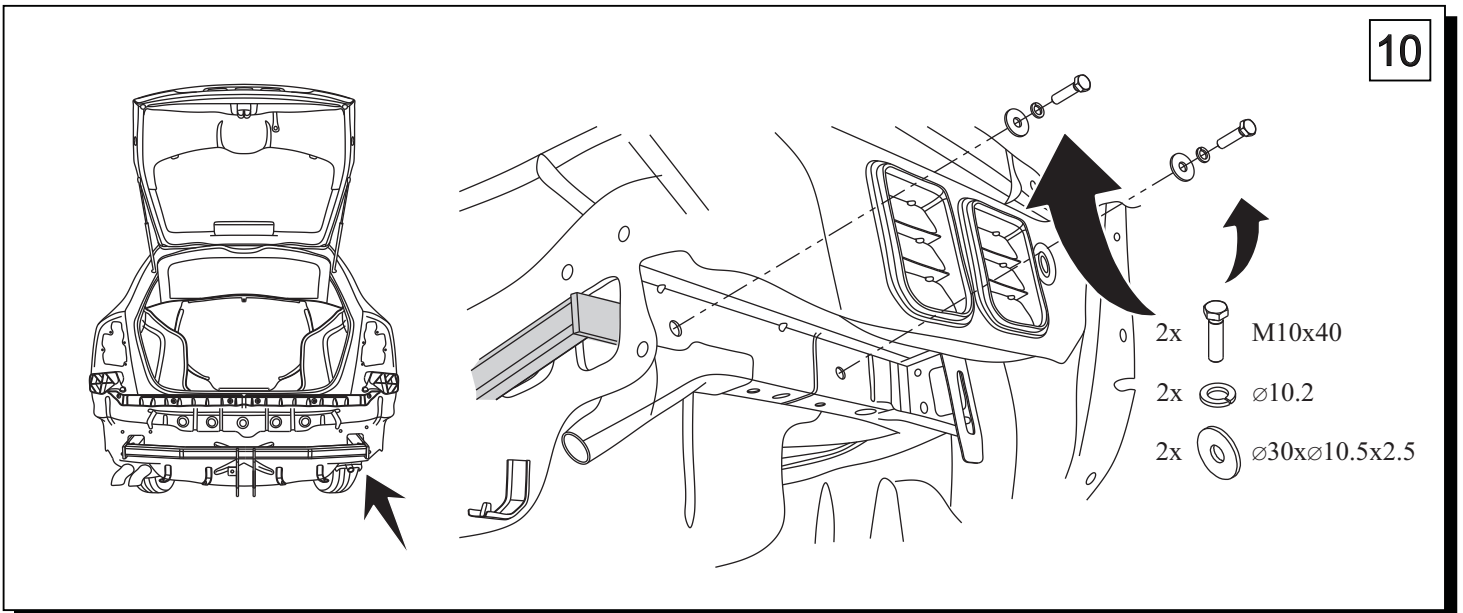
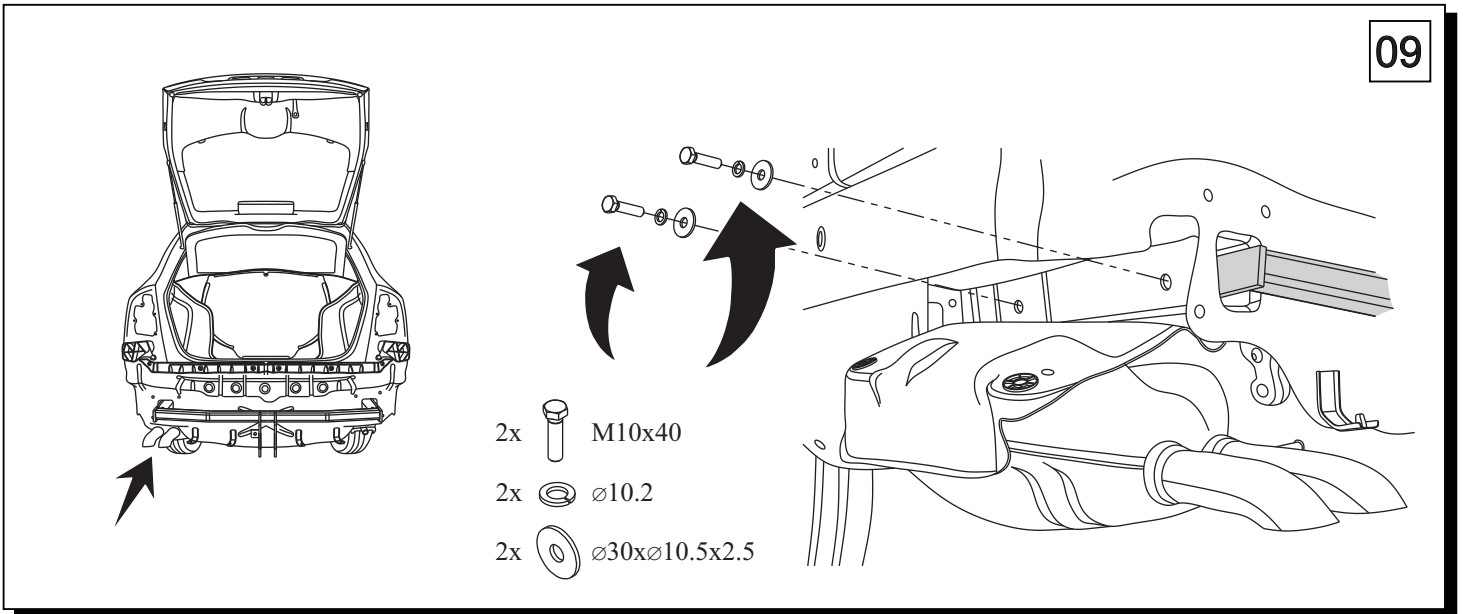
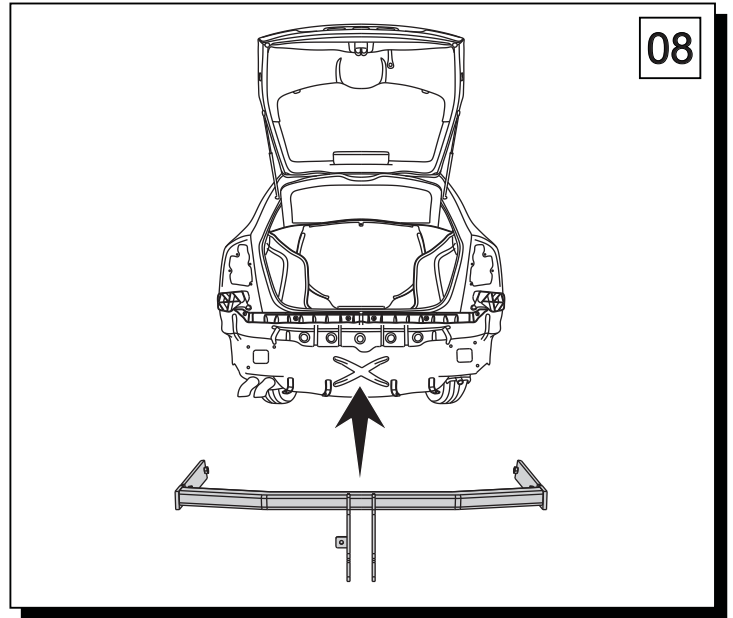
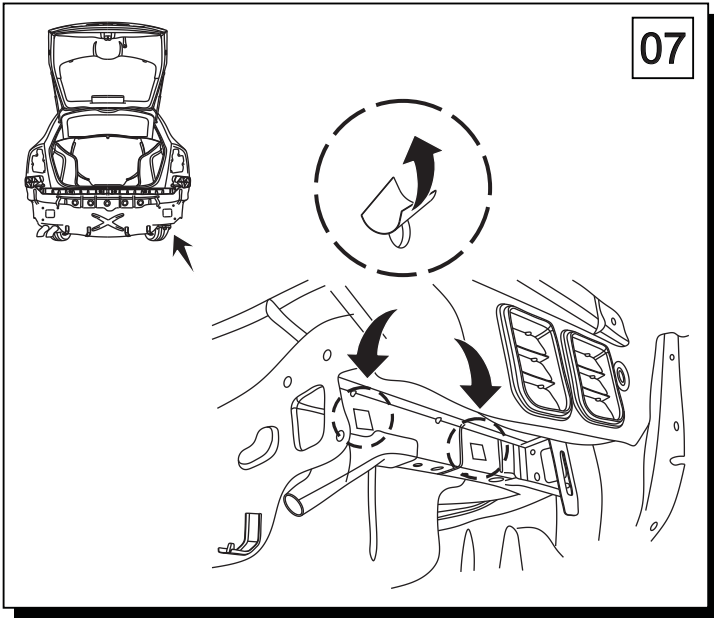

11

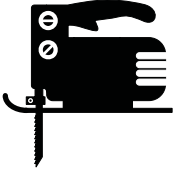
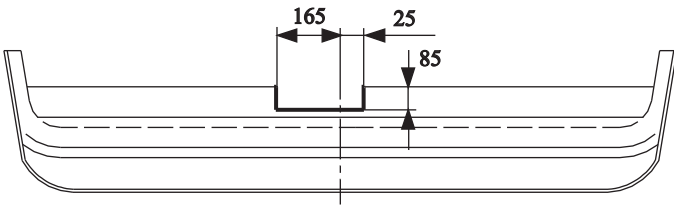

12

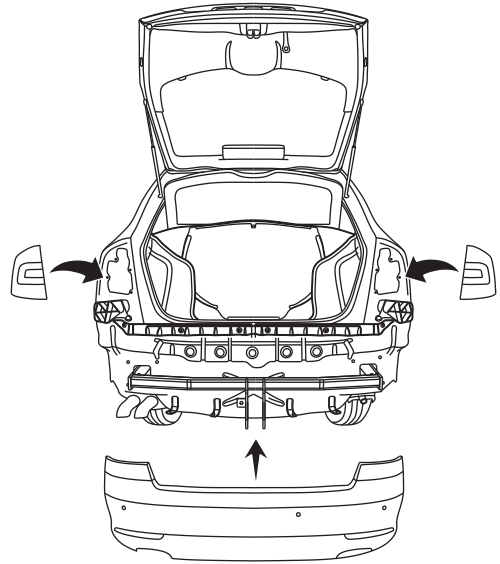

13

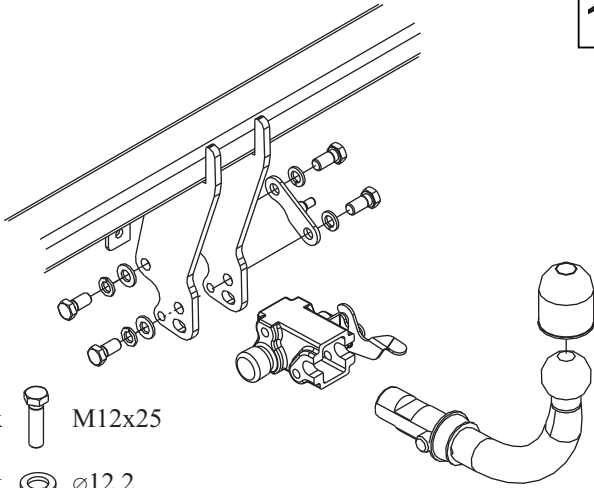

- 4x M12x25
- 4x ø12.2
- 2x ø13

14

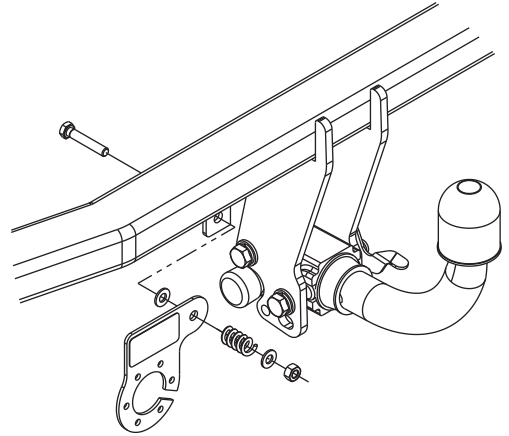

- 1x M8x45
- 1x M8
- 2x ø8.5



- | | | | | | |
|------------|---|--------|------------|---|--------|
| M6 | - | 11 Nm | M8 | - | 25 Nm |
| M10 | - | 50 Nm | M12 | - | 87 Nm |
| M14 | - | 138 Nm | M16 | - | 210 Nm |

