

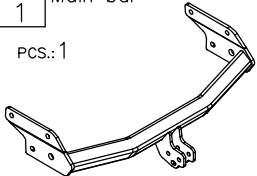

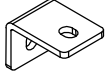







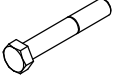

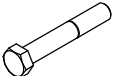

## Towing hitch accessories:

|  |   |  |
|--|---|--|
| Pos. 1<br>Main bar<br>PCS.: 1<br>         | Pos. 5<br>Angle bar<br>pcs.: 2<br>           | Pos. 11<br>Nut 8 B M12<br>PCS.: 4<br>           |
|  | Pos. 6<br>Bolt 8,8 B M12x75mm<br>PCS.: 1<br> | Pos. 12<br>Plain washer ø13mm<br>PCS.: 11<br>   |
| Pos. 2<br>Tow ball<br>pcs.: 1<br>         | Pos. 7<br>Bolt 8,8 B M12x70mm<br>PCS.: 1<br> | Pos. 13<br>Plain washer ø10,5mm<br>PCS.: 3<br>  |
| Pos. 3<br>Socket plate<br>pcs.: 1<br>     | Pos. 8<br>Bolt 8,8 B M12x40mm<br>PCS.: 5<br> | Pos. 14<br>Spring washer ø12,2mm<br>PCS.: 7<br> |
| Pos. 4<br>Jib with the nut<br>pcs.: 3<br> | Pos. 9<br>Bolt 8,8 B M10x35mm<br>PCS.: 3<br> | Pos. 15<br>Spring washer ø10,2mm<br>PCS.: 3<br> |
|  | Pos. 10<br>Washer ø37xø13x3mm<br>PCS.: 1<br> | Pos. 16<br>Ball cover<br>PCS.: 1<br>            |



**PPUH AUTO-HAK S.J.**

Produkcja Zaczepów Kulowych  
Henryk & Zbigniew Nejman  
76-200 SŁUPSK ul. Słoneczna 16K  
tel/fax (059) 8-414-414; 8-414-413  
E-mail: [office@autohak.com.pl](mailto:office@autohak.com.pl)  
[www.autohak.com.pl](http://www.autohak.com.pl)

## Towing hitch (without electrical set)

Class: **A50-X** Cat. no. **E49**

Designed for:

Manufacturer: **OPEL**

Model: **SINTRA**

produced since 1996 till 1999 and

Manufacturer: **CHEVROLET**

Model: **TRANS SPORT**

produced since 1997 till 2006

Technical data:

**D-value: 10,9 kN**

maximum trailer weight: **2000 kg**

maximum vertical cup load: **75 kg**

**Approval number according to Directive 94/20/EC: e20\*94/20\*0099\*00**

## Foreword

This towing hitch is designed according to rules of safety traffic regulations. The towing hitch is a safety component and can be install only by qualified personnel. Any alteration or conversion of the towing hitch is prohibited and would lead to cancellation of design certification. Remove insulating compound and underseal from vehicle (if present) in the area of the matting surfaces of the towing hitch.

The vehicle manufacturer's specifications regarding trailer load and max. vertical cup load are decisive for driving whereat values for the towing hitch cannot be exceeded.

*D-value formula:*

$$\frac{\text{Max trailer weight [kg]} \times \text{Max vehicle weight [kg]}}{\text{Max trailer weight [kg]} + \text{Max vehicle weight [kg]}} \times \frac{9,81}{1000} = D \text{ [kN]}$$

## FITTING INSTRUCTION

| Clamp mark in acc. with |     | Cables joining            |
|-------------------------|-----|---------------------------|
| ISO                     | PN  |                           |
| 1                       | L   | Left directional lights   |
| 2                       | +   | Rear fog lights           |
| 3                       | 31  | Ground                    |
| 4                       | R   | Right directional lights  |
| 5                       | 58R | Right side parking lights |
| 6                       | 54  | Stoplights                |
| 7                       | 58L | Left side parking lights  |

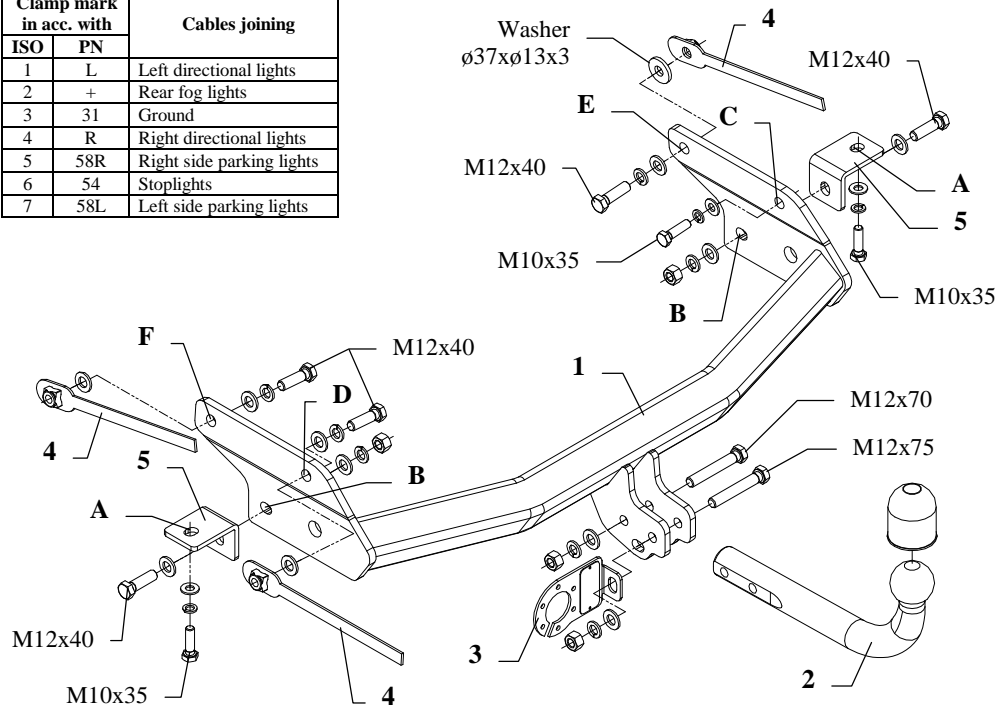

Fig. 1

This towing hitch is designed to assembly in following cars: **OPEL SINTRA** produced since 1996 till 1999 and **CHEVROLET TRANS SPORT**, produced since 1997 till 2006, catalogue no. **E49** and is prepared to tow trailers max total weight **2000 kg** and max vertical load **75 kg**.

|   |                      |
|---|----------------------|
| Torque settings for nuts and bolts (8,8): |                      |
| <b>M 8 - 25 Nm</b>                        | <b>M 10 - 55 Nm</b>  |
| <b>M 12 - 85 Nm</b>                       | <b>M 14 - 135 Nm</b> |

### From manufacturer

Thank you for buying our product. Their reliability has been confirmed in many tests. Reliability of towing hitch depends also on correct assembly and right operation. For this reasons we kindly ask to read carefully this instruction and apply to hints.

*The towing hitch should be install in points described by a car producer.*

## The instruction of the assembly

1. Take out a spare wheel. Remove two bolts from the towing eye: one from underneath and one from the left side.
2. Fix loosely right angle bar (pos. 5) to the right side of the chassis through hole (pos. A) using bolt M10x35mm (pos. 9).

**For models without level adjustment:** Fix loosely left angle bar (pos. 5) to the left side of the chassis through hole (pos. A) using bolt M10x35mm (pos. 9).

**For models with level adjustment:** Remove bolt X shown in figure 2, place angle bar (pos. 5) between just removed plate and the chassis. Fix loosely using bolt M10x35mm.

**For Chevrolet Trans Sport:** Underneath the bumper, in central section cut out its fragment: width 50mm and depth 40mm. Cut out fragment of bumper reinforcement according to figure 3. Disassemble original towing eye. Put the pin for the rearmost exhaust through hole ø19mm in towing hitch brackets. Mount the towing hitch together with the towing eye on the car.

3. Between installed angle bars put the main bar of the towing hitch (pos. 1) and fix using bolts M12x40mm (pos. 8) through holes (pos. B).
4. On the right side insert bolt M10x35mm in point (pos. C). On the left side insert bolt M12x40mm through hole (pos. D), use nut on the jib (pos. 4). Position the towing hitch horizontally. Drill holes (pos. E and F) in chassis members using bit ø13mm.
5. Fix the main bar of the towing hitch through holes (pos. E and F) using bolts M12x40mm and nuts on the jibs (pos. 4). On the left side remember about big washer ø37xø13x3mm (pos. 10), see figure 1.
6. Fix tow-ball (pos. 2) with socket plate (pos. 3) using bolts M12x75mm (pos. 6) and M12x70mm (pos. 7) from accessories.
7. Tighten all bolts according to the torque shown in the table.
8. Connect electric wires of 7-poles socket according to the instruction of the car. (Recommend to make at authorized service station).
9. Complete paint layer damaged during installation.

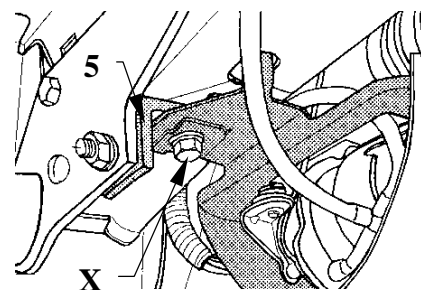

Fig. 2

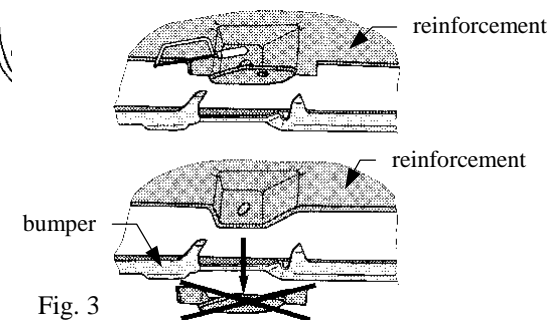

Fig. 3

### NOTE

After install the towing hitch you should get adequate note in registration book (at authorised service station).The car should be equipped with:

- Indicators
- Tow mirrors

After 1000km of exploitation check all bolts and nuts. The ball of towing hitch must be always kept clear and conserve with a grease.