

FITTING INSTRUCTION

Clamp mark in acc. with		Cables joining
ISO	PN	
1	L	Left directional lights
2	+	Rear fog lights
3	31	Ground
4	R	Right directional lights
5	58R	Right side parking lights
6	54	Stoplights
7	58L	Left side parking lights

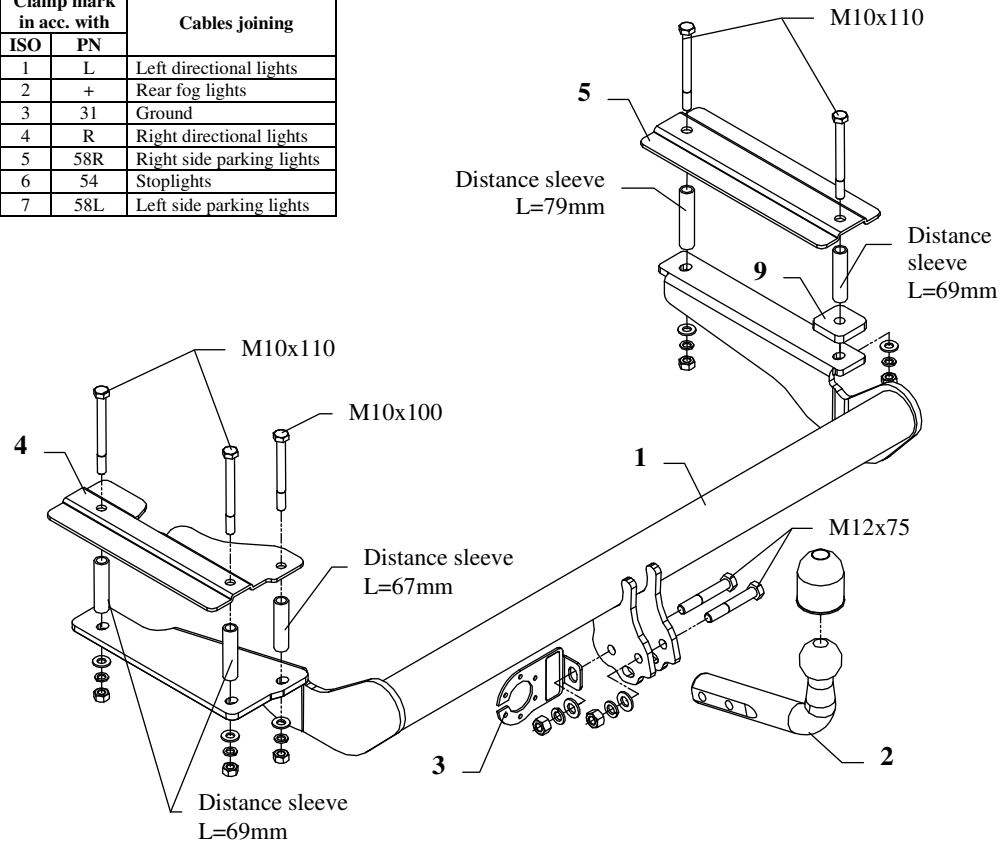

This towbar is designed to assembly in following cars:
OPEL VECTRA “B” ESTATE, produced since 1996 till 2003, catalogue number **E27** and is prepared to tow trailers max total weight **1700 kg** and max vertical mass **75 kg**.

From manufacturer

Thank you for buying our product. Their reliability has been confirmed in many tests. Reliability of towbar depends also on correct assembly and correct exploitation. For this reasons we kindly ask to read carefully this instruction and apply to hints.

The towbar should be install in points described by a car producer.

To install the towbar you need electric drill and bit $\phi 17\text{mm}$.

The instruction of the assembly

1. Disassemble a bumper, and pull a boot carpet back.
2. Find two marked holes on the right and drill it $\phi 17\text{mm}$.
3. Find three marked holes on the left and drill it $\phi 17\text{mm}$.
4. Put distance sleeves through the just made holes and position elements (pos. 4 and 5), then put bolts M10 (pos. 11 and 12) (as it shown in the drawing).
5. Position element (pos. 1) on the sticking bolts out.
6. Reassemble the bumper (earlier take a foam out the bumper)
7. Fix tow-ball (pos. 2) and socket plate (pos. 3) using bolts M12x75mm (pos. 10) from accessories.
8. Tighten all bolts according to the torque shown in the table.
9. Connect electric wires of 7-poles socket according to the instruction of the car. (Recommend to make at authorized service station)
10. Complete paint layer damaged during installation.

Torque settings for nuts and bolts (8,8):	
M 8 - 25 Nm	M 10 - 55 Nm
M 12 - 85 Nm	M 14 - 135 Nm











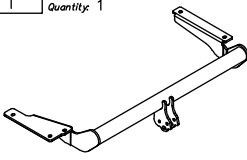
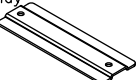
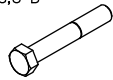

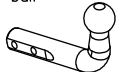
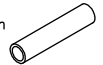
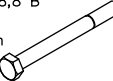
NOTE

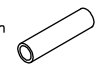
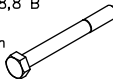
After install the towbar you should get adequate note in registration book (at authorised service station).The car should be equipped with:

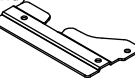
- Indicators
- Tow mirrors

After 1000km of exploitation check all bolts and nuts. The ball of towbar must be always kept clear and conserve with a grease.

Towbar accessories:

Pos. 1 Name: Main bar Quantity: 1 	Pos. 5 Name: Overlay Quantity: 1 	Pos. 10 Name: Bolt 8,8 B Quantity: 2 Dim.: M12x75mm 	Pos. 15 Name: Plain washer Quantity: 2 Dim.: Ø 13 mm 
Pos. 2 Name: Tow ball Quantity: 1 	Pos. 6 Name: Distance sleeve Quantity: 1 Dim.: Ø17,2 L=79mm 	Pos. 11 Name: Bolt 8,8 B Quantity: 4 Dim.: M10x110mm 	Pos. 16 Name: Plain washer Quantity: 5 Dim.: Ø 10,5 mm 
Pos. 3 Name: Socket plate Quantity: 1 	Pos. 7 Name: Distance sleeve Quantity: 3 Dim.: Ø17,2 L=69mm 	Pos. 12 Name: Bolt 8,8 B Quantity: 1 Dim.: M10x100mm 	Pos. 17 Name: Spring washer Quantity: 2 Dim.: Ø 12,2 mm 
Pos. 4 Name: Overlay Quantity: 1 	Pos. 8 Name: Distance sleeve Quantity: 1 Dim.: Ø17,2 L=67mm 	Pos. 13 Name: Nut 8 B Quantity: 2 Dim.: M12 	Pos. 18 Name: Spring washer Quantity: 5 Dim.: Ø 10,2 mm 
	Pos. 9 Name: Square washer Quantity: 1 	Pos. 14 Name: Nut 8 B Quantity: 5 Dim.: M10 	Pos. 19 Name: Ball cover Quantity: 1 



PPUH AUTO-HAK S.J.

Produkcja Zaczepów Kulowych
Henryk & Zbigniew Nejman
76-200 SŁUPSK ul. Słoneczna 16K
tel/fax (059) 8-414-414; 8-414-413
E-mail: office@autohak.com.pl
www.autohak.com.pl

Towing hitch (without electrical set)

Class: **A50-X** Cat. no. **E27**

Designed for:

Manufacturer: **OPEL**

Model: **VECTRA "B"**

Type: **ESTATE**

produced since 1996 till 2003

Technical data:

D-value: 9,22 kN

maximum trailer weight: **1700 kg**

maximum vertical cup mass: **75 kg**

Approval number acc. to regulations EKG/ONZ 55.01: **E20-55R-01 1170**

Foreword

This towbar is designed according to rules of safety traffic regulations. The towing hitch is a safety component and can be install only by qualified personnel. Any alteration or conversion of the towing hitch is prohibited and would lead to cancellation of design certification. Remove insulating compound and underseal from vehicle (if present) in the area of the matting surfaces of the towing hitch.

The vehicle manufacturer's specifications regarding trailer load and max. vertical cup load are decisive for driving, and values for the towing hitch cannot be exceeded.

D-value formula:

$$\frac{\text{Max trailer weight [kg]} \times \text{Max vehicle weight [kg]}}{\text{Max trailer weight [kg]} + \text{Max vehicle weight [kg]}} \times \frac{9,81}{1000} = D \text{ [kN]}$$