

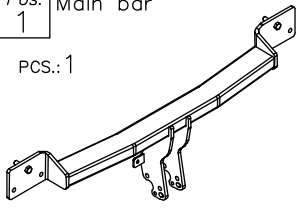

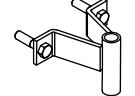







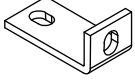

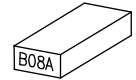

## Towing hitch accessories:

<p>Pos. 1 Main bar</p> <p>PCS.: 1</p> 	<p>Pos. 6 Handle</p> <p>PCS.: 2</p> 	<p>Pos. 12 Plain washer Ø10.5mm</p> <p>PCS.: 4</p> 
	<p>Pos. 7 Angle bracket</p> <p>PCS.: 2</p> 	<p>Pos. 13 Spring washer Ø12.2mm</p> <p>PCS.: 6</p> 
<p>Pos. 2 Tow ball</p> <p>PCS.: 1</p> 	<p>Pos. 8 Spring</p> <p>PCS.: 1</p> 	<p>Pos. 14 Spring washer Ø10.2mm</p> <p>PCS.: 4</p> 
<p>Pos. 3 Socket plate</p> <p>PCS.: 1</p> 	<p>Pos. 9 Bolt 8,8 B M10x35mm</p> <p>PCS.: 4</p> 	<p>Pos. 15 Bolt 8,8 B M8x45mm</p> <p>PCS.: 1</p> 
<p>Pos. 4 Right bracket</p> <p>PCS.: 1</p> 	<p>Pos. 10 Nut 8 B M12</p> <p>PCS.: 6</p> 	<p>Pos. 16 Plain washer Ø8mm</p> <p>PCS.: 2</p> 
<p>Pos. 5 Left bracket</p> <p>PCS.: 1</p> 	<p>Pos. 11 Plain washer Ø13mm</p> <p>PCS.: 6</p> 	<p>Pos. 17 Nut 8 B M8</p> <p>PCS.: 1</p> 

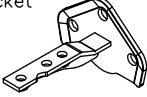

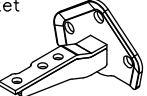
## PPUH AUTO-HAK Sp.J.

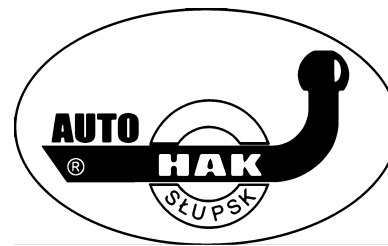
Produkcja Zaczepów Kulowych  
Henryk & Zbigniew Nejman  
76-200 SŁUPSK ul. Słoneczna 16K  
tel/fax (059) 8-414-414; 8-414-413  
E-mail: [office@autohak.com.pl](mailto:office@autohak.com.pl)  
[www.autohak.com.pl](http://www.autohak.com.pl)

### Towing hitch (without electrical set)

Class: **A50-X** Cat. no. **B08A**

Designed for:

Manufacturer: **BMW**

Model: **SERIES 5 (E39)**

Type: **4 door**

produced since 12.1995 till 2001  
and since 2002 till 10.2003

Technical data:

**D-value: 10,3 kN**

maximum trailer weight: **2100 kg**

maximum vertical cup load: **90 kg**

**Approval number according to Directive 94/20/EC: e20\*94/20\*0792\*00**

### Foreword

This towing hitch is designed according to rules of safety traffic regulations. The towing hitch is a safety component and can be installed only by qualified personnel. Any alteration or conversion of the towing hitch is prohibited and would lead to cancellation of design certification. Remove insulating compound and underseal from vehicle (if present) in the area of the mating surfaces of the towing hitch.

The vehicle manufacturer's specifications regarding trailer load and max. vertical cup load are decisive for driving, and values for the towing hitch cannot be exceeded.

*D-value formula:*

$$\frac{\text{Max trailer weight [kg]} \times \text{Max vehicle weight [kg]}}{\text{Max trailer weight [kg]} + \text{Max vehicle weight [kg]}} \times \frac{9,81}{1000} = D \text{ [kN]}$$

## FITTING INSTRUCTION

Clamp mark in acc. with		Cables joining
ISO	PN	
1	L	Left directional lights
2	+	Rear fog lights
3	31	Ground
4	R	Right directional lights
5	58R	Right side parking lights
6	54	Stoptlights
7	58L	Left side parking lights

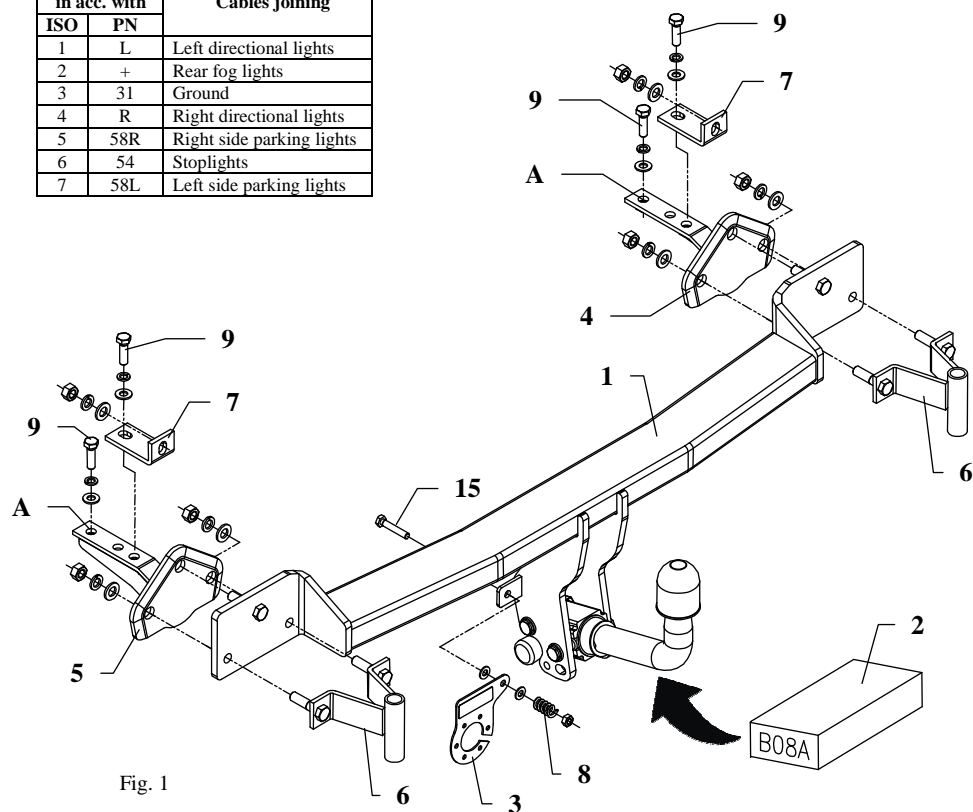

Fig. 1

The towing hitch is designed to fit in following car: **BMW 5 series E39, 4 door**, produced since 12.1995 till 2001 and produced since 2002 till 10.2003, catalogue no. **B08A** and is prepared to tow trailers max trailers weight **2100 kg** and max vertical load **90 kg**.

### *From manufacturer*

Thank you for buying our product. Their reliability has been confirmed in many tests. Reliability of towing hitch depends also on correct assembly and right operation. For this reasons we kindly ask to read carefully this instruction and apply to hints.

*The towing hitch should be install in points described by a car producer.*

## The instruction of the assembly

1. Disassemble the bumper. Disassemble aluminium element and muffler from the bumper (this part will be not use any more).
2. In aluminium and plastic part of the bumper cut out fragments (as shown on the fig. 2 and 3).
3. In baggage part of the car disassemble covers (rear part and bottom).
4. Insert brackets (pos. 4 and 5) to chassis members (as shown on the fig. 1) and fix loosely through holes (pos. A) using bolts M10x35mm (pos. 9).
5. Fix handles (pos. 6) to the aluminium part of the bumper and next fix its plastic part.
6. So prepared towing hitch put to the rear part of car, put side brackets and angle bars (pos. 7) and fix.
7. Fix body of the automat according to supplied instruction.
8. Fix the socket plate (pos. 3) as shown on the drawing.
9. Tighten all bolts according to the torque shown in the table.
10. Connect electric wires of 7-poles socket according to the instruction of the car. (Recommend to make at authorized service station).
11. Complete paint layer damaged during installation.

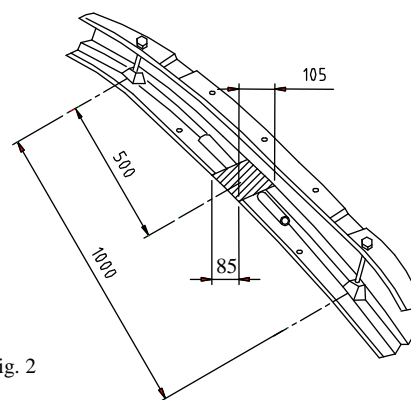

Fig. 2

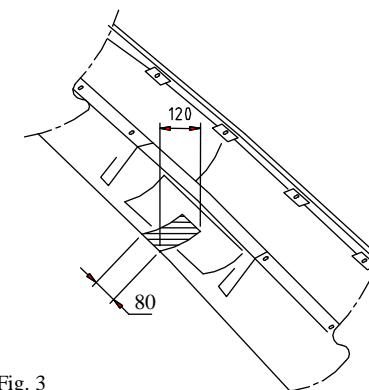

Fig. 3

### Torque settings for nuts and bolts (8,8):

<b>M6</b> - 11 Nm	<b>M8</b> - 25 Nm	<b>M10</b> - 50 Nm
<b>M12</b> - 87 Nm	<b>M14</b> - 138 Nm	<b>M16</b> - 210 Nm

### NOTE

After install the towing hitch you should get adequate note in registration book (at authorised service station).The car should be equipped with:

- Indicators
- Tow mirrors

After 1000km of exploitation check all bolts and nuts. The ball of towing hitch must be always kept clear and conserve with a grease.